

## 阅读申明

- 1.本站收集的数据手册和产品资料都来自互联网，版权归原作者所有。如读者和版权方有任何异议请及时告之，我们将妥善解决。
- 2.本站提供的中文数据手册是英文数据手册的中文翻译，其目的是协助用户阅读，该译文无法自动跟随原稿更新，同时也可能存在翻译上的不当。建议读者以英文原稿为参考以便获得更精准的信息。
- 3.本站提供的产品资料，来自厂商的技术支持或者使用者的心得体会等，其内容可能存在描述上的差异，建议读者做出适当判断。
- 4.如需与我们联系，请发邮件到marketing@iczoom.com，主题请标有“数据手册”字样。

## Read Statement

1. The datasheets and other product information on the site are all from network reference or other public materials, and the copyright belongs to the original author and original published source. If readers and copyright owners have any objections, please contact us and we will deal with it in a timely manner.
2. The Chinese datasheets provided on the website is a Chinese translation of the English datasheets. Its purpose is for reader's learning exchange only and do not involve commercial purposes. The translation cannot be automatically updated with the original manuscript, and there may also be improper translations. Readers are advised to use the English manuscript as a reference for more accurate information.
3. All product information provided on the website refer to solutions from manufacturers' technical support or users the contents may have differences in description, and readers are advised to take the original article as the standard.
4. If you have any questions, please contact us at marketing@iczoom.com and mark the subject with "Datasheets" .

# SCAN16512

## Low Voltage Universal 16-bit IEEE 1149.1 Bus Transceiver with TRI-STATE Outputs

### General Description

The SCAN16512 is a high speed, low-power universal bus transceiver featuring data inputs organized into two 8-bit bytes with output enable and latch enable control signals. This function is configurable as a D-type Latch or Flip-Flop, and can operate in transparent, latched, or clocked mode. This device is compliant with IEEE 1149.1 Standard Test Access Port and Boundary Scan Architecture with the incorporation of the defined boundary-scan test logic and test access port consisting of Test Data Input (TDI), Test Data Out (TDO), Test Mode Select (TMS), Test Clock (TCK), and Test Reset (TRST).

### Features

- IEEE 1149.1 (JTAG) Compliant
- 2.7V to 3.6V  $V_{CC}$  Operation
- TRI-STATE outputs for bus-oriented applications
- Dual byte-wide data for bus applications
- Power down high Impedance inputs and outputs
- Optional Bus Hold on data inputs eliminates the need for external pullup/pulldown resistors (SCANH16512, SCANH162512 versions)
- Optional  $25\Omega$  series resistors in outputs to minimize noise and eliminate termination resistors (SCAN162512, SCANH162512 versions)
- Supports live insertion/withdrawal
- Includes CLAMP and HIGHZ instructions

### Block Diagram

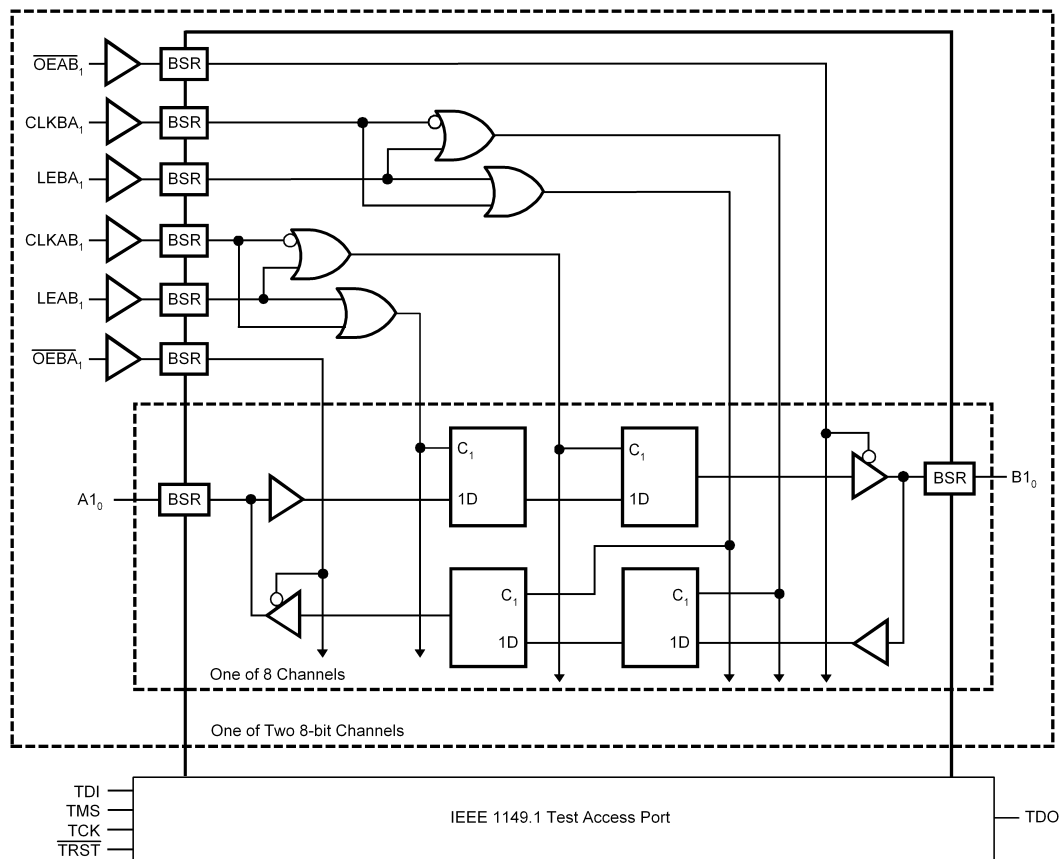

20026602

## Pin Descriptions

Pin Name	Description
A1 <sub>0</sub> -A1 <sub>7</sub> , A2 <sub>0</sub> -A2 <sub>7</sub>	Normal-function A-bus I/O ports. See function table for normal-mode logic.
B1 <sub>0</sub> -B1 <sub>7</sub> , B2 <sub>0</sub> -B2 <sub>7</sub>	Normal-function B-bus I/O ports. See function table for normal-mode logic.
CLKAB <sub>1</sub> , CLKBA <sub>1</sub> , CLKAB <sub>2</sub> , CLKBA <sub>2</sub>	Normal-function clock inputs. See function table for normal-mode logic.
GND	Ground
V <sub>CC</sub>	Supply Voltage
LEAB <sub>1</sub> , LEBA <sub>1</sub> , LEAB <sub>2</sub> , LEBA <sub>2</sub>	Normal-function latch enables. See function table for normal-mode logic.
$\overline{\text{OEAB}}_1$ , $\overline{\text{OEBA}}_1$ , $\overline{\text{OEAB}}_2$ , $\overline{\text{OEBA}}_2$	Normal-function output enables. See function table for normal-mode logic.
TDO	The Test Data Output to support IEEE Std 1149.1-1990. TDO is the serial output for shifting data through the instruction register or selected data register.
TMS	The Test Mode Select input to support IEEE Std 1149.1-1990. TMS directs the device through its TAP controller states. An internal pull-up forces TMS high if left unconnected.
TCK	The Test Clock input to support IEEE Std 1149.1-1990. Test operations of the device are synchronous to TCK. Data is captured on the rising edge of TCK and outputs change on the falling edge of TCK.
TDI	The Test Data Input to support IEEE Std 1149.1-1990. TDI is the serial input to shift data through the instruction register or the selected data register. An internal pull-up resistor forces TDI high if left unconnected.
$\overline{\text{TRST}}$	The Test Reset Input to support IEEE Std 1149.1-1990. TRST is the asynchronous reset pin which will force the TAP controller to its initialization state when active. An internal pullup resistor forces $\overline{\text{TRST}}$ high if left unconnected.

## BGA Pinout

	1	2	3	4	5	6	7	8
A	A1 <sub>0</sub>	A1 <sub>2</sub>	A1 <sub>4</sub>	A1 <sub>6</sub>	A2 <sub>0</sub>	A2 <sub>2</sub>	A2 <sub>4</sub>	A2 <sub>6</sub>
B	A1 <sub>1</sub>	A1 <sub>3</sub>	A1 <sub>5</sub>	A1 <sub>7</sub>	A2 <sub>1</sub>	A2 <sub>3</sub>	A2 <sub>5</sub>	A2 <sub>7</sub>
C	$\overline{\text{TRST}}$	CLKAB <sub>1</sub>	LEAB <sub>1</sub>	$\overline{\text{OEAB}}_1$	GND	CLKAB <sub>2</sub>	LEAB <sub>2</sub>	$\overline{\text{OEAB}}_2$
D	TMS	GND	V <sub>CC</sub>	GND	V <sub>CC</sub>	GND	TDI	TDO
E	TCK	GND	V <sub>CC</sub>	V <sub>CC</sub>	GND	GND	N/C	V <sub>CC</sub>
F	CLKBA <sub>1</sub>	LEBA <sub>1</sub>	$\overline{\text{OEBA}}_1$	GND	N/C	CLKBA <sub>2</sub>	LEBA <sub>2</sub>	$\overline{\text{OEBA}}_2$
G	B1 <sub>1</sub>	B1 <sub>3</sub>	B1 <sub>5</sub>	B1 <sub>7</sub>	B2 <sub>1</sub>	B2 <sub>3</sub>	B2 <sub>5</sub>	B2 <sub>7</sub>
H	B1 <sub>0</sub>	B1 <sub>2</sub>	B1 <sub>4</sub>	B1 <sub>6</sub>	B2 <sub>0</sub>	B2 <sub>2</sub>	B2 <sub>4</sub>	B2 <sub>6</sub>

## Connection Diagram

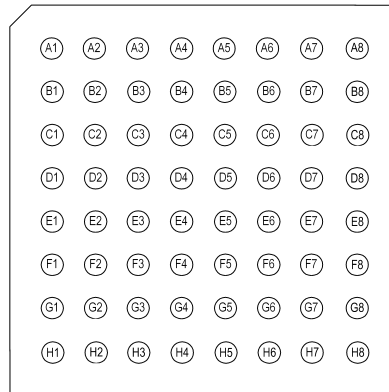

20026603

**Top View**  
See NS Package Number SLC64A

## Truth Table

**Function Table (Note 1)**

Inputs				Outputs
$\overline{OEAB}$	LEAB	CLKAB	A	B
L	L	L	X	$B_0$ (Note 2)
L	L	↑	L	L
L	L	↑	H	H
L	H	X	L	L
L	H	X	H	H
H	X	X	X	Z

H = HIGH Voltage Level

L = LOW Voltage Level

X = Immaterial (HIGH or LOW, inputs may not float)

Z = High Impedance

**Note 1:** A-to-B data flow is shown. B-to-A data flow is similar, but uses  $\overline{OEBA}$ , LEBA, and CLKBA.

**Note 2:** Output level before the indicated steady-state input conditions were established.

## Functional Description

In the normal mode, these devices are 16-bit universal bus transceivers that combine D-type latches and D-type flip-flops to allow data flow in transparent, latched, or clocked modes. They can be used as two 8-bit transceivers, or as one 16-bit transceiver. The test circuitry can be activated by the TAP to take snapshot samples of the data appearing at the device pins or to perform a self test on the boundary-test cells. Activating the TAP may affect the normal functional operation of the universal bus transceivers. When the TAP is activated, the test circuitry performs boundary-scan test operations according to the protocol described in IEEE Std 1149.1-1990.

Data flow in each direction is controlled by output-enable ( $\overline{OEAB}$  and  $\overline{OEBA}$ ), latch-enable (LEAB and LEBA), and clock (CLKAB and CLKBA) inputs. For A-to-B data flow, the

devices operate in the transparent mode when LEAB is high. When LEAB is low, the A data is latched while CLKAB is held at a static low or high logic level. Otherwise, if LEAB is low, A data is stored on a low-to-high transition of CLKAB. When  $\overline{OEAB}$  is LOW, the B outputs are active. When  $\overline{OEAB}$  is HIGH, the B outputs are in the high-impedance state. B-to-A data flow is similar to A-to-B data flow but uses the  $\overline{OEBA}$ , LEBA, and CLKBA inputs.

Five dedicated test pins are used to observe and control the operation of the test circuitry: test data input (TDI), test data output (TDO), test mode select (TMS), test clock (TCK), and test reset ( $\overline{TRST}$ ). All testing and scan operations are synchronized to the TAP interface.

For details about the sequence of boundary scan cells in the SCAN16512, please refer to the BSDL (Boundary Scan Description Language) file available on our website.

**Absolute Maximum Ratings** (Note 3)

Supply Voltage ( $V_{CC}$ )	-0.5V to +4.6V
DC Input Diode Current ( $I_{IK}$ )	
$V_I = -0.5V$	-50 mA
DC Output Diode Current ( $I_{OK}$ )	
$V_O = -0.5V$	-50 mA
DC Input Voltage ( $V_I$ )	-0.5V to 4.6V
DC Output Voltage ( $V_O$ )	-0.5V to 4.6V
DC Output Source/Sink Current ( $I_O$ )	$\pm 50$ mA
DC $V_{CC}$ or Ground Current	
Per Supply Pin	$\pm 100$ mA
Junction Temperature	+150°C
Storage Temperature	-65°C to +150°C
Lead Temperature (Solder, 4sec)	
64L BGA	220 °C
Thermal Resistance	
BGA $\theta_{JA}$	62°C/W

Package Derating

16.1mW/°C above  
25°C

ESD (Min)

1000V

**Recommended Operating Conditions**Supply Voltage ( $V_{CC}$ )

SCAN16512

2.7V to 3.6V

Input Voltage ( $V_I$ )

0V to 3.6V

Output Voltage ( $V_O$ )

0V to 3.6V

Operating Temperature ( $T_A$ )

Industrial

-40°C to +85°C

**Note 3:** Absolute maximum ratings are those values beyond which damage to the device may occur. The databook specifications should be met, without exception, to ensure that the system design is reliable over its power supply, temperature, and output/input loading variables. National does not recommend operation of SCAN circuits outside databook specifications.

**DC Electrical Characteristics**

Symbol	Parameter	$V_{CC}$ (V)	Industrial		Units	Conditions	
			$T_A = -40^\circ\text{C to } +85^\circ\text{C}$				
			Min	Max			
$V_{IH}$	Minimum High Input Voltage	2.7	2.0		V	$V_{OUT} = 0.1V$ or $V_{CC} - 0.1V$	
		3.6	2.0				
$V_{IL}$	Maximum Low Input Voltage	2.7		0.8	V	$V_{OUT} = 0.1V$ or $V_{CC} - 0.1V$	
		3.6		0.8			
$V_{OH}$	Minimum High Output Voltage All Outputs, All Options	2.7	2.5		V	$I_{OUT} = -100 \mu A$	
		3.6	3.4				
	Minimum High Output Voltage TDO Outputs, All Options	2.7	2.2		V	$V_{IN} = V_{IL}$ or $V_{IH}$ , $I_{OH} = -12mA$	
		3.0	2.2				
	Minimum High Output Voltage A and B Ports: SCAN16512 and SCANH16512 options	2.7	2.2		V	$V_{IN} = V_{IL}$ or $V_{IH}$ , $I_{OH} = -12mA$	
		3.0	2.2				
	Minimum High Output Voltage A and B Ports: SCAN162512 and SCANH162512 options (25 $\Omega$ series resistor options)	2.7	2.2		V	$V_{IN} = V_{IL}$ or $V_{IH}$ , $I_{OH} = -4mA$	
		3.0	2.2				
	$V_{OL}$	Maximum Low Output Voltage All Outputs, All Options	2.7		0.2	V	$I_{OUT} = 100 \mu A$
			3.6		0.2		
Maximum Low Output Voltage TDO Outputs, All Options		2.7		0.4	V	$V_{IN} = V_{IL}$ or $V_{IH}$ , $I_{OL} = 12mA$	
		3.0		0.55			
Maximum Low Output Voltage A and B Ports: SCAN16512 and SCANH16512 Options		2.7		0.4	V	$V_{IN} = V_{IL}$ or $V_{IH}$ , $I_{OL} = 12mA$	
		3.0		0.55			
						$V_{IN} = V_{IL}$ or $V_{IH}$ , $I_{OL} = 24mA$	

**DC Electrical Characteristics** (Continued)

Symbol	Parameter	V <sub>CC</sub> (V)	Industrial		Units	Conditions
			T <sub>A</sub> = -40°C to +85°C			
			Min	Max		
	Maximum Low Output Voltage A and B Ports: SCAN162512 and SCANH162512 Options (25Ω series resistor options)	2.7		0.4	V	V <sub>IN</sub> = V <sub>IL</sub> or V <sub>IH</sub> , I <sub>OL</sub> = 4mA
		3.0		0.6	V	V <sub>IN</sub> = V <sub>IL</sub> or V <sub>IH</sub> , I <sub>OL</sub> = 12mA
I <sub>IN</sub>	Maximum Input Leakage Current	3.6		±5.0	μA	V <sub>I</sub> = V <sub>CC</sub> , GND
I <sub>ILR</sub>	Input Low Current	3.6		-200	μA	V <sub>IN</sub> = GND
I <sub>OZ</sub>	Maximum I/O Leakage Current	3.6		±5.0	μA	V <sub>I</sub> (OE) = V <sub>IL</sub> , V <sub>IH</sub> V <sub>I</sub> = V <sub>CC</sub> , GND V <sub>O</sub> = V <sub>CC</sub> , GND
I <sub>I(HOLD)</sub>	Bus Hold Input Minimum Drive Hold Current (Note 4)	2.7	±75		μA	V <sub>I</sub> = 0.8V or 2.0V
		3.6		±625		V <sub>I</sub> = 0 to 3.6V
V <sub>IKL</sub>	Input Clamp Diode Voltage	2.7		-1.5	V	I <sub>IN</sub> = -18mA
I <sub>OFF</sub>	Power-off Leakage Current	0.0		±10.0	μA	V <sub>O</sub> = V <sub>CC</sub> , GND
I <sub>CC</sub>	Maximum Quiescent Supply Current	3.6		20	μA	
I <sub>CCt</sub>	Maximum I <sub>CC</sub> Per Input	3.6		0.5	mA	V <sub>I</sub> = V <sub>CC</sub> -0.6V

**Note 4:** Applies to devices with Bus Hold feature only.

**Noise Specifications**

Applies to SCAN16512 and SCANH16512 options, C<sub>L</sub> = 30pF, R<sub>L</sub> = 500Ω to GND

Symbol	Parameter	V <sub>CC</sub> (V)	Industrial	Units
			T <sub>A</sub> = 25°C	
			Typical Limits	
V <sub>OLP</sub>	Quiet Output Maximum Dynamic VOL (Note 5)	3.3	1.2	V
V <sub>OLV</sub>	Quiet Output Minimum Dynamic VOL (Note 5)	3.3	-1.5	V
V <sub>OHP</sub>	Quiet Output Maximum Dynamic VOH (Note 6)	3.3	VOH + 0.9	V
V <sub>OHV</sub>	Quiet Output Minimum Dynamic VOH (Note 6)	3.3	VOH - 1.5	V

## Noise Specifications

Applies to SCAN162512 and SCANH162512 options,  $C_L = 30\text{pF}$ ,  $R_L = 500\Omega$  to GND

Symbol	Parameter	$V_{CC}$ (V)	Industrial	Units
			$T_A = 25^\circ\text{C}$	
			Typical Limits	
$V_{OLP}$	Quiet Output Maximum Dynamic VOL (Note 5)	3.3	0.6	V
$V_{OLV}$	Quiet Output Minimum Dynamic VOL (Note 5)	3.3	-0.5	V
$V_{OHP}$	Quiet Output Maximum Dynamic VOH (Note 6)	3.3	$VOH + 0.5$	V
$V_{OHV}$	Quiet Output Minimum Dynamic VOH (Note 6)	3.3	$VOH - 0.6$	V

**Note 5:** Maximum number of outputs is defined as n. (n-1) outputs are switched LOW while the quiet output is monitored in a LOW (VOL) state. Also, (n-1) outputs are switched HIGH while the quiet output is monitored in a LOW (VOL) state.

**Note 6:** Maximum number of outputs is defined as n. (n-1) outputs are switched LOW while the quiet output is monitored in a HIGH (VOH) state. Also, (n-1) outputs are switched HIGH while the quiet output is monitored in a HIGH (VOH) state.

## AC Electrical Characteristics

Normal Operation, over recommended operating supply voltage and temperature ranges unless otherwise specified.

Symbol	Parameter	SCAN16512, SCANH16512		Units
		$C_L = 30\text{ pF}$ $R_L = 500\Omega$ to GND		
		Min	Max	
$t_{PLH}$ , $t_{PHL}$	Propagation Delay A to B, B to A		5.5	ns
$t_{PLH}$ , $t_{PHL}$	Propagation Delay CLKAB to B, CLKBA to A		6.0	ns
$t_{PLH}$ , $t_{PHL}$	Propagation Delay LEAB to B, LEBA to A		6.0	ns
$t_{PLZ}$ , $t_{PHZ}$	Disable Time, $\overline{OEAB}$ to B, $\overline{OEBA}$ to A		7.5	ns
$t_{PZL}$ , $t_{PZH}$	Enable Time, $\overline{OEAB}$ to B, $\overline{OEBA}$ to A		7.5	ns

## AC Electrical Characteristics

Normal Operation, over recommended operating supply voltage and temperature ranges unless otherwise specified.

Symbol	Parameter	SCAN162512		Units
		$C_L = 30\text{ pF}$ $R_L = 500\Omega$ to GND		
		Min	Max	
$t_{PLH}$ , $t_{PHL}$	Propagation Delay A to B, B to A		6.0	ns
$t_{PLH}$ , $t_{PHL}$	Propagation Delay CLKAB to B, CLKBA to A		6.5	ns
$t_{PLH}$ , $t_{PHL}$	Propagation Delay LEAB to B, LEBA to A		6.5	ns
$t_{PLZ}$ , $t_{PHZ}$	Disable Time, $\overline{OEAB}$ to B, $\overline{OEBA}$ to A		7.5	ns
$t_{PZL}$ , $t_{PZH}$	Enable Time, $\overline{OEAB}$ to B, $\overline{OEBA}$ to A		7.5	ns

## AC Electrical Characteristics

Normal Operation, over recommended operating supply voltage and temperature ranges unless otherwise specified.

Symbol	Parameter	SCANH162512		Units
		$C_L = 30 \text{ pF}$ $R_L = 500\Omega \text{ to GND}$		
		Min	Max	
$t_{PLH}$ , $t_{PHL}$	Propagation Delay A to B, B to A		6.0	ns
$t_{PLH}$ , $t_{PHL}$	Propagation Delay CLKAB to B, CLKBA to A		6.5	ns
$t_{PLH}$ , $t_{PHL}$	Propagation Delay LEAB to B, LEBA to A		6.5	ns
$t_{PLZ}$ , $t_{PHZ}$	Disable Time, $\overline{OEAB}$ to B, $\overline{OEBA}$ to A		7.5	ns
$t_{PZL}$ , $t_{PZH}$	Enable Time, $\overline{OEAB}$ to B, $\overline{OEBA}$ to A		8.0	ns

## AC Operating Requirements

Normal Operation, over recommended operating supply voltage and temperature ranges unless otherwise specified

Symbol	Parameter	All Options	Units
		$T_A = -40^\circ\text{C to } +85^\circ\text{C}$ $C_L = 30 \text{ pF}$ , $R_L = 500\Omega \text{ to GND}$	
		Guaranteed Minimum	
$t_S$	Setup Time, A to CLKAB or B to CLKBA	1.5	ns
$t_H$	Hold Time, A to CLKAB or B to CLKBA	2.0	ns
$t_S$	Setup Time, A to LEAB or B to LEBA	1.5	ns
$t_H$	Hold Time, A to LEAB or B to LEBA	2.5	ns
$t_W$	Pulse Width, CLKAB or CLKBA, high or low	2.0	ns
$t_W$	Pulse Width, LEAB or LEBA high	2.0	ns
$f_{max}$	Maximum CLKAB or CLKBA Clock Frequency	250	MHz

## AC Operating Requirements

can Test Operation, over recommended operating supply voltage and temperature ranges unless otherwise specified

Symbol	Parameter	All Options	Units
		$T_A = -40^\circ\text{C to } +85^\circ\text{C}$ $C_L = 30 \text{ pF}$ , $R_L = 500\Omega \text{ to GND}$	
		Guaranteed Minimum	
$t_S$	Setup Time, H or L, TMS to TCK	2.0	ns
$t_H$	Hold Time, H or L, TCK to TMS	1.0	ns
$t_S$	Setup Time, H or L, TDI to TCK	1.0	ns
$t_H$	Hold Time, H or L, TCK to TDI	2.0	ns
$t_W$	Pulse Width TCK High or Low	10	ns
$t_W$	Pulse Width $\overline{TRST}$ , Low	2.5	ns
$f_{max}$	Maximum TCK Clock Frequency	25	MHz
$t_{REC}$	Recovery Time, $\overline{TRST}$ to TCK	2.0	ns



# AC Loading and Waveforms

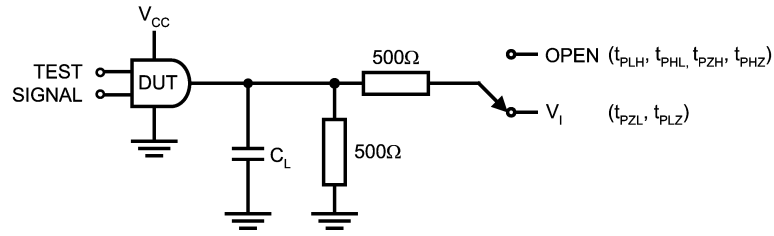

20026614

FIGURE 1. AC Test Circuit ( $C_L$  includes probe and jig capacitance)

$V_I$	$C_L$
$V_{CC} * 2$	30pF

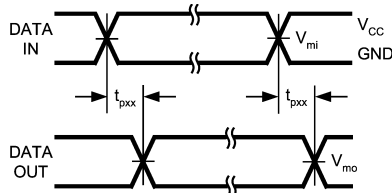

20026610

Waveform for Inverting and Non-inverting Functions

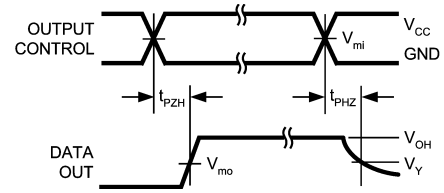

20026611

Tristate Output High Enable and Disable Times for Logic

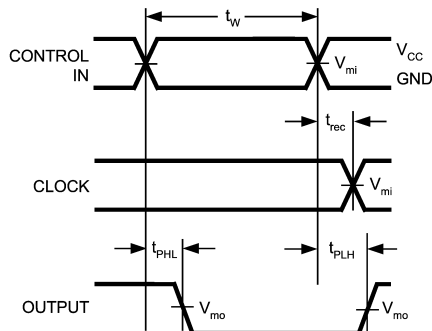

20026612

Propagation Delay, Pulse Width and  $t_{REC}$  Waveforms

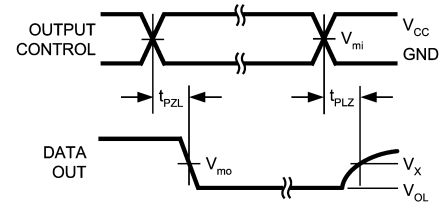

20026613

Tristate Output Low Enable and Disable Times for Logic

FIGURE 2. Timing Waveforms  
(Input Characteristics;  $f = 1\text{MHz}$ ,  $t_r = t_f = 2.5\text{ns}$ )

Symbol	$V_{CC}$
	2.7 - 3.6V
$V_{mi}$	1.5V
$V_{mo}$	1.5V
$V_x$	$V_{OL} + 0.3V$
$V_y$	$V_{OH} - 0.3V$

## Capacitance and I/O Characteristics

Refer to National's website for IBIS models at <http://www.national.com/scan>

### Device ID Register

Ordering Code	Features	Device ID	Manufacturer & LSB
SCAN16512SM	No bus hold, no series resistor	FC30	01F
SCANH16512SM	With bus hold only	FC31	01F
SCAN162512SM	With 25 $\Omega$ series resistors in outputs	FC32	01F
SCANH162512SM	With 25 $\Omega$ series resistors and bus hold	FC33	01F

## Physical Dimensions inches (millimeters)

unless otherwise noted

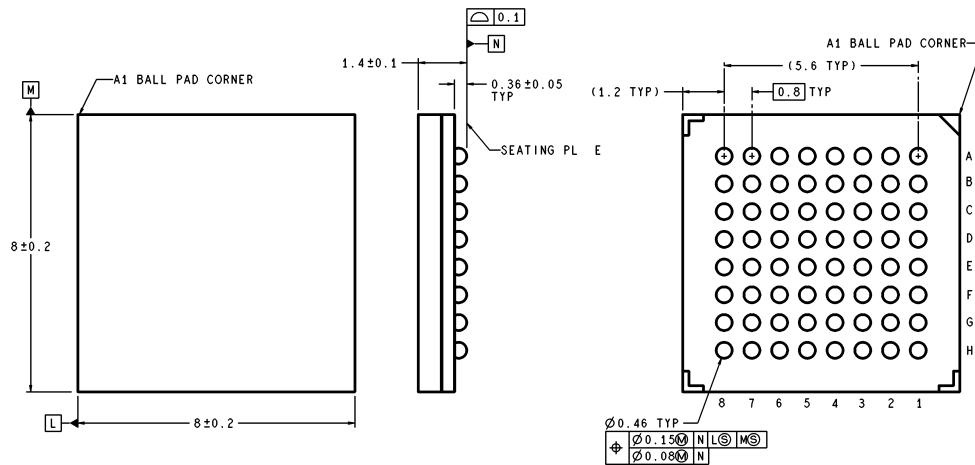

DIMENSIONS ARE IN MILLIMETERS

SLC64A (Rev B)

**64-Lead Ball Grid Array Package**  
**Order Number SCAN16512SM,**  
**SCANH16512SM, SCAN162512SM, SCANH162512SM**  
**NS Package Number SLC64A**

### LIFE SUPPORT POLICY

NATIONAL'S PRODUCTS ARE NOT AUTHORIZED FOR USE AS CRITICAL COMPONENTS IN LIFE SUPPORT DEVICES OR SYSTEMS WITHOUT THE EXPRESS WRITTEN APPROVAL OF THE PRESIDENT AND GENERAL COUNSEL OF NATIONAL SEMICONDUCTOR CORPORATION. As used herein:

1. Life support devices or systems are devices or systems which, (a) are intended for surgical implant into the body, or (b) support or sustain life, and whose failure to perform when properly used in accordance with instructions for use provided in the labeling, can be reasonably expected to result in a significant injury to the user.
2. A critical component is any component of a life support device or system whose failure to perform can be reasonably expected to cause the failure of the life support device or system, or to affect its safety or effectiveness.



**National Semiconductor Corporation**  
Americas  
Email: support@nsc.com

www.national.com

**National Semiconductor Europe**  
Fax: +49 (0) 180-530 85 86  
Email: europe.support@nsc.com  
Deutsch Tel: +49 (0) 69 9508 6208  
English Tel: +44 (0) 870 24 0 2171  
Français Tel: +33 (0) 1 41 91 8790

**National Semiconductor Asia Pacific Customer Response Group**  
Tel: 65-2544466  
Fax: 65-2504466  
Email: ap.support@nsc.com

**National Semiconductor Japan Ltd.**  
Tel: 81-3-5639-7560  
Fax: 81-3-5639-7507