

阅读申明

- 1.本站收集的数据手册和产品资料都来自互联网，版权归原作者所有。如读者和版权方有任何异议请及时告之，我们将妥善解决。
- 2.本站提供的中文数据手册是英文数据手册的中文翻译，其目的是协助用户阅读，该译文无法自动跟随原稿更新，同时也可能存在翻译上的不当。建议读者以英文原稿为参考以便获得更精准的信息。
- 3.本站提供的产品资料，来自厂商的技术支持或者使用者的心得体会等，其内容可能存在描述上的差异，建议读者做出适当判断。
- 4.如需与我们联系，请发邮件到marketing@iczoom.com，主题请标有“数据手册”字样。

Read Statement

1. The datasheets and other product information on the site are all from network reference or other public materials, and the copyright belongs to the original author and original published source. If readers and copyright owners have any objections, please contact us and we will deal with it in a timely manner.
2. The Chinese datasheets provided on the website is a Chinese translation of the English datasheets. Its purpose is for reader's learning exchange only and do not involve commercial purposes. The translation cannot be automatically updated with the original manuscript, and there may also be improper translations. Readers are advised to use the English manuscript as a reference for more accurate information.
3. All product information provided on the website refer to solutions from manufacturers' technical support or users the contents may have differences in description, and readers are advised to take the original article as the standard.
4. If you have any questions, please contact us at marketing@iczoom.com and mark the subject with "Datasheets" .

DATA SHEET

TEA1533P; TEA1533AP **GreenChip™II SMPS control IC**

Product specification
Supersedes data of 2002 May 31

2002 Aug 23

GreenChip™II SMPS control IC

TEA1533P; TEA1533AP

FEATURES

Distinctive features

- Universal mains supply operation (70 to 276 V AC)
- High level of integration, giving a very low external component count.

Green features

- Valley or zero voltage switching for minimum switching losses
- Efficient quasi-resonant operation at high power levels
- Frequency reduction at low power standby for improved system efficiency (<3 W)
- Cycle skipping mode at very low loads. $P_i < 300$ mW at no-load operation for a typical adapter application
- On-chip start-up current source.

Protection features

- Safe restart mode for system fault conditions
- Continuous mode protection by means of demagnetization detection (zero switch-on current)
- Accurate and adjustable overvoltage protection (latched in TEA1533P, safe restart in TEA1533AP)
- Short winding protection
- Undervoltage protection (foldback during overload)
- Overtemperature protection (latched in TEA1533P, safe restart in TEA1533AP)
- Low and adjustable overcurrent protection trip level
- Soft (re)start
- Mains voltage-dependent operation enabling level.

APPLICATIONS

Besides typical application areas, i.e. adapters and chargers, the device can be used in TV and monitor supplies and all applications that demand an efficient and cost-effective solution up to 250 W.

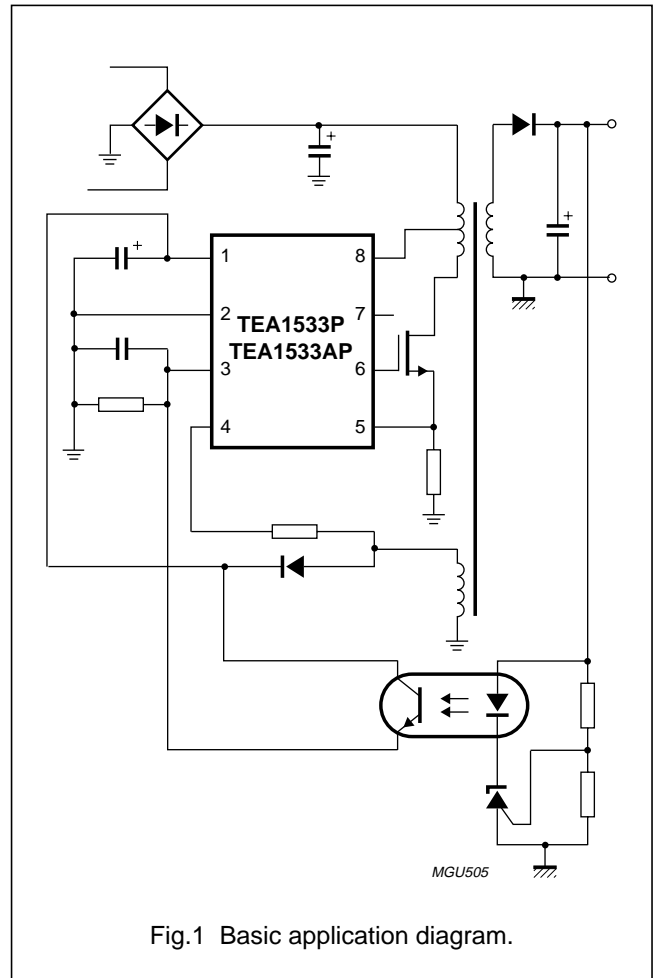

Fig.1 Basic application diagram.

GreenChip™II SMPS control IC

TEA1533P; TEA1533AP

GENERAL DESCRIPTION

The GreenChip™(1)II is the second generation of green Switched Mode Power Supply (SMPS) control ICs operating directly from the rectified universal mains. A high level of integration leads to a cost effective power supply with a very low number of external components.

The special built-in green functions allow the efficiency to be optimum at all power levels. This holds for quasi-resonant operation at high power levels, as well as fixed frequency operation with valley switching at medium power levels. At low power (standby) levels, the system operates at a reduced frequency and with valley detection.

The proprietary high voltage BCD800 process makes direct start-up possible from the rectified mains voltage in an effective and green way. A second low voltage BICMOS IC is used for accurate, high-speed protection functions and control.

Highly efficient and reliable supplies can easily be designed using the GreenChipII control IC.

(1) GreenChip is a trademark of Koninklijke Philips Electronics N.V.

ORDERING INFORMATION

TYPE NUMBER	PACKAGE		
	NAME	DESCRIPTION	VERSION
TEA1533P	DIP8	plastic dual in-line package; 8 leads (300 mil)	SOT97-1
TEA1533AP			

GreenChip™ II SMPS control IC

TEA1533P; TEA1533AP

BLOCK DIAGRAM

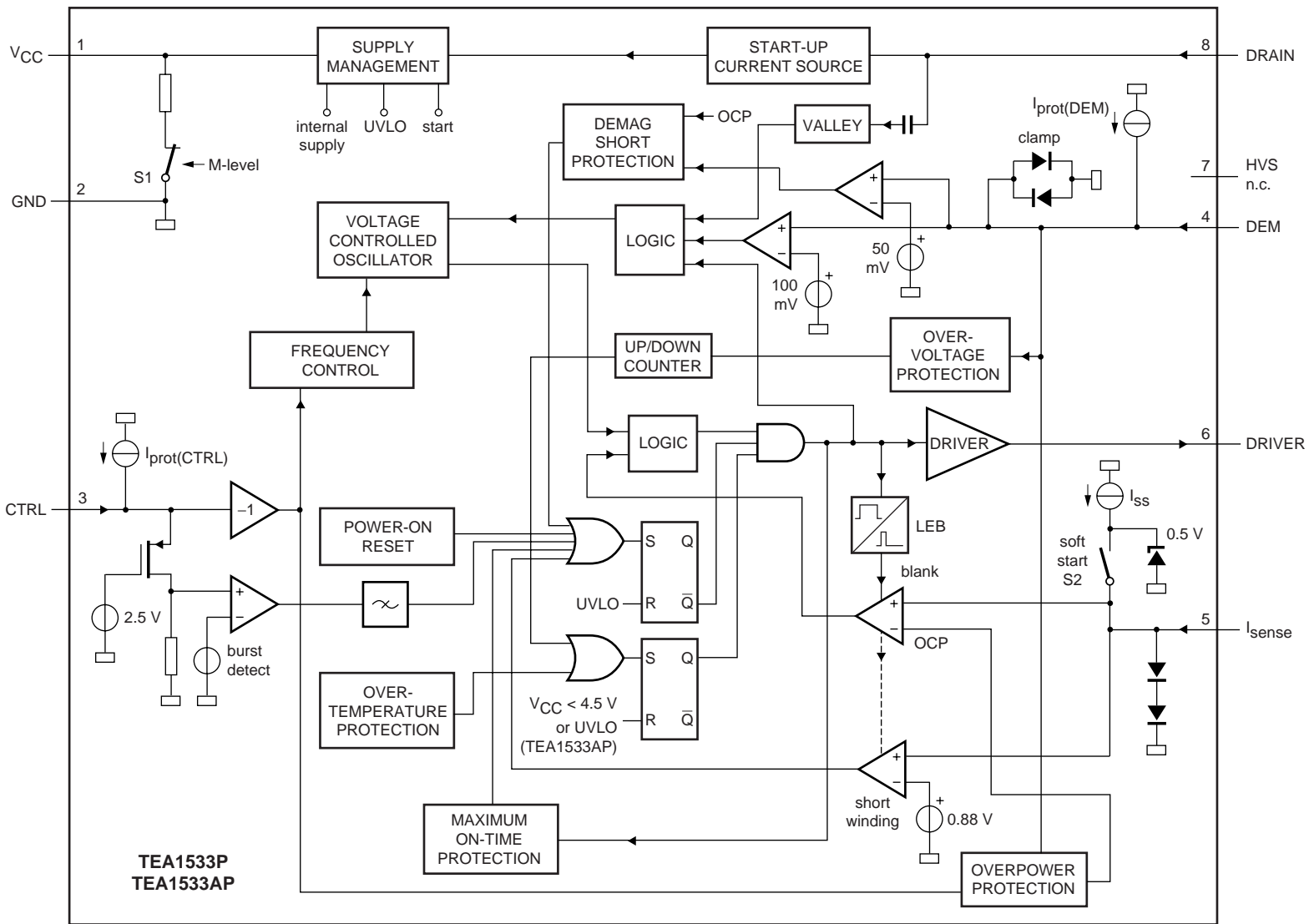

MGU506

Fig.2 Block diagram.

GreenChip™II SMPS control IC

TEA1533P; TEA1533AP

PINNING

SYMBOL	PIN	DESCRIPTION
V _{CC}	1	supply voltage
GND	2	ground
CTRL	3	control input
DEM	4	input from auxiliary winding for demagnetization timing, overvoltage and overpower protection
I _{sense}	5	programmable current sense input
DRIVER	6	gate driver output
HVS	7	high voltage safety spacer, not connected
DRAIN	8	drain of external MOS switch, input for start-up current and valley sensing

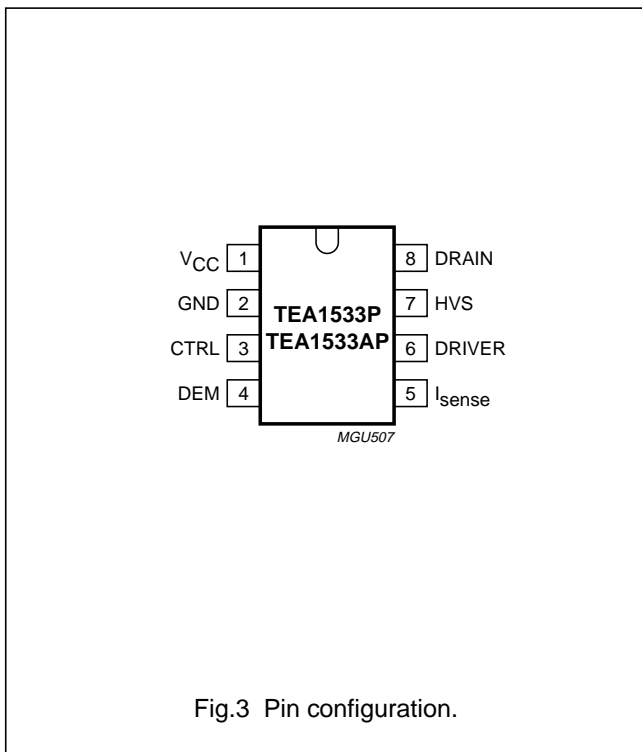

Fig.3 Pin configuration.

FUNCTIONAL DESCRIPTION

The TEA1533 is the controller of a compact flyback converter, and is situated at the primary side. An auxiliary winding of the transformer provides demagnetization detection and powers the IC after start-up.

The TEA1533 can operate in multi modes (see Fig.4).

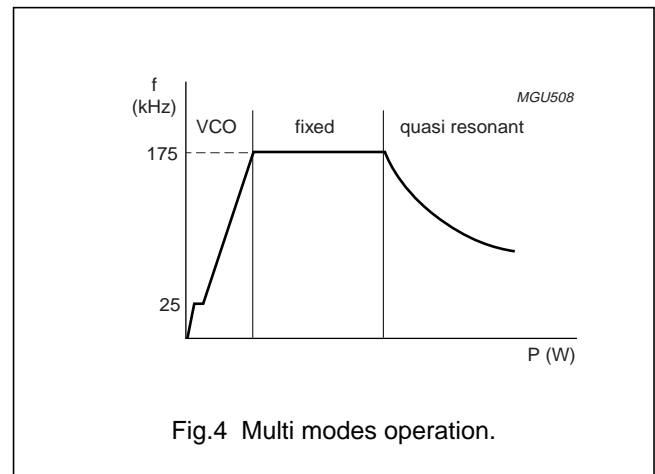

Fig.4 Multi modes operation.

The next converter stroke is started only after demagnetization of the transformer current (zero current switching), while the drain voltage has reached the lowest voltage to prevent switching losses (green function). The primary resonant circuit of the primary inductance and drain capacitor ensures this quasi-resonant operation. The design can be optimized in such a way that zero voltage switching can be reached over almost the universal mains range.

To prevent very high frequency operation at lower loads, the quasi-resonant operation changes smoothly in fixed frequency PWM control.

At very low power (standby) levels, the frequency is controlled down, via the VCO, to a minimum frequency of approximately 25 kHz.

Start-up, mains enabling operation level and undervoltage lock-out

Initially, the IC is self supplying from the rectified mains voltage via pin DRAIN (see Figs 11 and 12). Supply capacitor C_{VCC} is charged by the internal start-up current source to approximately 4 V or higher, depending on the voltage on pin DRAIN.

GreenChip™II SMPS control IC

TEA1533P; TEA1533AP

Once the drain voltage exceeds the M-level (mains-dependent operation-enabling level), the start-up current source will continue charging capacitor C_{VCC} (switch S1 will be opened); see Fig.2. The IC will activate the converter as soon as the voltage on pin V_{CC} passes the $V_{CC(start)}$ level.

The IC supply is taken over by the auxiliary winding as soon as the output voltage reaches its intended level and the IC supply from the mains voltage is subsequently stopped for high efficiency operation (green function).

The moment the voltage on pin V_{CC} drops below the undervoltage lock-out level, the IC stops switching and enters a safe restart from the rectified mains voltage. Inhibiting the auxiliary supply by external means causes the converter to operate in a stable, well defined burst mode.

Supply management

All (internal) reference voltages are derived from a temperature compensated, on-chip band gap circuit.

Current mode control

Current mode control is used for its good line regulation behaviour.

The 'on-time' is controlled by the internally inverted control voltage, which is compared with the primary current information. The primary current is sensed across an external resistor. The driver output is latched in the logic, preventing multiple switch-on.

The internal control voltage is inversely proportional to the external control pin voltage, with an offset of 1.5 V. This means that a voltage range from 1 to 1.5 V on pin CTRL will result in an internal control voltage range from 0.5 to 0 V (a high external control voltage results in a low duty cycle).

Oscillator

The maximum fixed frequency of the oscillator is set by an internal current source and capacitor. The maximum frequency is reduced once the control voltage enters the VCO control window. Then, the maximum frequency changes linearly with the control voltage until the minimum frequency is reached (see Figs 5 and 6).

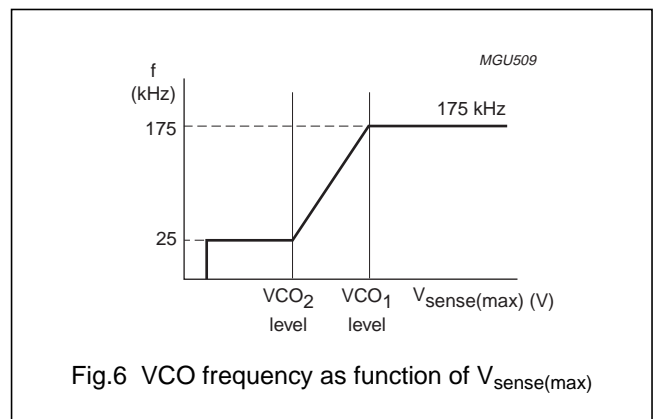
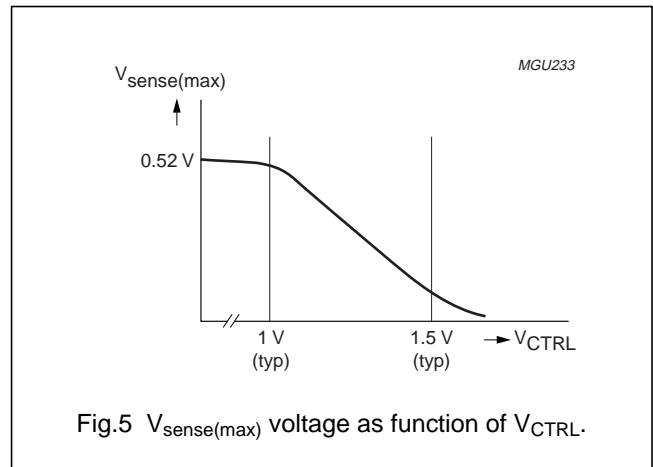

Cycle skipping

At very low power levels, a cycle skipping mode will be activated. A high control voltage will reduce the switching frequency to a minimum of 25 kHz. If the voltage on the control pin is raised even more, switch-on of the external power MOSFET will be inhibited until the voltage on the control pin has dropped to a lower value again (see Fig.7).

For system accuracy, it is not the absolute voltage on the control pin that will trigger the cycle skipping mode, but a signal derived from the internal VCO will be used.

Remark 1: If the no-load requirement of the system is such that the output voltage can be regulated to its intended level at a switching frequency of 25 kHz or above, the cycle skipping mode will not be activated.

Remark 2: As switching will stop when the voltage on the control pin is raised above a certain level, the burst mode has to be activated by a microcontroller or any other circuit sending a 30 μ s, 16 mA pulse to the control input (pin CTRL) of the IC.

GreenChip™II SMPS control IC

TEA1533P; TEA1533AP

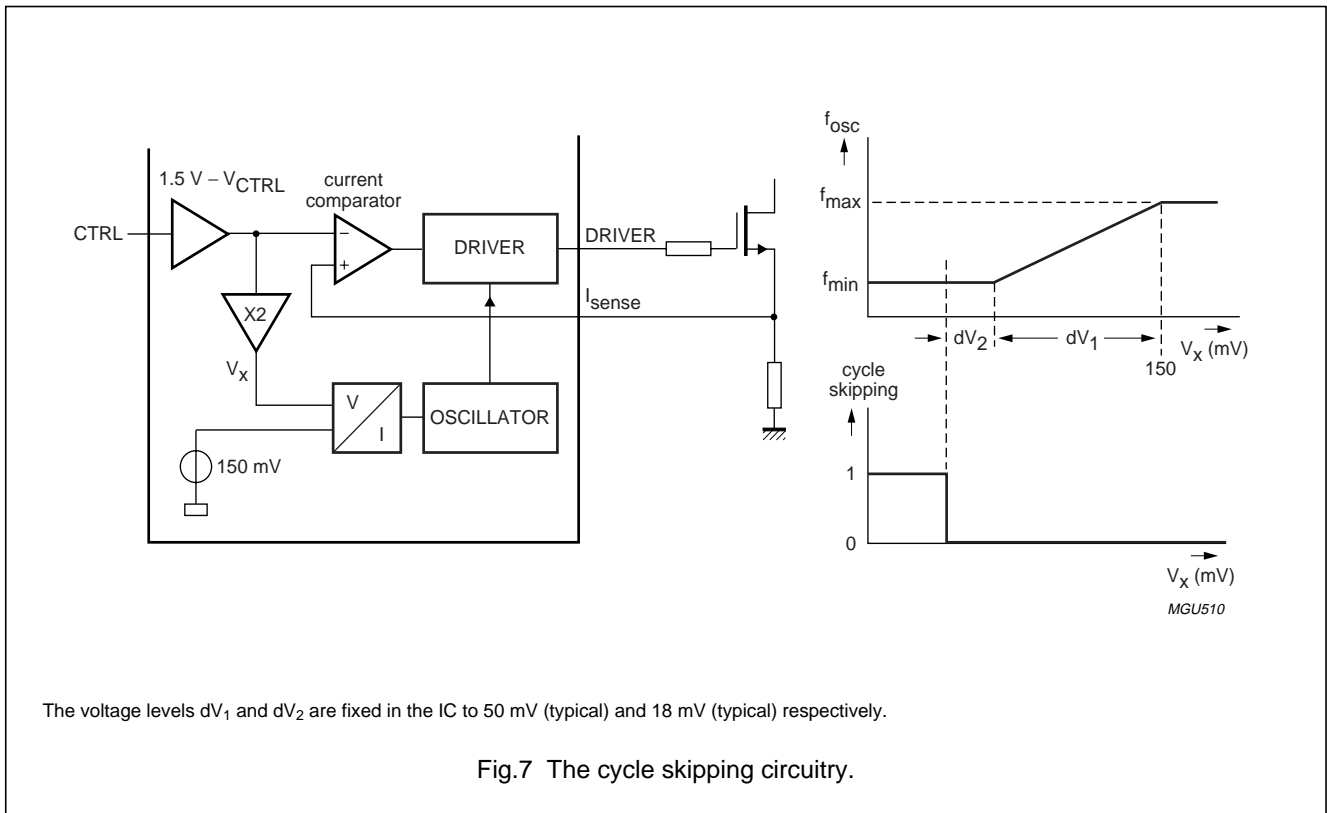

Demagnetization

The system will be in discontinuous conduction mode all the time. The oscillator will not start a new primary stroke until the secondary stroke has ended.

Demagnetization features a cycle-by-cycle output short-circuit protection by immediately lowering the frequency (longer off-time), thereby reducing the power level.

Demagnetization recognition is suppressed during the first t_{suppr} time. This suppression may be necessary in applications where the transformer has a large leakage inductance, at low output voltages and at start-up.

If pin DEM is open-circuit or not connected, a fault condition is assumed and the converter will stop operating immediately. Operation will recommence as soon as the fault condition is removed.

If pin DEM is shorted to ground, again a fault condition is assumed and the converter will stop operating after the first stroke. The converter will subsequently enter the safe restart mode. This situation will persist until the short-circuit is removed.

Minimum and maximum ‘on-time’

The minimum ‘on-time’ of the SMPS is determined by the Leading Edge Blanking (LEB) time. The IC limits the ‘on-time’ to 50 μ s. When the system desires an ‘on-time’ longer than 50 μ s, a fault condition is assumed (e.g. removed C_i in Fig.11), the IC will stop switching and enter the safe restart mode.

GreenChip™II SMPS control IC

TEA1533P; TEA1533AP

OverVoltage Protection (OVP)

An OVP mode is implemented in the GreenChip series. This works for the TEA1533 by sensing the auxiliary voltage via the current flowing into pin DEM during the secondary stroke. The auxiliary winding voltage is a well-defined replica of the output voltage. Any voltage spikes are averaged by an internal filter.

If the output voltage exceeds the OVP trip level, an internal counter starts counting subsequent OVP events. The counter has been added to prevent incorrect OVP detections which might occur during ESD or lightning events. If the output voltage exceeds the OVP trip level a few times and not again in a subsequent cycle, the internal counter will count down with twice the speed compared with counting-up. However, when typical 10 cycles of subsequent OVP events are detected, the IC assumes a true OVP and the OVP circuit switches the power MOSFET off. Next, the controller waits until the UVLO level is reached on pin V_{CC}. When V_{CC} drops to UVLO, capacitor C_{VCC} will be recharged to the V_{start} level.

Regarding the TEA1533P, this IC will not start switching again. Subsequently, V_{CC} will drop again to the UVLO level, etc. Operation only recommences when the V_{CC} voltage drops below a level of approximately 4.5 V (practically when V_{mains} has been disconnected for a short period).

Regarding the TEA1533AP, switching starts again (safe restart mode) when the V_{start} level is reached. This process is repeated as long as the OVP condition exists.

The output voltage V_{o(OVP)} at which the OVP function trips, can be set by the demagnetization resistor, R_{DEM}:

$$V_{o(OVP)} = \frac{N_s}{N_{aux}} \{ I_{(OVP)(DEM)} \times R_{DEM} + V_{clamp(DEM)(pos)} \}$$

where N_s is the number of secondary turns and N_{aux} is the number of auxiliary turns of the transformer.

Current I_{(OVP)(DEM)} is internally trimmed.

The value of R_{DEM} can be adjusted to the turns ratio of the transformer, thus making an accurate OVP possible.

Valley switching

A new cycle starts when the power MOSFET is switched on (see Fig.8). After the ‘on-time’ (which is determined by the ‘sense’ voltage and the internal control voltage), the switch is opened and the secondary stroke starts. After the secondary stroke, the drain voltage shows an oscillation

with a frequency of approximately $\frac{1}{2 \times \pi \times \sqrt{L_p \times C_d}}$

where L_p is the primary self inductance of the transformer and C_d is the capacitance on the drain node.

As soon as the oscillator voltage is high again and the secondary stroke has ended, the circuit waits for the lowest drain voltage before starting a new primary stroke. This method is called valley detection. Figure 8 shows the drain voltage together with the valley signal, the signal indicating the secondary stroke and the oscillator signal.

In an optimum design, the reflected secondary voltage on the primary side will force the drain voltage to zero. Thus, zero voltage switching is very possible, preventing large

capacitive switching losses $(P = \frac{1}{2} \times C \times V^2 \times f)$ and

allowing high frequency operation, which results in small and cost effective inductors.

GreenChip™II SMPS control IC

TEA1533P; TEA1533AP

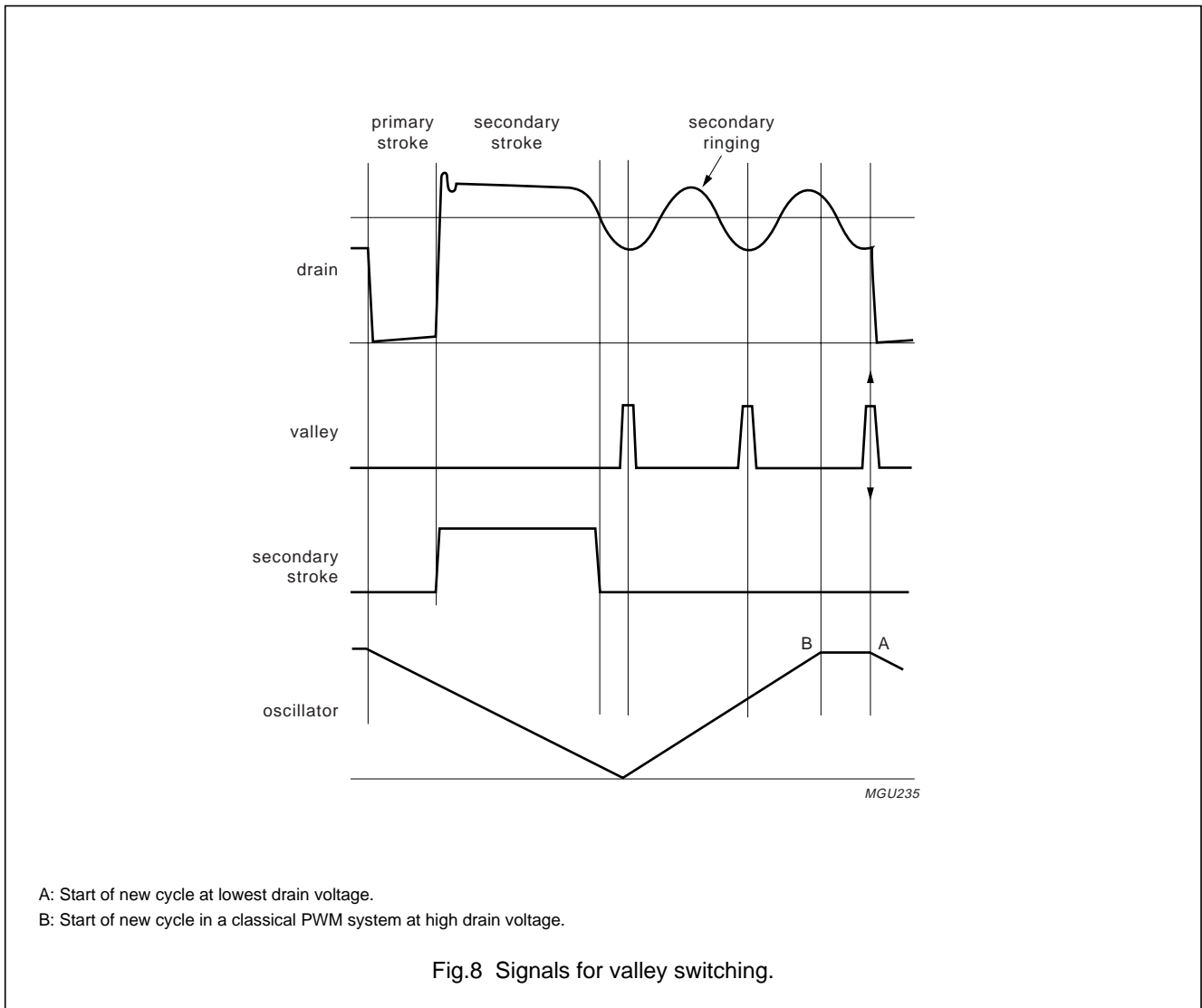

OverCurrent Protection (OCP)

The cycle-by-cycle peak drain current limit circuit uses the external source resistor to measure the current accurately. This allows optimum size determination of the transformer core (cost issue). The circuit is activated after the leading edge blanking time, t_{leb} . The OCP circuit limits the 'sense' voltage to an internal level.

where: $N = \frac{N_{aux}}{N_p}$

The current information is used to adjust the peak drain current, which is measured via pin I_{sense} . The internal compensation is such that an almost mains independent maximum output power can be realized.

OverPower Protection (OPP)

During the primary stroke, the rectified mains input voltage is measured by sensing the current drawn from pin DEM. This current is dependent on the mains voltage, according

The OPP curve is given in Fig.9.

to the following formula: $I_{DEM} \approx \frac{V_{aux}}{R_{DEM}} \approx \frac{N \times V_{mains}}{R_{DEM}}$

GreenChip™II SMPS control IC

TEA1533P; TEA1533AP

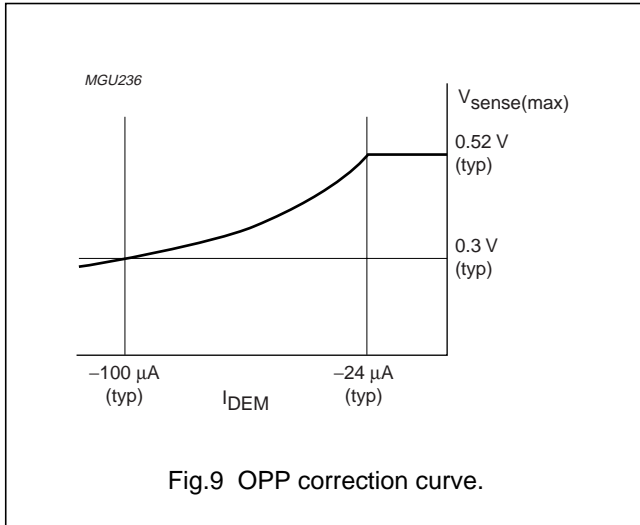

Short winding protection

After the leading edge blanking time, the short winding protection circuit is activated. If the 'sense' voltage exceeds the short winding protection voltage V_{swp} , the converter will stop switching. Once V_{CC} drops below the UVLO level, capacitor C_{VCC} will be recharged and the supply will restart again. This cycle will be repeated until the short-circuit is removed (safe restart mode).

The short winding protection will also protect in case of a secondary diode short-circuit.

OverTemperature Protection (OTP)

An accurate temperature protection is provided in the circuit. When the junction temperature exceeds the thermal shutdown temperature, the IC will stop switching. When V_{CC} drops to UVLO, capacitor C_{VCC} will be recharged to the V_{start} level.

Regarding the TEA1533P, this IC will not start switching again. Subsequently, V_{CC} will drop again to the UVLO level, etc. Operation only recommences when the V_{CC} voltage drops below a level of approximately 4.5 V (practically when the V_{mains} has been disconnected for a short period).

Regarding the TEA1533AP, when the V_{start} level is reached, switching starts again (safe restart mode). This process is repeated as long as the OTP condition exists.

Control pin protection

If pin CTRL is open-circuit or not connected, a fault condition is assumed and the converter will stop switching. Operation will recommence as soon as the fault condition is removed.

Burst mode standby

Pin CTRL is also used to implement the burst mode standby. In burst mode standby, the power supply enters a special low dissipation state. Figure 11 shows a flyback converter using the burst mode standby function. The system enters burst mode standby when the microcontroller activates NPN transistor T1 on the secondary side.

When the voltage on C_{micro} exceeds a certain voltage measured by the microcontroller, the opto-coupler is activated by T1, sending a large current signal to pin CTRL. In response to this signal, the IC stops switching and enters a 'hiccup' mode. This burst activation signal should be present for longer than the 'burst blank' period (typically 30 μs): the blanking time prevents false burst triggering due to spikes. Figure 12 shows the burst mode standby signals. The hiccup mode during burst mode standby operation does not differ from the hiccup mode at safe restart during a system fault condition (e.g. output short-circuit). The power is reduced during soft restart mode.

Burst mode standby operation continues until the microcontroller stops activating transistor T1. The system then enters the start-up sequence and begins normal switching behaviour.

$$I_{burstmode} = \frac{V_{th}}{R_{CTRL}} + I_{th(on)}$$

GreenChip™II SMPS control IC

TEA1533P; TEA1533AP

Soft start-up

To prevent transformer rattle during hiccup, the transformer peak current is slowly increased by the soft start function. This can be achieved by inserting a resistor and a capacitor between pin I_{sense} and the sense resistor (see Fig.10). An internal current source charges the capacitor to $V = I_{SS} \times R_{SS}$, with a maximum of approximately 0.5 V.

The start level and the time constant of the increasing primary current level can be adjusted externally by changing the values of R_{SS} and C_{SS} .

$$I_{primary(max)} = \frac{V_{ocp} - (I_{SS} \times R_{SS})}{R_{sense}}$$

$$\tau = R_{SS} \times C_{SS}$$

The charging current I_{SS} will flow as long as the voltage on pin I_{sense} is below approximately 0.5 V. If the voltage on pin I_{sense} exceeds 0.5 V, the soft start current source will start limiting the current I_{SS} . At the $V_{CC(start)}$ level, the I_{SS} current source is completely switched off.

Since the soft start current I_{SS} is subtracted from pin V_{CC} charging current, the R_{SS} value will affect the V_{CC} charging current level by a maximum of 60 μA (typical value).

Driver

The driver circuit to the gate of the power MOSFET has a current sourcing capability of 170 mA typical and a current sink capability of 700 mA typical. This permits fast turn-on and turn-off of the power MOSFET for efficient operation.

A low driver source current has been chosen to limit the $\Delta V/\Delta t$ at switch-on. This reduces Electro Magnetic Interference (EMI) and also limits the current spikes across R_{sense} .

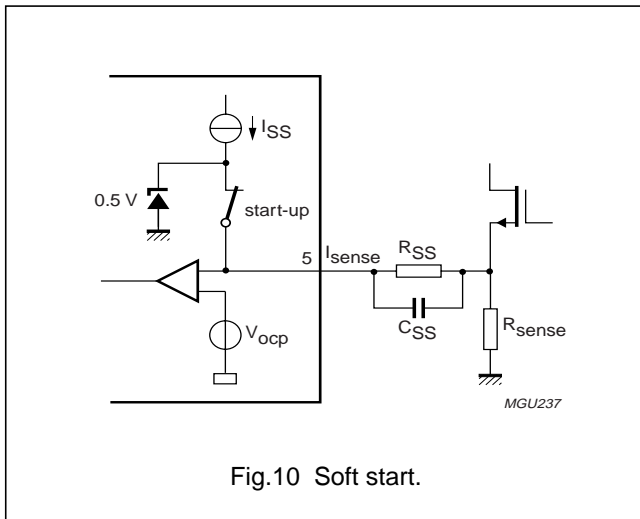

Fig.10 Soft start.

GreenChip™II SMPS control IC

TEA1533P; TEA1533AP

LIMITING VALUES

In accordance with the Absolute Maximum Rating System (IEC 60134); note 1.

SYMBOL	PARAMETER	CONDITIONS	MIN.	MAX.	UNIT
Voltages					
V _{CC}	supply voltage	continuous	-0.4	+20	V
V _{CTRL}	voltage on pin CTRL		-0.4	+5	V
V _{DEM}	voltage on pin DEM	current limited	-0.4	-	V
V _{sense}	voltage on pin I _{sense}	current limited	-0.4	-	V
V _{DRAIN}	voltage on pin DRAIN		-0.4	+650	V
Currents					
I _{CTRL}	current on pin CTRL	d < 10%	-	50	mA
I _{DEM}	current on pin DEM		-250	+250	μA
I _{sense}	current on pin I _{sense}		-1	+10	mA
I _{DRIVER}	current on pin DRIVER	d < 10%	-0.8	+2	A
I _{DRAIN}	current on pin DRAIN		-	5	mA
General					
P _{tot}	total power dissipation	T _{amb} < 70 °C	-	0.75	W
T _{stg}	storage temperature		-55	+150	°C
T _j	operating junction temperature		-20	+145	°C
V _{esd}	electrostatic discharge voltage				
	pins 1 to 6	HBM class 1; note 2	-	2000	V
	pin DRAIN	HBM class 1; note 2	-	1500	V
	any pin	note 3	-	400	V

Notes

- All voltages are measured with respect to ground; positive currents flow into the IC; pin V_{CC} may not be current driven. The voltage ratings are valid provided other ratings are not violated; current ratings are valid provided the maximum power rating is not violated.
- Equivalent to discharging a 100 pF capacitor through a 1.5 kΩ resistor.
- Equivalent to discharging a 200 pF capacitor through a 0.75 μH coil and a 10 Ω resistor.

THERMAL CHARACTERISTICS

SYMBOL	PARAMETER	CONDITIONS	VALUE	UNIT
R _{th(j-a)}	thermal resistance from junction to ambient	in free air; note 1	100	K/W

Note

- With pin GND connected to sufficient copper area on the printed-circuit board.

QUALITY SPECIFICATION

In accordance with 'SNW-FQ-611-D'.

GreenChip™II SMPS control IC

TEA1533P; TEA1533AP

CHARACTERISTICS

$T_{amb} = 25\text{ °C}$; $V_{CC} = 15\text{ V}$; all voltages are measured with respect to ground; currents are positive when flowing into the IC; unless otherwise specified.

SYMBOL	PARAMETER	CONDITIONS	MIN.	TYP.	MAX.	UNIT
Start-up current source (pin DRAIN)						
I_{DRAIN}	supply current drawn from pin DRAIN	$V_{CC} = 0\text{ V}$; $V_{DRAIN} > 100\text{ V}$	1.0	1.2	1.4	mA
		with auxiliary supply; $V_{DRAIN} > 100\text{ V}$	–	100	300	μA
BV_{DSS}	breakdown voltage		650	–	–	V
M-level	mains-dependent operation enabling level		60	–	100	V
Supply voltage management (pin V_{CC})						
$V_{CC(start)}$	start-up voltage on V_{CC}		10.3	11	11.7	V
$V_{CC(UVLO)}$	undervoltage lock-out on V_{CC}		8.1	8.7	9.3	V
$V_{CC(hys)}$	hysteresis voltage on V_{CC}	$V_{CC(start)} - V_{CC(UVLO)}$	2.0	2.3	2.6	V
$I_{CC(h)}$	pin V_{CC} charging current, high	$V_{DRAIN} > 100\text{ V}$; $V_{CC} < 3\text{ V}$	–1.2	–1	–0.8	mA
$I_{CC(l)}$	pin V_{CC} charging current, low	$V_{DRAIN} > 100\text{ V}$; $3\text{ V} < V_{CC} < V_{CC(UVLO)}$	–1.2	–0.75	–0.45	mA
$I_{CC(restart)}$	pin V_{CC} restart current	$V_{DRAIN} > 100\text{ V}$; $V_{CC(UVLO)} < V_{CC} < V_{CC(start)}$	–650	–550	–450	μA
$I_{CC(oper)}$	supply current under normal operation	no load on pin DRIVER	1.1	1.3	1.5	mA
$I_{CC(burstmode)}$	supply current while not switching		–	0.85	–	mA
Demagnetization management (pin DEM)						
$V_{th(DEM)}$	demagnetization comparator threshold voltage on pin DEM		50	100	150	mV
$I_{prot(DEM)}$	protection current on pin DEM	$V_{DEM} = 50\text{ mV}$	–50 ⁽¹⁾	–	–10	nA
$V_{clamp(DEM)(neg)}$	negative clamp voltage on pin DEM	$I_{DEM} = -150\text{ }\mu\text{A}$	–0.5	–0.25	–0.05	V
$V_{clamp(DEM)(pos)}$	positive clamp voltage on pin DEM	$I_{DEM} = 250\text{ }\mu\text{A}$	0.5	0.7	0.9	V
t_{suppr}	suppression of transformer ringing at start of secondary stroke		1.1	1.5	1.9	μs
Pulse width modulator						
$t_{on(min)}$	minimum on-time		–	t_{leb}	–	ns
$t_{on(max)}$	maximum on-time	latched	40	50	60	μs
Oscillator						
$f_{osc(l)}$	oscillator low fixed frequency	$V_{CTRL} > 1.5\text{ V}$	20	25	30	kHz
$f_{osc(h)}$	oscillator high fixed frequency	$V_{CTRL} < 1\text{ V}$	145	175	205	kHz
$V_{vco(start)}$	peak voltage on pin I_{sense} , where frequency reduction starts	see Figs 6 and 7	–	V_{CO1}	–	mV

GreenChip™II SMPS control IC

TEA1533P; TEA1533AP

SYMBOL	PARAMETER	CONDITIONS	MIN.	TYP.	MAX.	UNIT
$V_{VCO(max)}$	peak voltage on pin I_{sense} , where the frequency is equal to $f_{osc(I)}$		–	$V_{CO1} - 25$	–	mV
Duty cycle control (pin CTRL)						
$V_{CTRL(min)}$	minimum voltage on pin CTRL for maximum duty cycle		–	1.0	–	V
$V_{CTRL(max)}$	maximum voltage on pin CTRL for minimum duty cycle		–	1.5	–	V
$I_{prot(CTRL)}$	protection current on pin CTRL	$V_{CTRL} = 1.5\text{ V}$	$-1^{(1)}$	–0.8	–0.5	μA
Burst mode standby (pin CTRL)						
$V_{th(burst)(on)}$	burst mode standby active threshold voltage	$I_{burst} = 6\text{ mA}$	3.3	3.8	4.3	V
$I_{th(burst)(on)}$	burst mode standby active current		16	–	–	mA
$I_{th(burst)(off)}$	burst mode standby inactive current		–	–	6	mA
$t_{(burst-blank)}$	burst mode standby blanking time		25	30	35	μs
Valley switch (pin DRAIN)						
$\Delta V/\Delta t_{valley}$	valley recognition voltage change		–85	–	+85	V/ μs
$t_{valley-swon}$	delay from valley recognition to switch-on		–	150 ⁽¹⁾	–	ns
Overcurrent and short winding protection (pin I_{sense})						
$V_{sense(max)}$	maximum source voltage OCP	$\Delta V/\Delta t = 0.1\text{ V}/\mu\text{s}$	0.48	0.52	0.56	V
t_{PD}	propagating delay from detecting $V_{sense(max)}$ to switch-off	$\Delta V/\Delta t = 0.5\text{ V}/\mu\text{s}$	–	140	185	ns
V_{swp}	short winding protection voltage		0.83	0.88	0.96	V
t_{leb}	blanking time for current and short winding protection		300	370	440	ns
I_{SS}	soft start current	$V_{sense} < 0.5\text{ V}$	45	60	75	μA
Overvoltage protection (pin DEM)						
$I_{OVP(DEM)}$	OVP level on pin DEM	set by resistor R_{DEM} , see Section “OverVoltage Protection (OVP)”	54	60	66	μA
Overpower protection (pin DEM)						
$I_{OPP(DEM)}$	OPP current on pin DEM to start OPP correction	set by resistor R_{DEM} , see Section “OverPower Protection (OPP)”	–	–24	–	μA
$I_{OPP50\%(DEM)}$	OPP current on pin DEM, where maximum source voltage is limited to 0.3 V		–	–100	–	μA

GreenChip™II SMPS control IC

TEA1533P; TEA1533AP

SYMBOL	PARAMETER	CONDITIONS	MIN.	TYP.	MAX.	UNIT
Driver (pin DRIVER)						
I_{source}	source current capability of driver	$V_{\text{CC}} = 9.5 \text{ V}; V_{\text{DRIVER}} = 2 \text{ V}$	–	–170	–88	mA
I_{sink}	sink current capability of driver	$V_{\text{CC}} = 9.5 \text{ V}; V_{\text{DRIVER}} = 2 \text{ V}$	–	300	–	mA
		$V_{\text{CC}} = 9.5 \text{ V}; V_{\text{DRIVER}} = 9.5 \text{ V}$	400	700	–	mA
$V_{\text{o(max)}}$	maximum output voltage of the driver	$V_{\text{CC}} > 12 \text{ V}$	–	11.5	12	V
Temperature protection						
$T_{\text{prot(max)}}$	maximum temperature protection level		130	140	150	°C
$T_{\text{prot(hys)}}$	hysteresis for the temperature protection level		–	8 ⁽¹⁾	–	°C

Note

1. Guaranteed by design.

GreenChip™II SMPS control IC

TEA1533P; TEA1533AP

APPLICATION INFORMATION

A converter with the TEA1533 consists of an input filter, a transformer with a third winding (auxiliary), and an output stage with a feedback circuit.

Capacitor C_{VCC} (at pin V_{CC}) buffers the supply voltage of the IC, which is powered via the high voltage rectified mains during start-up and via the auxiliary winding during operation.

A sense resistor converts the primary current into a voltage at pin I_{sense} . The value of this sense resistor defines the maximum primary peak current.

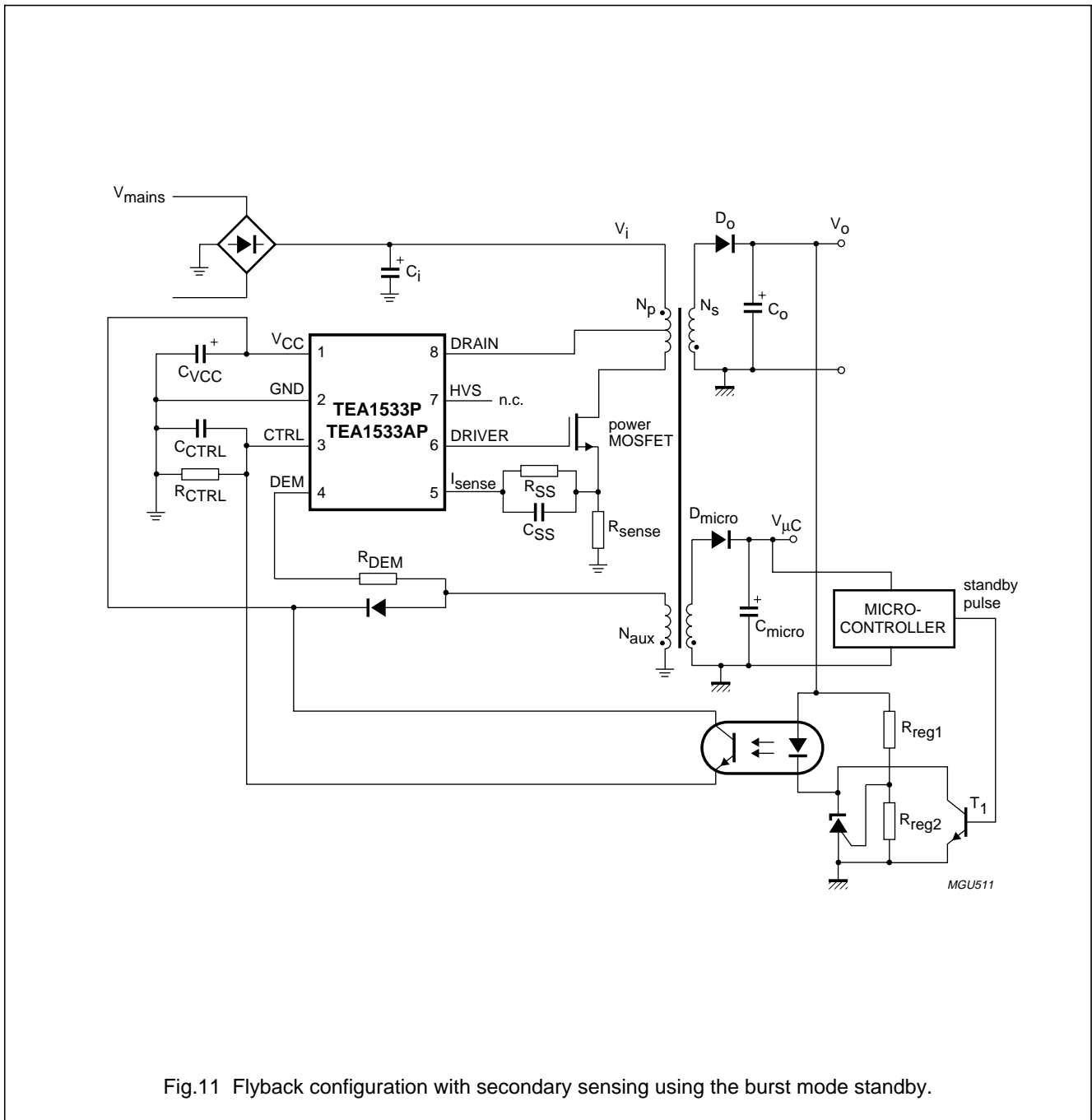

Fig.11 Flyback configuration with secondary sensing using the burst mode standby.

GreenChip™II SMPS control IC

TEA1533P; TEA1533AP

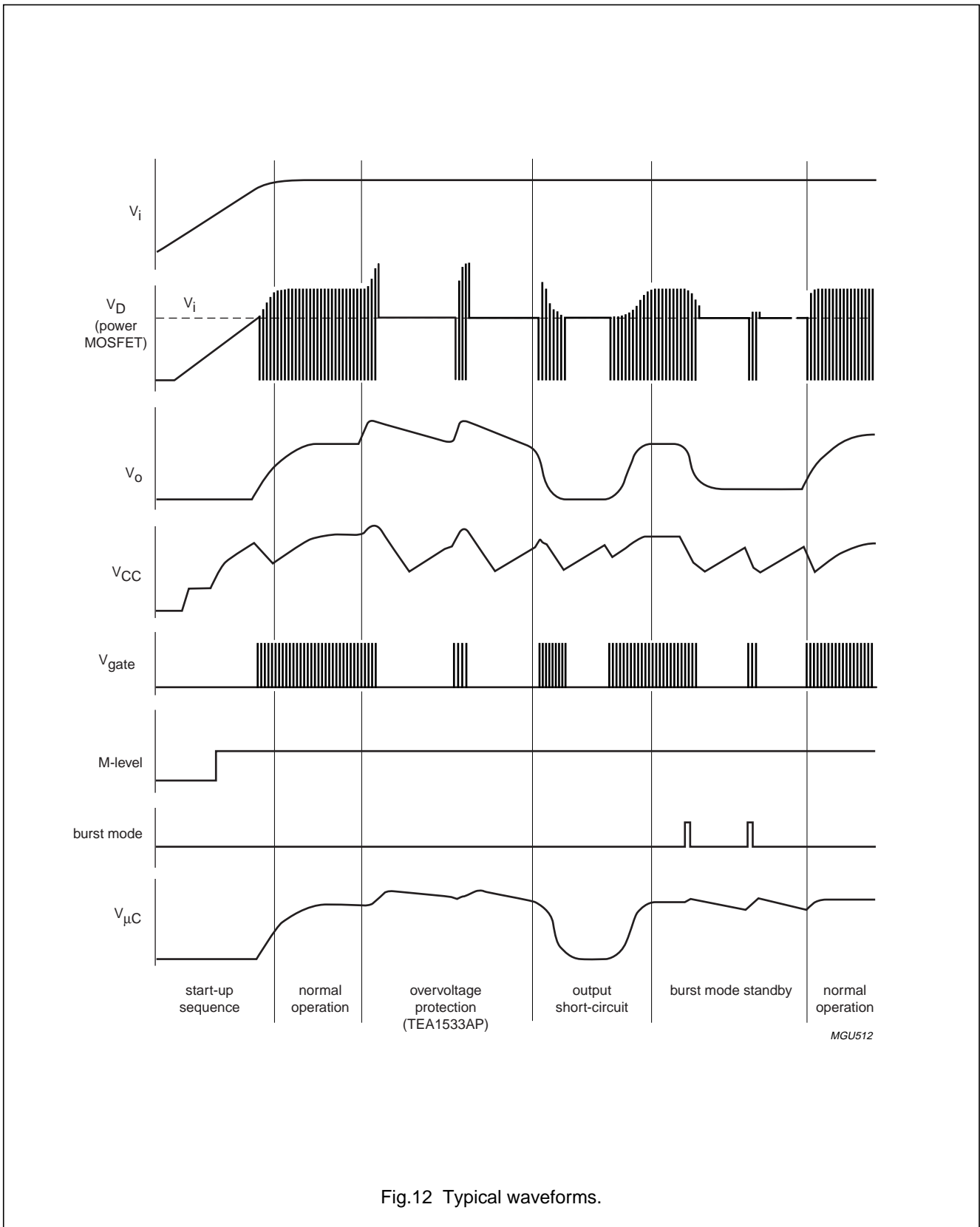

Fig.12 Typical waveforms.

GreenChip™II SMPS control IC

TEA1533P; TEA1533AP

PACKAGE OUTLINE

DIP8: plastic dual in-line package; 8 leads (300 mil)

SOT97-1

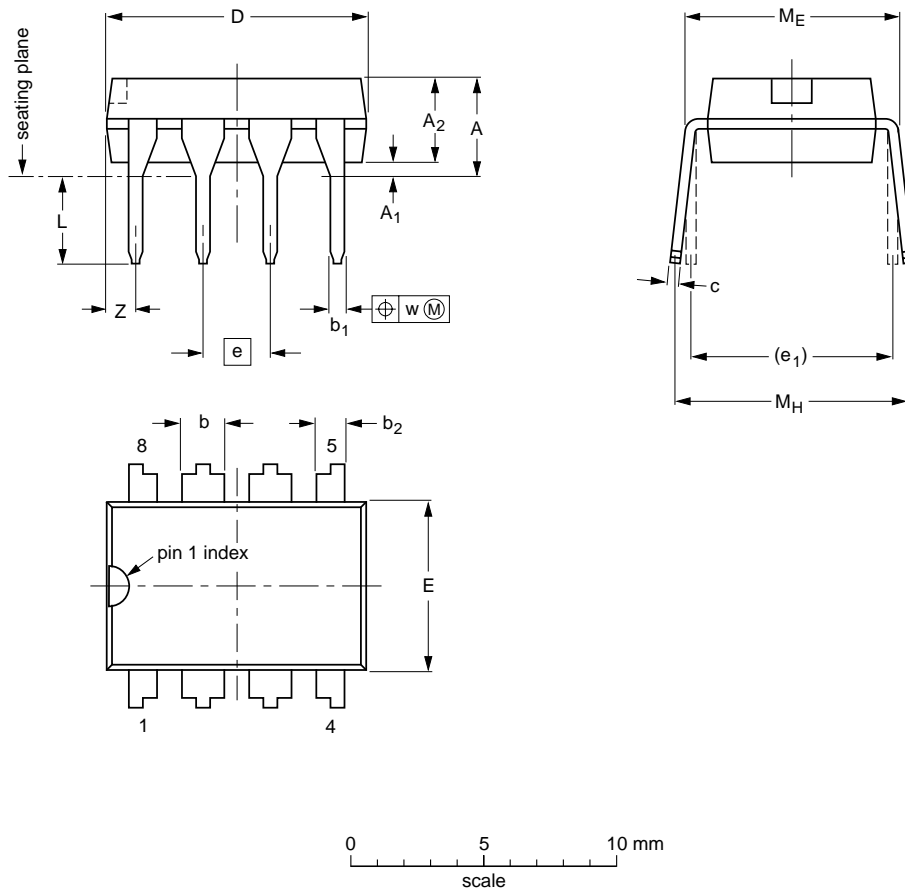

DIMENSIONS (inch dimensions are derived from the original mm dimensions)

UNIT	A max.	A ₁ min.	A ₂ max.	b	b ₁	b ₂	c	D ⁽¹⁾	E ⁽¹⁾	e	e ₁	L	M _E	M _H	w	Z ⁽¹⁾ max.
mm	4.2	0.51	3.2	1.73 1.14	0.53 0.38	1.07 0.89	0.36 0.23	9.8 9.2	6.48 6.20	2.54	7.62	3.60 3.05	8.25 7.80	10.0 8.3	0.254	1.15
inches	0.17	0.020	0.13	0.068 0.045	0.021 0.015	0.042 0.035	0.014 0.009	0.39 0.36	0.26 0.24	0.10	0.30	0.14 0.12	0.32 0.31	0.39 0.33	0.01	0.045

Note

1. Plastic or metal protrusions of 0.25 mm maximum per side are not included.

OUTLINE VERSION	REFERENCES			EUROPEAN PROJECTION	ISSUE DATE
	IEC	JEDEC	EIAJ		
SOT97-1	050G01	MO-001	SC-504-8		95-02-04 99-12-27

GreenChip™II SMPS control IC

TEA1533P; TEA1533AP

SOLDERING**Introduction to soldering through-hole mount packages**

This text gives a brief insight to wave, dip and manual soldering. A more in-depth account of soldering ICs can be found in our *"Data Handbook IC26; Integrated Circuit Packages"* (document order number 9398 652 90011).

Wave soldering is the preferred method for mounting of through-hole mount IC packages on a printed-circuit board.

Soldering by dipping or by solder wave

The maximum permissible temperature of the solder is 260 °C; solder at this temperature must not be in contact with the joints for more than 5 seconds.

The total contact time of successive solder waves must not exceed 5 seconds.

The device may be mounted up to the seating plane, but the temperature of the plastic body must not exceed the specified maximum storage temperature ($T_{stg(max)}$). If the printed-circuit board has been pre-heated, forced cooling may be necessary immediately after soldering to keep the temperature within the permissible limit.

Manual soldering

Apply the soldering iron (24 V or less) to the lead(s) of the package, either below the seating plane or not more than 2 mm above it. If the temperature of the soldering iron bit is less than 300 °C it may remain in contact for up to 10 seconds. If the bit temperature is between 300 and 400 °C, contact may be up to 5 seconds.

Suitability of through-hole mount IC packages for dipping and wave soldering methods

PACKAGE	SOLDERING METHOD	
	DIPPING	WAVE
DBS, DIP, HDIP, SDIP, SIL	suitable	suitable ⁽¹⁾

Note

- For SDIP packages, the longitudinal axis must be parallel to the transport direction of the printed-circuit board.

GreenChip™II SMPS control IC

TEA1533P; TEA1533AP

DATA SHEET STATUS

DATA SHEET STATUS ⁽¹⁾	PRODUCT STATUS ⁽²⁾	DEFINITIONS
Objective data	Development	This data sheet contains data from the objective specification for product development. Philips Semiconductors reserves the right to change the specification in any manner without notice.
Preliminary data	Qualification	This data sheet contains data from the preliminary specification. Supplementary data will be published at a later date. Philips Semiconductors reserves the right to change the specification without notice, in order to improve the design and supply the best possible product.
Product data	Production	This data sheet contains data from the product specification. Philips Semiconductors reserves the right to make changes at any time in order to improve the design, manufacturing and supply. Changes will be communicated according to the Customer Product/Process Change Notification (CPCN) procedure SNW-SQ-650A.

Notes

1. Please consult the most recently issued data sheet before initiating or completing a design.
2. The product status of the device(s) described in this data sheet may have changed since this data sheet was published. The latest information is available on the Internet at URL <http://www.semiconductors.philips.com>.

DEFINITIONS

Short-form specification — The data in a short-form specification is extracted from a full data sheet with the same type number and title. For detailed information see the relevant data sheet or data handbook.

Limiting values definition — Limiting values given are in accordance with the Absolute Maximum Rating System (IEC 60134). Stress above one or more of the limiting values may cause permanent damage to the device. These are stress ratings only and operation of the device at these or at any other conditions above those given in the Characteristics sections of the specification is not implied. Exposure to limiting values for extended periods may affect device reliability.

Application information — Applications that are described herein for any of these products are for illustrative purposes only. Philips Semiconductors make no representation or warranty that such applications will be suitable for the specified use without further testing or modification.

DISCLAIMERS

Life support applications — These products are not designed for use in life support appliances, devices, or systems where malfunction of these products can reasonably be expected to result in personal injury. Philips Semiconductors customers using or selling these products for use in such applications do so at their own risk and agree to fully indemnify Philips Semiconductors for any damages resulting from such application.

Right to make changes — Philips Semiconductors reserves the right to make changes, without notice, in the products, including circuits, standard cells, and/or software, described or contained herein in order to improve design and/or performance. Philips Semiconductors assumes no responsibility or liability for the use of any of these products, conveys no licence or title under any patent, copyright, or mask work right to these products, and makes no representations or warranties that these products are free from patent, copyright, or mask work right infringement, unless otherwise specified.

GreenChip™II SMPS control IC

TEA1533P; TEA1533AP

NOTES

GreenChip™II SMPS control IC

TEA1533P; TEA1533AP

NOTES

GreenChip™II SMPS control IC

TEA1533P; TEA1533AP

NOTES

Philips Semiconductors – a worldwide company

Contact information

For additional information please visit <http://www.semiconductors.philips.com>. Fax: +31 40 27 24825

For sales offices addresses send e-mail to: sales.addresses@www.semiconductors.philips.com.

© Koninklijke Philips Electronics N.V. 2002

SCA74

All rights are reserved. Reproduction in whole or in part is prohibited without the prior written consent of the copyright owner.

The information presented in this document does not form part of any quotation or contract, is believed to be accurate and reliable and may be changed without notice. No liability will be accepted by the publisher for any consequence of its use. Publication thereof does not convey nor imply any license under patent- or other industrial or intellectual property rights.

Printed in The Netherlands

613502/02/pp24

Date of release: 2002 Aug 23

Document order number: 9397 750 10261

Let's make things better.

**Philips
Semiconductors**



PHILIPS