

阅读申明

- 1.本站收集的数据手册和产品资料都来自互联网，版权归原作者所有。如读者和版权方有任何异议请及时告之，我们将妥善解决。
- 2.本站提供的中文数据手册是英文数据手册的中文翻译，其目的是协助用户阅读，该译文无法自动跟随原稿更新，同时也可能存在翻译上的不当。建议读者以英文原稿为参考以便获得更精准的信息。
- 3.本站提供的产品资料，来自厂商的技术支持或者使用者的心得体会等，其内容可能存在描述上的差异，建议读者做出适当判断。
- 4.如需与我们联系，请发邮件到marketing@iczoom.com，主题请标有“数据手册”字样。

Read Statement

1. The datasheets and other product information on the site are all from network reference or other public materials, and the copyright belongs to the original author and original published source. If readers and copyright owners have any objections, please contact us and we will deal with it in a timely manner.
2. The Chinese datasheets provided on the website is a Chinese translation of the English datasheets. Its purpose is for reader's learning exchange only and do not involve commercial purposes. The translation cannot be automatically updated with the original manuscript, and there may also be improper translations. Readers are advised to use the English manuscript as a reference for more accurate information.
3. All product information provided on the website refer to solutions from manufacturers' technical support or users the contents may have differences in description, and readers are advised to take the original article as the standard.
4. If you have any questions, please contact us at marketing@iczoom.com and mark the subject with "Datasheets" .

Structure : Silicon Monolithic Integrated Circuit
 Product Name : BLT Driver For CD-ROM

Device Name : **BA5954FP**

- Features :
- 2CHs for current driving-type BLT drivers to drive two-axis actuators
 - 1CH for a voltage driving-type BTL driver for a feed motor
 4-ch comprising of 1CH for a voltage driving-type BTL driver for a loading motor
 - A wide dynamic range (PreVcc=12V, PVcc=5V, 4.0V(Typ) when RL=8Ω)
 - The pre-part + feed motor part, the loading motor part, and the actuator part are provided with power supplies independently and its low voltage operation achieves an efficient drive.
 - A built-in level shift circuit
 - A built-in thermal shutdown circuit is installed
 - A built-in standby function installed.
- <Two-axis Actuator Driver>
 The current feedback technique can reduce the current phase shift caused by the load inductance.
- <Feed Motor Driver>
 A general op-amp connected to the input terminal helps compute additions of differential inputs or signals.
- <Loading Driver>
 A tri-state logic input is used to determine a forward or reverse operation. It can be used as a linear BTL driver.

○ ABSOLUTE MAXIMUM RATINGS

Parameter	Symbol	Limits	Unit
Power Supply Voltage	Vcc, PVcc1/2	13.5	V
Power Dissipation	Pd	1.7*1	W
Operating Temperature Range	Topr	-35 to 85	°C
Storage Temperature Range	Tstg	-55 to 150	°C

*1 When mounted on PCB(the glass/epoxy board with the size: 70 mm×70 mm, the thickness: 1.6 mm).
 Over Ta=25°C, derating at the rate of 13.6mW/°C.

○ RECOMMENDED OPERATING CONDITIONS

Parameter	Symbol	Limits	Unit
Power Supply Voltage	Vcc	4.3 to 13.2	V
	PVcc1	4.3 to Vcc	V
	PVcc2	4.3 to Vcc	V

This product has not been checked for the strategic materials (or service) defined in the Foreign Exchange and Foreign Trade Control Law of Japan so that a verification work is required before exporting it.

Not designed for radiation resistance.

○ ELECTRIC CHARACTERISTICS (Ta=25°C, Vcc=12V, PVcc1=PVcc2=5V, BIAS=2.5V, RL=8Ω, Rd=0.5Ω, C=100pF, unless otherwise noted)

Parameter	Symbol	MIN.	TYP.	MAX.	Unit	Condition
Consumption Current (at no signal)	I _{CC}	-	18	27	mA	
Standby Circuit Current	I _{ST}	-	-	0.5	mA	
Standby ON Voltage	V _{STON}	0	-	0.5	V	
Standby OFF Voltage	V _{STOFF}	2.0	-	-	V	
<Actuator Driver>						
Output Offset Current	I _{OO}	-6	-	6	mA	
Maximum Output Amplitude	V _{OM}	3.6	4.0	-	V	
Transfer Gain	g _m	1.3	1.5	1.7	A/V	V _{IN} =BIAS ± 0.2V
<Feed Motor Driver>						
Input OP Amp Common Mode Input Range	V _{ICM}	-0.3	-	11.0	V	
Input Bias Current (Discharge Current)	I _{BOP}	-	30	300	nA	
L-level Output Voltage	V _{OLOP}	-	0.1	0.3	V	
Maximum Output Source Current	I _{SO}	0.3	0.5	-	mA	
Maximum Output Sink Current	I _{SI}	1	-	-	mA	
Output Offset Voltage	V _{OOFSL}	-100	0	100	mV	
Maximum Output Amplitude	V _{OMSL}	7.5	9.0	-	V	
Closed Circuit Voltage Gain	G _{VSL}	18.0	20.0	22.0	dB	V _{in} =±0.2V
<Loading Driver>						
Offset Voltage	V _{OOFD}	-50	0	50	mV	
Maximum Output Amplitude	V _{OMD}	3.6	4.0	-	V	
Voltage Gain	G _{VLD}	13.5	15.5	17.5	dB	V _{IN} =BIAS ± 0.2V
F · R Gain Difference	ΔG _{VLD0}	0	1	2	dB	V _{IN} =BIAS ± 0.2V

○ OUTLINE DIMENSIONS, SYMBOLS

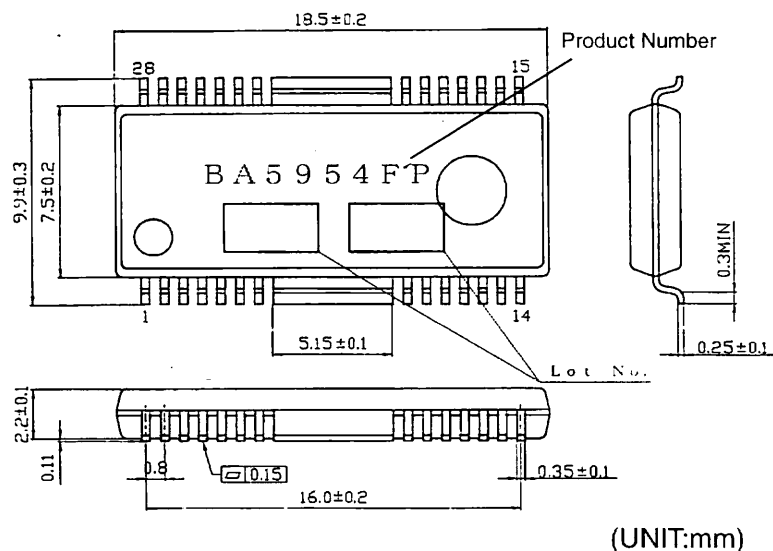

(UNIT:mm)

○ APPLICATION CIRCUIT DIAGRAM

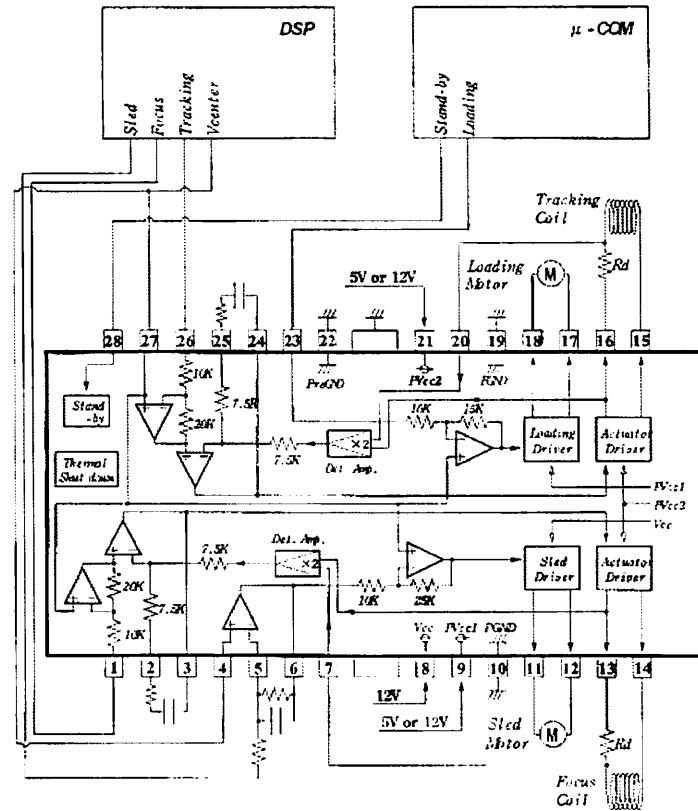

○ PIN NUMBERS, PIN NAMES

No.	Pin Name	Description	No.	Pin Name	Description
1	VINFC	Focus driver input	15	VOTK+	Tracking driver output (+)
2	CFCerr1	Capacitor connection terminal for error amp filter	16	VOTK-	Tracking driver output (-)
3	CFCerr2	Capacitor connection terminal for error amp filter	17	VOLD+	Loading driver output (+)
4	VINSL+	Op amp input (+) for Sled driver	18	VOLD-	Loading driver output (-)
5	VINSL-	Op amp input (-) for Sled driver	19	PGND	Power GND
6	VOSL	Op amp output for Sled driver	20	VNFTK	Tracking driver feedback terminal
7	VINFFC	Focus driver feedback terminal	21	PVcc2	Actuator driver part power Vcc
8	VCC	Pre Vcc. Sled driver part power Vcc	22	PreGND	Pre GND
9	PVCC1	Loading driver part power Vcc	23	VINLD	Loading driver input
10	PGND	Power GND	24	CTKerr1	Capacitor connection terminal for error amp filter
11	VOSL-	Sled driver part output (-)	25	CTKerr2	Capacitor connection terminal for error amp filter
12	VOSL+	Sled driver part output (+)	26	VINTK	Tracking driver input
13	VOFC-	Focus driver output (-)	27	BIAS	Bias input
14	VOFC+	Focus driver output (+)	28	STBY	Standby terminal

Notes The polarity signs shown in the output terminal names indicate the polarities when corresponding input pins are set to (+).

On the power supply terminals of the output H bridge, PVcc2 is set for the focus and tracking drivers, PVcc1 for loading, and Vcc for feed motor.

The power supply systems of the pre part are all set to Vcc.

Make sure that this device must be used under the following condition: Vcc ≥ PVcc.

○ CAUTIONS ON USE

- (1) Setting the Standby terminal to open or 0.5V or less allows the circuit current to be set in the standby mode.
- (2) When the power supply voltage (Vcc) drops to 3.5V (Typ.) or less, the mute function will be activated and, when recovering to 3.7V (Typ.) or above, the circuit will startup again.
- (3) On the Bias terminal, the applied voltage of 0.9V (Typ.) or less will activate a mute function. Under conditions of normal use, it should be set to 12V or above.
- (4) About absolute maximum ratings
Exceeding the absolute maximum ratings, such as the applied voltage or the operating temperature range, may cause permanent device damage. As these cases cannot be limited to the broken short mode or the open mode, if a special mode where the absolute maximum ratings may be exceeded is assumed, it is recommended to take mechanical safety measures such as attaching fuses.
- (5) About power supply lines
As a measure against the back current regenerated by a counter electromotive force of the motor, a capacitor to be used as a regenerated-current path can be installed between the power supply and GND and its capacitance value should be determined after careful check that any problems, for example, a leak capacitance of the electrolytic capacitor at low temperature, are not found in various characteristics.
- (6) About GND potential
The electric potential of the GND terminal must be kept lowest in the circuitry at any operation states.
- (7) About thermal design
With consideration of the power dissipation (Pd) under conditions of actual use, a thermal design provided with an enough margin should be done.
- (8) About operations in a strong electric field
When used in a strong electric field, note that a malfunction may occur.
- (9) ASO
When using this IC, the output Tr. must be set not to exceed the values specified in the absolute maximum ratings and ASO.
- (10) Thermal shutdown circuit (Thermal shutdown: TSD)
This IC incorporates a thermal shutdown circuit (TSD circuit). When the chip temperature reaches the value shown below, the coil output to the motor will be set to open.
The thermal shutdown circuit is designed only to shut off the IC from a thermal runaway and not intended to protect or guarantee the entire IC functions.
Therefore, users cannot assume that the TSD circuit once activated can be used continuously in the subsequent operations.

TSD ON Temperature [°C] (typ.)	Hysteresis Temperature [°C] (typ.)
175	25

- (11) About earth wiring patterns
When a small signal GND and a large current GND are provided, it is recommended that the large current GND pattern and the small signal GND pattern should be separated and grounded at a single point of the reference point of the set in order to prevent the voltage of the small signal GND from being affected by a voltage change caused by the resistance of the pattern wiring and the large current. Make sure that the GND wiring patterns of the external components will not change, too.
- (12) This IC is a monolithic IC which has a P⁺ isolations and P substrate to isolate elements each other. This P layer and an N layer in each element form a PN junction to construct various parasitic elements. Due to the IC structure, the parasitic elements are inevitably created by the potential relationship. Activation of the parasitic elements can cause interference between circuits and may result in a malfunction or, consequently, a fatal damage. Therefore, make sure that the IC must not be used under conditions that may activate the parasitic elements, for example, applying the lower voltage than the ground level (GND, P substrate) to the input terminals.
In addition, do not apply the voltage to input terminals without applying the power supply voltage to the IC. Also while applying the power supply voltage, each input terminal must not be over the power supply voltage, or within the guaranteed values in the electric characteristics.

<Supplemental Remarks>

Current feedback driver

The transfer gain (output current / input current) can be determined by the following equation:

$$g_m = \frac{1}{R_d + R_{WIRE}} \quad (A/V)$$

Where R_{WIRE} represents a gold wire resistance inside the package, measuring approximately 0.15Ω ($\pm 0.05\Omega$) (Typ.)

Notes

- No technical content pages of this document may be reproduced in any form or transmitted by any means without prior permission of ROHM CO.,LTD.
- The contents described herein are subject to change without notice. The specifications for the product described in this document are for reference only. Upon actual use, therefore, please request that specifications to be separately delivered.
- Application circuit diagrams and circuit constants contained herein are shown as examples of standard use and operation. Please pay careful attention to the peripheral conditions when designing circuits and deciding upon circuit constants in the set.
- Any data, including, but not limited to application circuit diagrams information, described herein are intended only as illustrations of such devices and not as the specifications for such devices. ROHM CO.,LTD. disclaims any warranty that any use of such devices shall be free from infringement of any third party's intellectual property rights or other proprietary rights, and further, assumes no liability of whatsoever nature in the event of any such infringement, or arising from or connected with or related to the use of such devices.
- Upon the sale of any such devices, other than for buyer's right to use such devices itself, resell or otherwise dispose of the same, no express or implied right or license to practice or commercially exploit any intellectual property rights or other proprietary rights owned or controlled by
- ROHM CO., LTD. is granted to any such buyer.
- Products listed in this document are no antiradiation design.

The products listed in this document are designed to be used with ordinary electronic equipment or devices (such as audio visual equipment, office-automation equipment, communications devices, electrical appliances and electronic toys).

Should you intend to use these products with equipment or devices which require an extremely high level of reliability and the malfunction of which would directly endanger human life (such as medical instruments, transportation equipment, aerospace machinery, nuclear-reactor controllers, fuel controllers and other safety devices), please be sure to consult with our sales representative in advance.

About Export Control Order in Japan

Products described herein are the objects of controlled goods in Annex 1 (Item 16) of Export Trade Control Order in Japan.

In case of export from Japan, please confirm if it applies to "objective" criteria or an "informed" (by MITI clause) on the basis of "catch all controls for Non-Proliferation of Weapons of Mass Destruction.

Thank you for your accessing to ROHM product informations.
More detail product informations and catalogs are available,
please contact your nearest sales office.

Please contact our sales offices for details ;

U.S.A / San Diego	TEL : +1(858)625-3630	FAX : +1(858)625-3670
Atlanta	TEL : +1(770)754-5972	FAX : +1(770)754-0691
Dallas	TEL : +1(972)312-8818	FAX : +1(972)312-0330
Germany / Dusseldorf	TEL : +49(2154)9210	FAX : +49(2154)921400
United Kingdom / London	TEL : +44(1)908-282-666	FAX : +44(1)908-282-528
France / Paris	TEL : +33(0)1 56 97 30 60	FAX : +33(0) 1 56 97 30 80
China / Hong Kong	TEL : +852(2)740-6262	FAX : +852(2)375-8971
Shanghai	TEL : +86(21)6279-2727	FAX : +86(21)6247-2066
Dilian	TEL : +86(411)8230-8549	FAX : +86(411)8230-8537
Beijing	TEL : +86(10)8525-2483	FAX : +86(10)8525-2489
Taiwan / Taipei	TEL : +866(2)2500-6956	FAX : +866(2)2503-2869
Korea / Seoul	TEL : +82(2)8182-700	FAX : +82(2)8182-715
Singapore	TEL : +65-6332-2322	FAX : +65-6332-5662
Malaysia / Kuala Lumpur	TEL : +60(3)7958-8355	FAX : +60(3)7958-8377
Philippines / Manila	TEL : +63(2)807-6872	FAX : +63(2)809-1422
Thailand / Bangkok	TEL : +66(2)254-4890	FAX : +66(2)256-6334

Japan /
(Internal Sales)

Tokyo	2-1-1, Yaesu, Chuo-ku, Tokyo 104-0082	TEL : +81(3)5203-0321	FAX : +81(3)5203-0300
Yokohama	2-4-8, Shin Yokohama, Kohoku-ku, Yokohama, Kanagawa 222-8575	TEL : +81(45)476-2131	FAX : +81(45)476-2128
Nagoya	Dainagayo Building 9F 3-28-12, Meieki, Nakamura-ku, Nagoya, Aichi 450-0002	TEL : +81(52)581-8521	FAX : +81(52)561-2173
Kyoto	579-32 Higashi Shiokouji-cho, Karasuma Nishi-iru, Shiokoujidori, Shimogyo-ku, Kyoto 600-8216	TEL : +81(75)311-2121	FAX : +81(75)314-6559

(Contact address for overseas customers in Japan)

Yokohama	TEL : +81(45)476-9270	FAX : +81(045)476-9271
----------	-----------------------	------------------------