

## 阅读申明

- 1.本站收集的数据手册和产品资料都来自互联网，版权归原作者所有。如读者和版权方有任何异议请及时告之，我们将妥善解决。
- 2.本站提供的中文数据手册是英文数据手册的中文翻译，其目的是协助用户阅读，该译文无法自动跟随原稿更新，同时也可能存在翻译上的不当。建议读者以英文原稿为参考以便获得更精准的信息。
- 3.本站提供的产品资料，来自厂商的技术支持或者使用者的心得体会等，其内容可能存在描述上的差异，建议读者做出适当判断。
- 4.如需与我们联系，请发邮件到marketing@iczoom.com，主题请标有“数据手册”字样。

## Read Statement

1. The datasheets and other product information on the site are all from network reference or other public materials, and the copyright belongs to the original author and original published source. If readers and copyright owners have any objections, please contact us and we will deal with it in a timely manner.
2. The Chinese datasheets provided on the website is a Chinese translation of the English datasheets. Its purpose is for reader's learning exchange only and do not involve commercial purposes. The translation cannot be automatically updated with the original manuscript, and there may also be improper translations. Readers are advised to use the English manuscript as a reference for more accurate information.
3. All product information provided on the website refer to solutions from manufacturers' technical support or users the contents may have differences in description, and readers are advised to take the original article as the standard.
4. If you have any questions, please contact us at marketing@iczoom.com and mark the subject with "Datasheets" .

# High Speed Triple Laser Diode Drivers

## ISL58315

The ISL58315 is a high-speed, triple-output laser diode driver (LDD) for laser scanning projector systems, which require three channels modulated at high speed with independent current control.

Each output channel provides laser-independent current control for threshold and color DACs. Separate scale DACs allow independent scaling of both threshold and color DAC output values. This allows control of projector brightness and can be used to simplify automatic power calibration (APC) for laser-based systems.

Pixel data information is transferred through the LDD's high-speed 10-bit or 15-bit parallel video interface. Three parallel interface modes provide flexibility and allow users a trade-off among speed, power and bus width. Pixel data employs a double data rate scheme, allowing video data to be transferred using both clock edges.

### Applications

- Laser-based Pico Projectors
- RGB Scanning and Field-based laser projection systems
- Generic laser-based applications requiring multiple, independently controlled lasers

### Related Literature

- See application block diagram for Pico Projector (MEMS) at: <http://www.intersil.com/applications/PicoProjector%28MEMS%29.asp>

### Features

- High-speed, triple-output laser diode driver supporting up to 720-pixel HD resolution
- Up to 1A of peak current output
- Fast output switching speeds with pulse rise/fall times of 1ns to 2ns for crisp pixels
- Intersil patented laser voltage sampler function provides dynamic power management capability to dramatically minimize system power
- Intersil patented SmartLinearizer™ DAC feature provides a linear transfer function (input video code to green laser output), eliminating the need for DSP controller processing algorithms required for non-linear green lasers
- Flexible 10-bit or Intersil patented 15-bit RGB pixel input formats supported to reduce speed and power. 300MHz maximum data Input rate supported for 10-bit RGB mode
- Blanking time power reduction reduces LDD current consumption to 3mA typical
- Programmable return-to-zero (RTZ) function provides maximum flexibility
- Integrated heater function for SHG green lasers reduces external components
- Single 3.3V supply and 1.8V video interface compatible for low power

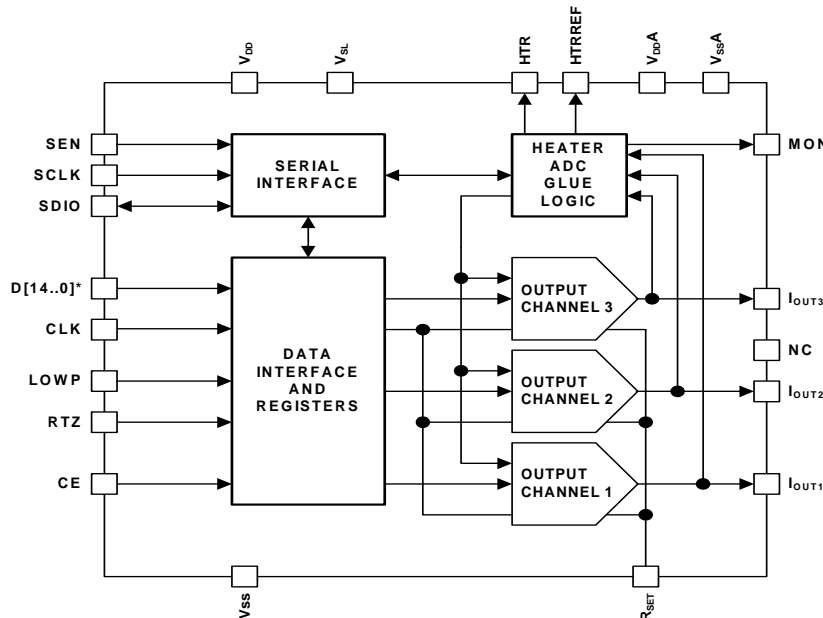

NOTE:  
\* THE FOLLOWING DATA LINES HAVE ALTERNATIVE USE, DEPENDING ON REGISTER SETTING: D2 = EN3, D4 = EN2, D6 = EN1, AND D10 = SYNC

FIGURE 1. BLOCK DIAGRAM

**CONFIDENTIAL**

For additional products, see [www.intersil.com/product\\_tree](http://www.intersil.com/product_tree)

---

Intersil products are manufactured, assembled and tested utilizing ISO9000 quality systems as noted in the quality certifications found at [www.intersil.com/design/quality](http://www.intersil.com/design/quality)

---

*Intersil products are sold by description only. Intersil Corporation reserves the right to make changes in circuit design, software and/or specifications at any time without notice. Accordingly, the reader is cautioned to verify that data sheets are current before placing orders. Information furnished by Intersil is believed to be accurate and reliable. However, no responsibility is assumed by Intersil or its subsidiaries for its use; nor for any infringements of patents or other rights of third parties which may result from its use. No license is granted by implication or otherwise under any patent or patent rights of Intersil or its subsidiaries.*

---

For information regarding Intersil Corporation and its products, see [www.intersil.com](http://www.intersil.com)