

## 阅读申明

- 1.本站收集的数据手册和产品资料都来自互联网，版权归原作者所有。如读者和版权方有任何异议请及时告之，我们将妥善解决。
- 2.本站提供的中文数据手册是英文数据手册的中文翻译，其目的是协助用户阅读，该译文无法自动跟随原稿更新，同时也可能存在翻译上的不当。建议读者以英文原稿为参考以便获得更精准的信息。
- 3.本站提供的产品资料，来自厂商的技术支持或者使用者的心得体会等，其内容可能存在描述上的差异，建议读者做出适当判断。
- 4.如需与我们联系，请发邮件到marketing@iczoom.com，主题请标有“数据手册”字样。

## Read Statement

1. The datasheets and other product information on the site are all from network reference or other public materials, and the copyright belongs to the original author and original published source. If readers and copyright owners have any objections, please contact us and we will deal with it in a timely manner.
2. The Chinese datasheets provided on the website is a Chinese translation of the English datasheets. Its purpose is for reader's learning exchange only and do not involve commercial purposes. The translation cannot be automatically updated with the original manuscript, and there may also be improper translations. Readers are advised to use the English manuscript as a reference for more accurate information.
3. All product information provided on the website refer to solutions from manufacturers' technical support or users the contents may have differences in description, and readers are advised to take the original article as the standard.
4. If you have any questions, please contact us at marketing@iczoom.com and mark the subject with "Datasheets" .

# Small Package, High Performance, Asynchronous Boost for 10 WLED Driver

## General Description

The RT9293 is a high frequency, asynchronous boost converter. The internal MOSFET can support up to 10 White LEDs for backlighting and OLED power application, and the internal soft start function can reduce the inrush current. The device operates with 1-MHz fixed switching frequency to allow small external components and to simplify possible EMI problems. For the protection, the RT9293A provides 50V OVP and the RT9293B provides 50V/20V OVP to allow inexpensive and small-output capacitors with lower voltage ratings. The LED current is initially set with the external sense resistor  $R_{SET}$ . The RT9293 is available in the tiny package type TSOT-23-6 and WDFN-8L 2x2 packages to provide the best solution for PCB space saving and total BOM cost.

## Ordering Information

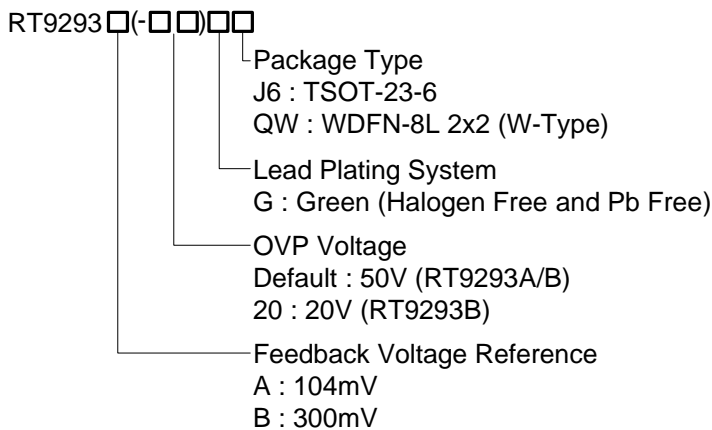

Note :

Richtek products are :

- ▶ RoHS compliant and compatible with the current requirements of IPC/JEDEC J-STD-020.
- ▶ Suitable for use in SnPb or Pb-free soldering processes.

## Marking Information

For marking information, contact our sales representative directly or through a Richtek distributor located in your area.

## Features

- VIN Operating Range : 2.5V to 5.5V
- Internal Power N-MOSFET Switch
- Wide Range for PWM Dimming (100Hz to 200kHz)
- Minimize the External Component Counts
- Internal Soft Start
- Internal Compensation
- Under Voltage Protection
- Over Voltage Protection
- Over Temperature Protection
- Small TSOT-23-6 and 8-Lead WDFN Packages
- RoHS Compliant and Halogen Free

## Applications

- Cellular Phones
- Digital Cameras
- PDAs and Smart Phones and MP3 and OLED.
- Portable Instruments

## Pin Configurations

(TOP VIEW)

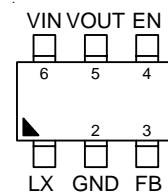

TSOT-23-6

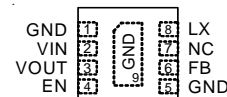

WDFN-8L 2x2

Typical Application Circuit

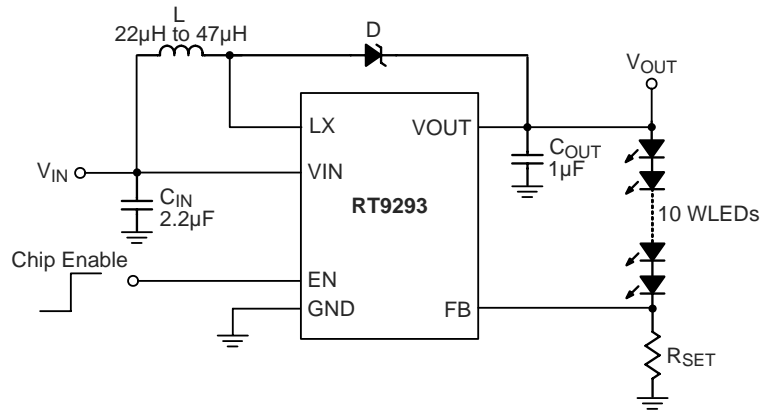

Functional Pin Description

Pin No.		Pin Name	Pin Function
RT9293□GJ6	RT9293□GQW		
1	8	LX	Switching Pin.
2	1, 5, 9 (Exposed pad)	GND	Ground Pin. The exposed pad must be soldered to a large PCB and connected to GND for maximum power dissipation.
3	6	FB	Feedback Pin, put a resistor to GND to setting the current.
4	4	EN	Chip Enable (Active High).
5	3	VOUT	Output Voltage Pin.
6	2	VIN	Input Supply.
--	7	NC	No Internal Connection.

Function Block Diagram

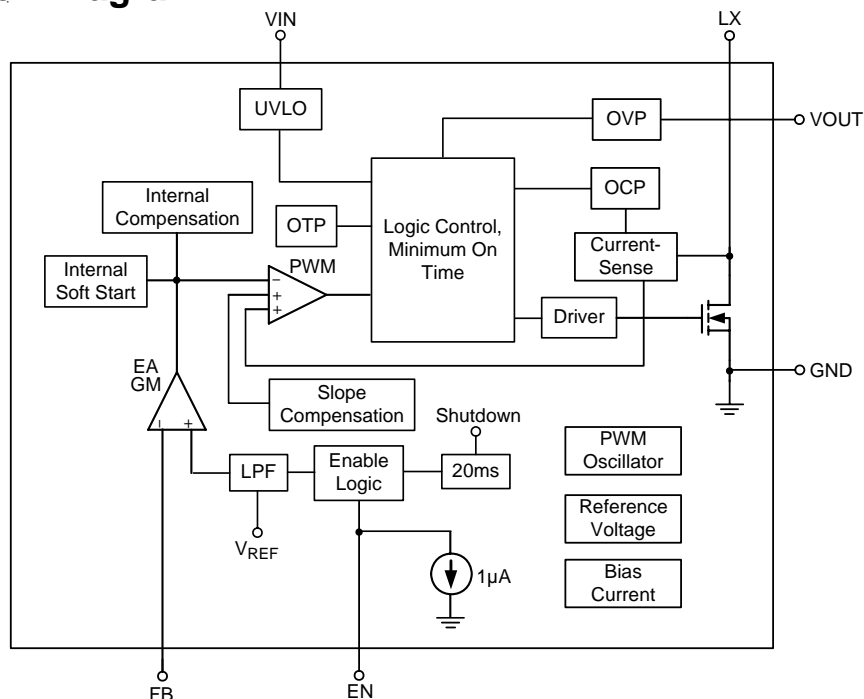

**Absolute Maximum Ratings** (Note 1)

- Supply Input Voltage,  $V_{IN}$  ----- -0.3V to 6V
- Switching Pin, LX ----- -0.3V to 50V
- VOUT ----- -0.3V to 46V
- Other Pins ----- -0.3V to 6V
- Power Dissipation,  $P_D$  @  $T_A = 25^\circ\text{C}$ 
  - TSOT-23-6 ----- 0.392W
  - WDFN-8L 2x2 ----- 0.606W
- Package Thermal Resistance (Note 2)
  - TSOT-23-6,  $\theta_{JA}$  ----- 255°C/W
  - WDFN-8L 2x2,  $\theta_{JA}$  ----- 165°C/W
  - WDFN-8L 2x2,  $\theta_{JC}$  ----- 20°C/W
- Lead Temperature (Soldering, 10 sec.) ----- 260°C
- Junction Temperature ----- 150°C
- Storage Temperature Range ----- -65°C to 150°C

**Recommended Operating Conditions** (Note 3)

- Junction Temperature Range ----- -40°C to 125°C
- Ambient Temperature Range ----- -40°C to 85°C

**Electrical Characteristics**

( $V_{IN} = 3.7\text{V}$ ,  $C_{IN} = 2.2\mu\text{F}$ ,  $C_{OUT} = 0.47\mu\text{F}$ ,  $I_{OUT} = 20\text{mA}$ ,  $L = 22\mu\text{H}$ ,  $T_A = 25^\circ\text{C}$ , unless otherwise specified)

Parameter	Symbol	Test Conditions	Min	Typ	Max	Unit
Input Voltage	$V_{IN}$		2.5	--	5.5	V
Under Voltage Lock Out	$V_{UVLO}$		2	2.2	2.45	V
UVLO Hysteresis			--	0.1	--	V
Quiescent Current	$I_Q$	FB = 1.5V, No Switching	--	400	600	$\mu\text{A}$
Supply Current	$I_{IN}$	FB = 0V, Switching	--	1	2	mA
Shutdown Current	$I_{SHDN}$	$V_{EN} < 0.4\text{V}$	--	1	4	$\mu\text{A}$
Line Regulation		$V_{IN} = 3$ to $4.3\text{V}$	--	1	--	%
Load Regulation		1mA to 20mA	--	1	--	%
Operation Frequency	$f_{OSC}$		0.75	1	1.25	MHz
Maximum Duty Cycle			90	92	--	%
Clock Rate			0.1	--	200	kHz
Feedback Reference Voltage	RT9293A	$V_{REF}$	94	104	114	mV
	RT9293B		285	300	315	
On Resistance	$R_{DS(ON)}$		--	0.7	1.2	$\Omega$

*To be continued*

Parameter		Symbol	Test Conditions	Min	Typ	Max	Unit
EN Threshold Voltage	Logic-High	$V_{IH}$		1.4	--	--	V
	Logic-Low	$V_{IL}$		--	--	0.5	
EN Sink Current		$I_{IH}$		--	1	--	$\mu A$
EN Hysteresis				--	0.1	--	V
Over-Voltage Threshold	OVP = 50V	$V_{OVP}$		42	46	50	V
	RT9293B-20			16	17.5	20	
Over-Current Threshold		$I_{OCP}$		1	1.2	--	A
OTP		$T_{OTP}$		--	160	--	$^{\circ}C$
OTP Hysteresis				--	30	--	$^{\circ}C$
Shutdown Delay		$T_{SHDN}$		--	20	--	ms

**Note 1.** Stresses listed as the above "Absolute Maximum Ratings" may cause permanent damage to the device. These are for stress ratings. Functional operation of the device at these or any other conditions beyond those indicated in the operational sections of the specifications is not implied. Exposure to absolute maximum rating conditions for extended periods may remain possibility to affect device reliability.

**Note 2.**  $\theta_{JA}$  is measured in the natural convection at  $T_A = 25^{\circ}C$  on a low effective single layer thermal conductivity test board of JEDEC 51-3 thermal measurement standard. The case point of  $\theta_{JC}$  is on the expose pad for the WDFN package.

**Note 3.** The device is not guaranteed to function outside its operating conditions.

Typical Operating Characteristics

Efficiency vs. Output Current

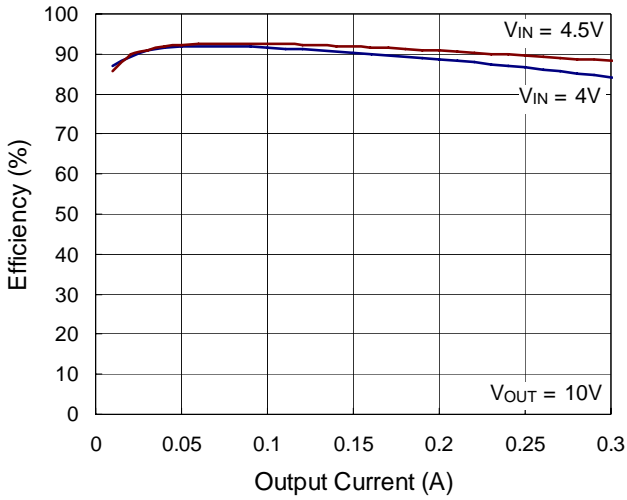

Efficiency vs. Input Voltage

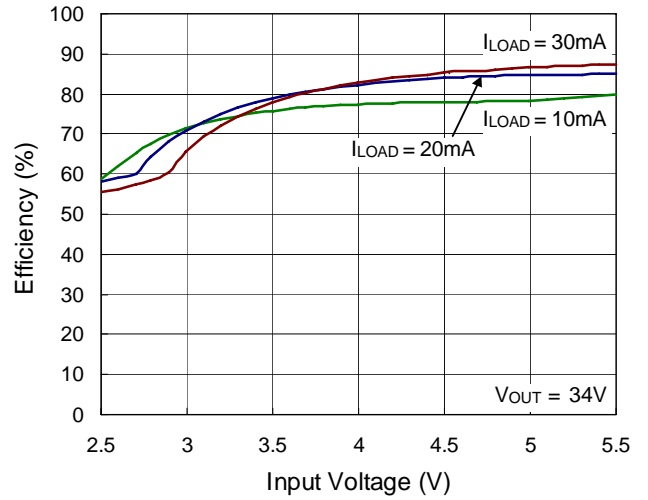

Output Voltage vs. Output Current

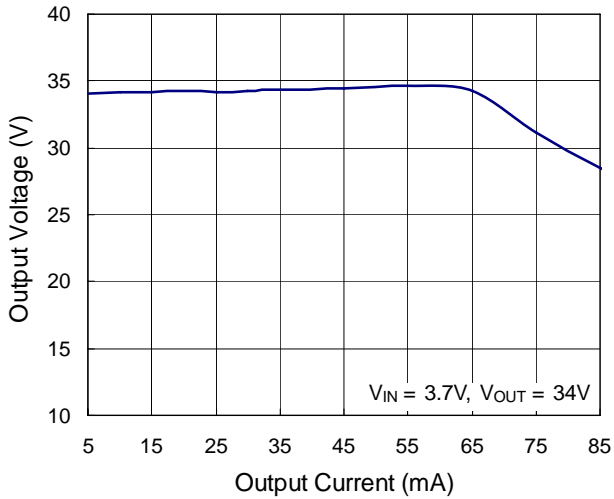

Quiescent Current vs. Input Voltage

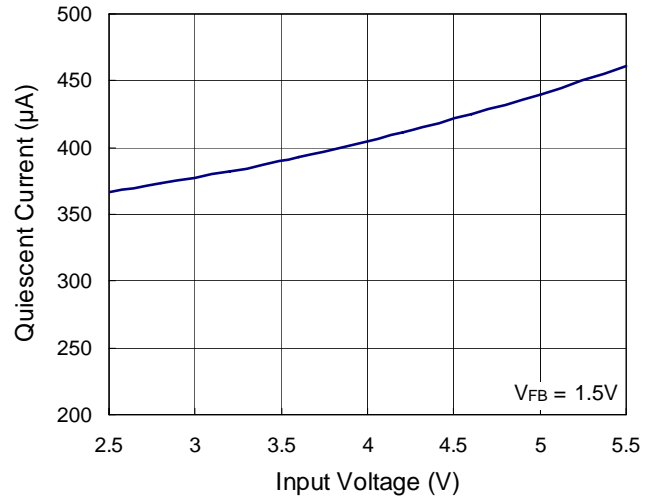

Frequency vs. Input Voltage

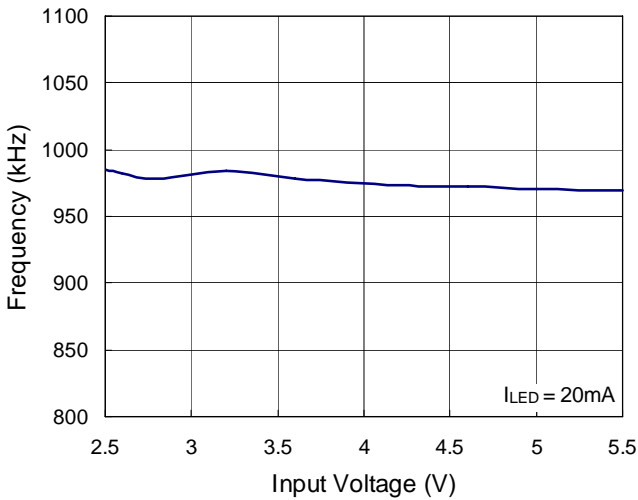

Frequency vs. Temperature

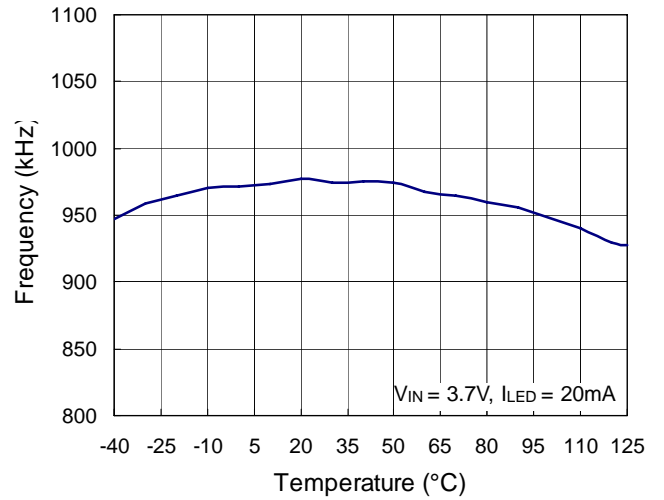

Reference Voltage vs. Input Voltage

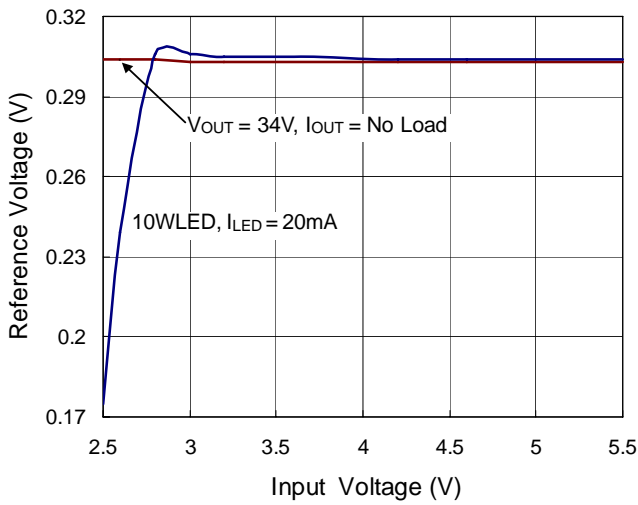

Reference Voltage vs. Temperature

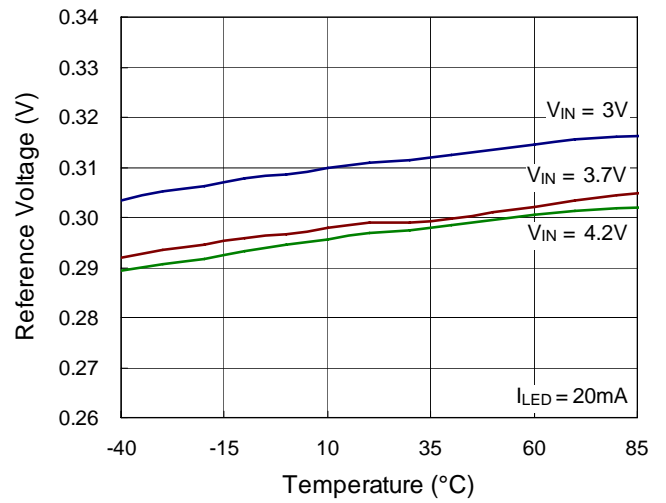

Reference Voltage vs. Output Current

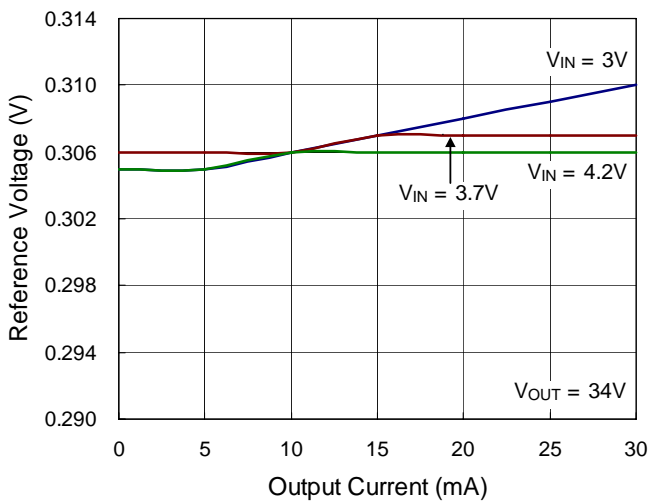

Enable Threshold vs. Input Voltage

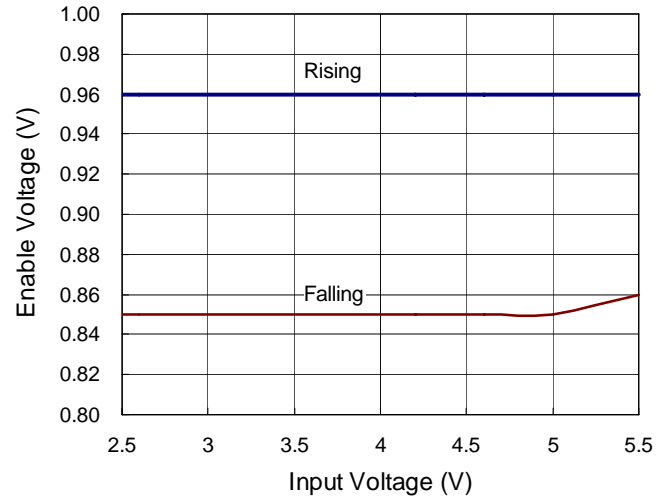

LED Current vs. Duty

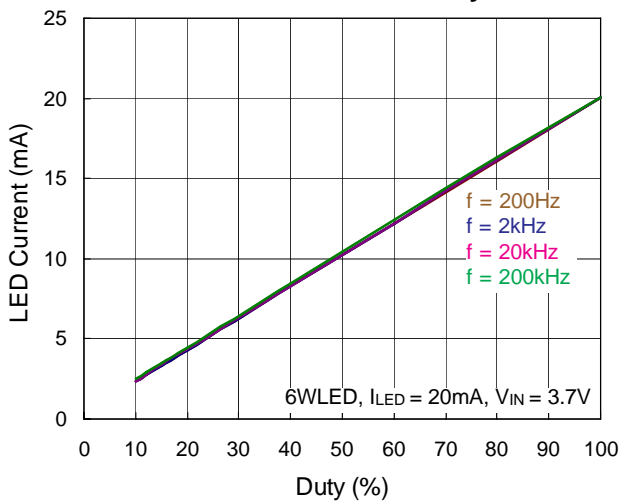

Power On from EN

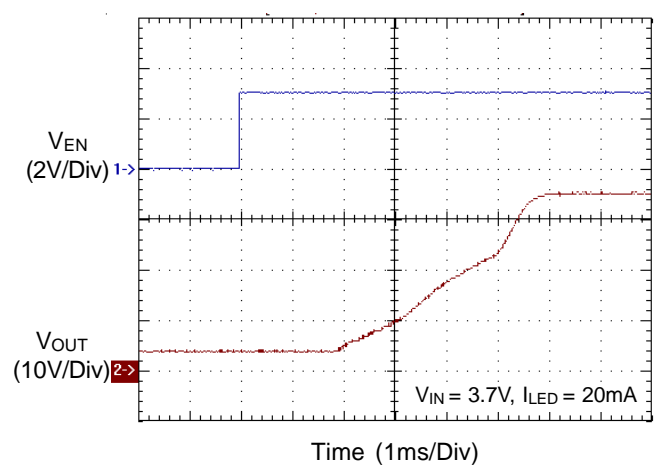

Power Off from EN

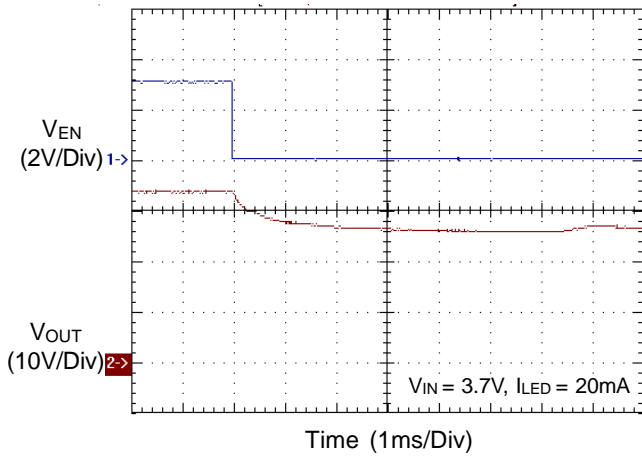

Ripple Voltage

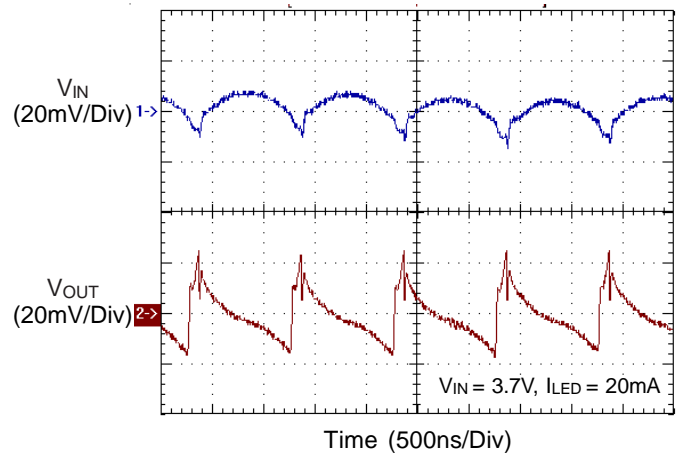

PWM Dimming from EN

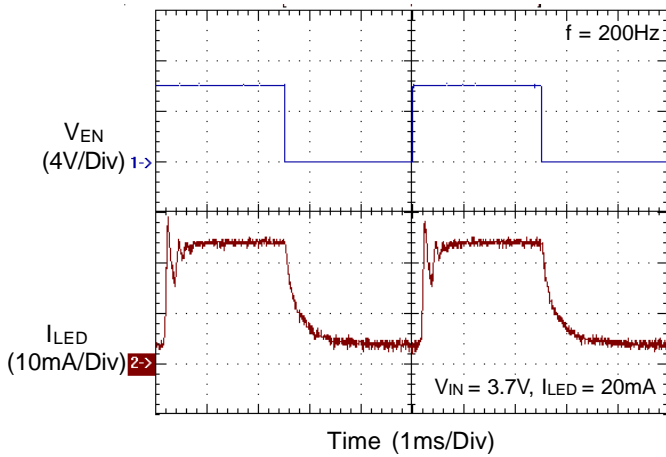

PWM Dimming from EN

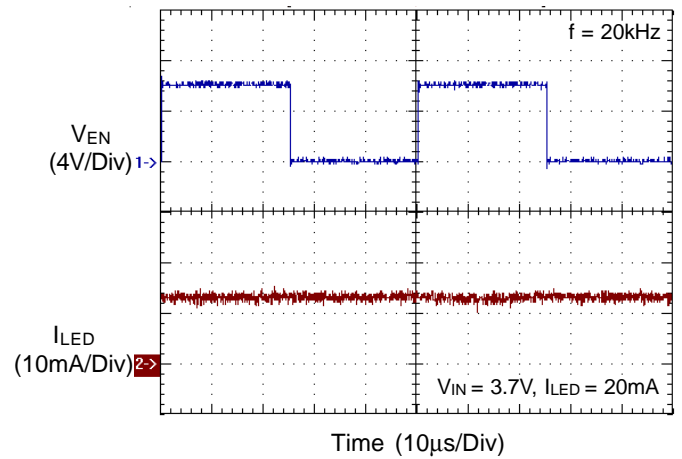



## Applications Information

### LED Current Setting

The loop of Boost structure will keep the FB pin voltage equal to the reference voltage  $V_{REF}$ . Therefore, when  $R_{SET}$  connects FB pin and GND, the current flows from  $V_{OUT}$  through LED and  $R_{SET}$  to GND will be decided by the current on  $R_{SET}$ , which is equal to following equation :

$$I_{LED} = \frac{V_{REF}}{R_{SET}}$$

### Dimming Control

#### a. Using a PWM Signal to EN Pin

For the brightness dimming control of the RT9293, the IC provides typically 300mV feedback voltage when the EN pin is pulled constantly high. However, EN pin allows a PWM signal to reduce this regulation voltage by changing the PWM duty cycle to achieve LED brightness dimming control. The relationship between the duty cycle and FB voltage can be calculated as following equation :

$$V_{FB} = \text{Duty} \times 300\text{mV}$$

Where

Duty = duty cycle of the PWM signal

300mV = internal reference voltage

As shown in Figure 1, the duty cycle of the PWM signal is used to cut the internal 300mV reference voltage. An internal low pass filter is used to filter the pulse signal. And then the reference voltage can be made by connecting the output of the filter to the error amplifier for the FB pin voltage regulation.

However, the internal low pass filter 3db frequency is 500Hz. When the dimming frequency is lower than 500Hz,  $V_A$  is also a PWM signal and the LED current is controlled directly by this signal. When the frequency is higher than 500Hz, PWM is filtered by the internal low pass filter and the  $V_A$  approach a DC signal. And the LED current is a DC current which eliminate the audio noise. Two figures of PWM Dimming from EN are shown in Typical Operating Characteristics section and the PWM dimming frequency is 200Hz and 20kHz respectively.

But there is an offset in error amplifier which will cause the  $V_A$  variation. In low PWM duty signal situation, the

filtered reference voltage is low and the offset can cause bigger variation of the output current. So the RT9293A is not recommend to be dimming by the EN pin. For the RT9293B, the minimum duty vs frequency is listed in following table.

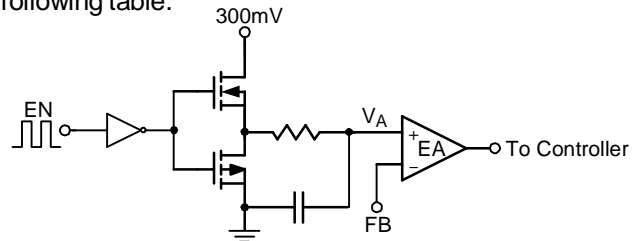

Figure 1. Block Diagram of Programmable FB Voltage Using PWM Signal

	Duty Minimum
Dimming frequency < 500Hz	4%
Dimming frequency > 500Hz	10%

#### b. Using a DC Voltage

Using a variable DC voltage to adjust the brightness is a popular method in some applications. The dimming control using a DC voltage circuit is shown in Figure 2. As the DC voltage increases, the current flows through  $R_3$  increasingly and the voltage drop on  $R_3$  increase, i.e. the LED current decreases. For example, if the  $V_{DC}$  range is from 0V to 2.8V and assume the RT9293 is selected which  $V_{REF}$  is equal to 0.3V, the selection of resistors in Figure 2 sets the LED current from 21mA to 0mA. The LED current can be calculated by the following equation.

$$I_{LED} = \frac{V_{REF} - \frac{R_3 \times (V_{DC} - V_{REF})}{R_4}}{R_{SET}}$$

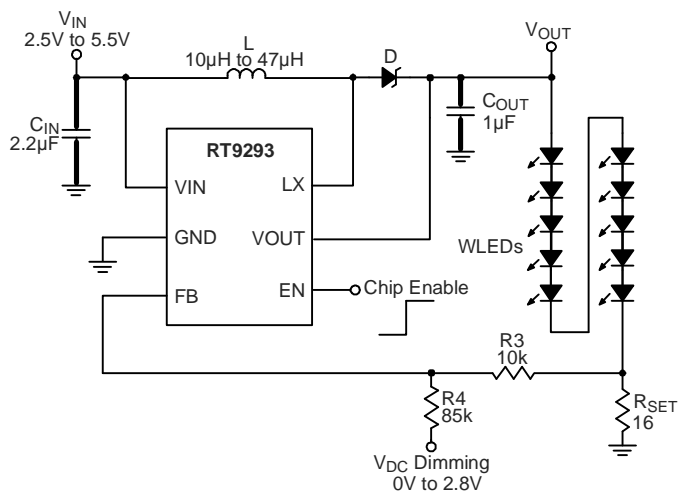

Figure 2. Dimming Control Using a DC Voltage

**c. Using a Filtered PWM signal**

Another common application is using a filtered PWM signal as an adjustable DC voltage for LED dimming control. A filtered PWM signal acts as the DC voltage to regulate the output current. The recommended application circuit is shown as Figure 3. In this circuit, the output ripple depends on the frequency of PWM signal. For smaller output voltage ripple (<100mV), the recommended frequency of 2.8V PWM signal should be above 2kHz. To fix the frequency of PWM signal and change the duty cycle of PWM signal can get different output current. The LED current can be calculated by the following equation :

$$I_{LED} = \frac{V_{REF} - \frac{R3 \times (V_{PWM} \times Duty - V_{REF})}{R4 + R_{DC}}}{R_{SET}}$$

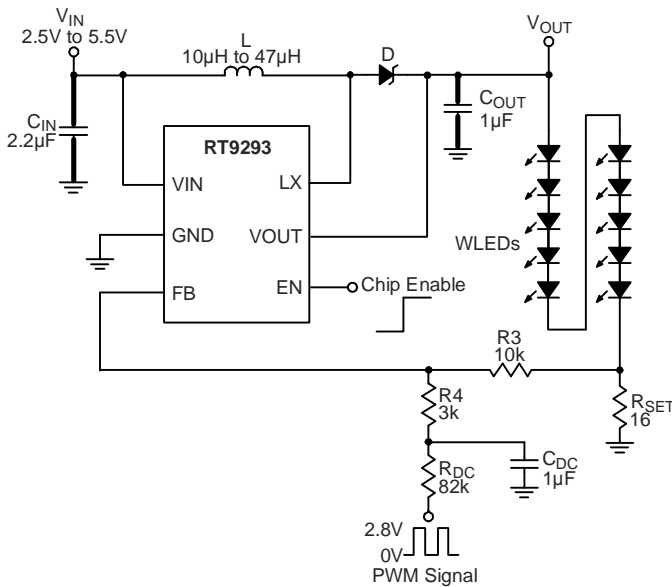

Figure 3. Dimming Control Using a Filtered PWM Signal

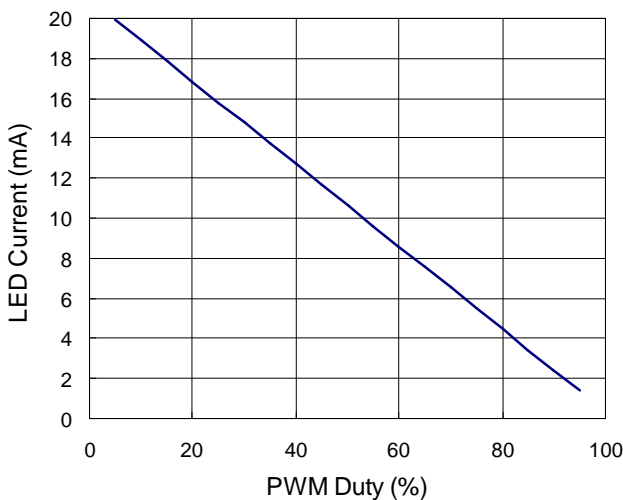

Figure 4. PWM Duty Cycle vs. LED Current

By the above equation and the application circuit shown in Figure 3, and assume the RT9293 is selected which  $V_{REF}$  is equal to 0.3V. Figure 4 shows the relationship between the LED current and PWM duty cycle. For example, when the PWM duty is equal to 60%, the LED current will be equal to 8.6mA. When the PWM duty is equal to 40%, the LED current will be equal to 12.7mA.

**Constant Output Voltage Control**

The output voltage of the R9293 can be adjusted by the divider circuit on the FB pin. Figure 5 shows the application circuit for the constant output voltage. The output voltage can be calculated by the following equations :

$$V_{OUT} = V_{REF} \times \frac{R1 + R2}{R2} ; R2 > 10k$$

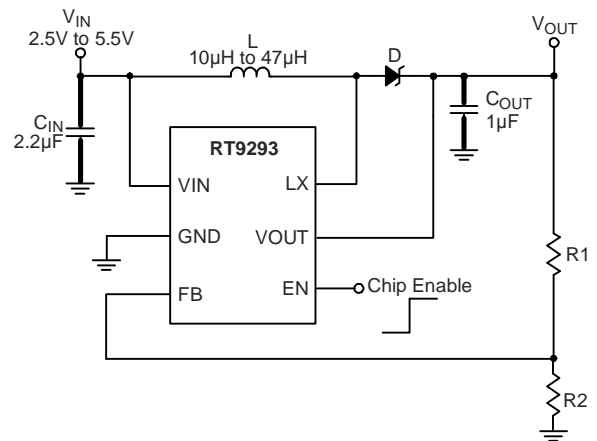

Figure 5. Constant Output Voltage Application

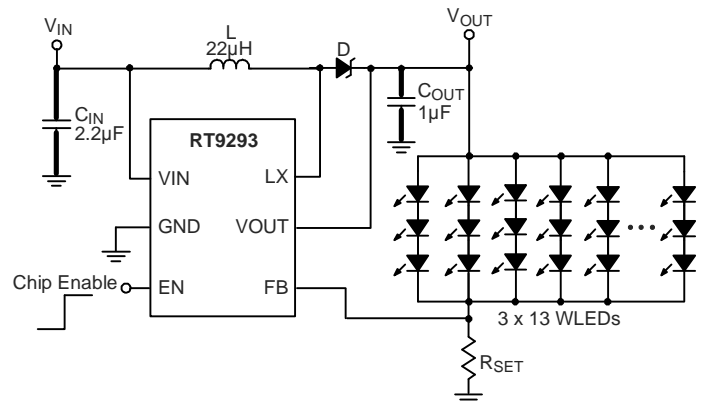

Figure 6. Application for Driving 3 X 13 WLEDs

### Application for Driving 3 x 13 WLEDs

The RT9293 can drive different WLEDs topology. For example, the Figure 6 shows the 3x13 WLEDs and total current is equal to 260mA. The total WLEDs current can be set by the  $R_{SET}$  which is equal to following equation.

$$I_{Total} = \frac{V_{REF}}{R_{SET}}$$

### Power Sequence

In order to assure the normal soft start function for suppressing the inrush current the input voltage should be ready before EN pulls high.

### Soft-Start

The function of soft-start is made for suppressing the inrush current to an acceptable value at the beginning of power-on. The RT9293 provides a built-in soft-start function by clamping the output voltage of error amplifier so that the duty cycle of the PWM will be increased gradually in the soft-start period.

### Current Limiting

The current flow through inductor as charging period is detected by a current sensing circuit. As the value comes across the current limiting threshold, the N-MOSFET will be turned off so that the inductor will be forced to leave charging stage and enter discharging stage. Therefore, the inductor current will not increase over the current limiting threshold.

### OVP/UVLO/OTP

The Over Voltage Protection is detected by a junction breakdown detecting circuit. Once  $V_{OUT}$  goes over the detecting voltage, LX pin stops switching and the power N-MOSFET will be turned off. Then, the  $V_{OUT}$  will be clamped to be near  $V_{OVP}$ . As the output voltage is higher than a specified value or input voltage is lower than a specified value, the chip will enter protection mode to prevent abnormal function. As the die temperature is higher than 160°C, the chip also will enter protection mode. The power MOSFET will be turned off during protection mode to prevent abnormal operation.

### Inductor Selection

The recommended value of inductor for 10 WLEDs applications is from 10μH to 47μH. Small size and better efficiency are the major concerns for portable devices, such as the RT9293 used for mobile phone. The inductor should have low core loss at 1MHz and low DCR for better efficiency. The inductor saturation current rating should be considered to cover the inductor peak current.

### Capacitor Selection

Input ceramic capacitor of 2.2μF and output ceramic capacitor of 1μF are recommended for the RT9293 applications for driving 10 series WLEDs. For better voltage filtering, ceramic capacitors with low ESR are recommended. X5R and X7R types are suitable because of their wider voltage and temperature ranges.

### Thermal Considerations

For continuous operation, do not exceed absolute maximum operation junction temperature. The maximum power dissipation depends on the thermal resistance of IC package, PCB layout, the rate of surroundings airflow and temperature difference between junction to ambient. The maximum power dissipation can be calculated by following formula :

$$P_{D(MAX)} = (T_{J(MAX)} - T_A) / \theta_{JA}$$

Where  $T_{J(MAX)}$  is the maximum operation junction temperature,  $T_A$  is the ambient temperature and the  $\theta_{JA}$  is the junction to ambient thermal resistance.

For the recommended operating conditions specification of RT9293, the maximum junction temperature of the die is 125°C. The junction to ambient thermal resistance  $\theta_{JA}$  is layout dependent. The junction to ambient thermal resistance for TSOT-23-6 package is 255°C/W and for WDFN-8L 2x2 package is 165°C/W on the standard JEDEC 51-3 single layer thermal test board. The maximum power dissipation at  $T_A = 25^\circ\text{C}$  can be calculated by following formula :

$$P_{D(MAX)} = (125^\circ\text{C} - 25^\circ\text{C}) / (165^\circ\text{C}/\text{W}) = 0.606\text{W for WDFN-8L 2x2 packages}$$

$$P_{D(MAX)} = (125^\circ\text{C} - 25^\circ\text{C}) / (255^\circ\text{C}/\text{W}) = 0.392\text{W for TSOT-23-6 packages}$$

The maximum power dissipation depends on operating ambient temperature for fixed  $T_{J(MAX)}$  and thermal resistance  $\theta_{JA}$ . For RT9293 packages, the Figure 7 of derating curves allows the designer to see the effect of rising ambient temperature on the maximum power allowed.

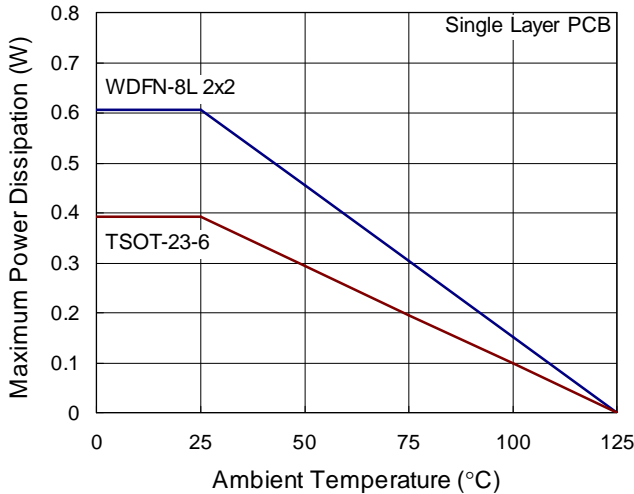

Figure 7. Derating Curves for RT9293 Packages

**Layout Consideration**

For best performance of the RT9293, the following guidelines must be strictly followed.

- } Input and Output capacitors should be placed close to the IC and connected to ground plane to reduce noise coupling.
- } The GND and Exposed Pad should be connected to a strong ground plane for heat sinking and noise protection.
- } Keep the main current traces as possible as short and wide.
- } LX node of DC-DC converter is with high frequency voltage swing. It should be kept at a small area.
- } Place the feedback components as close as possible to the IC and keep away from the noisy devices.

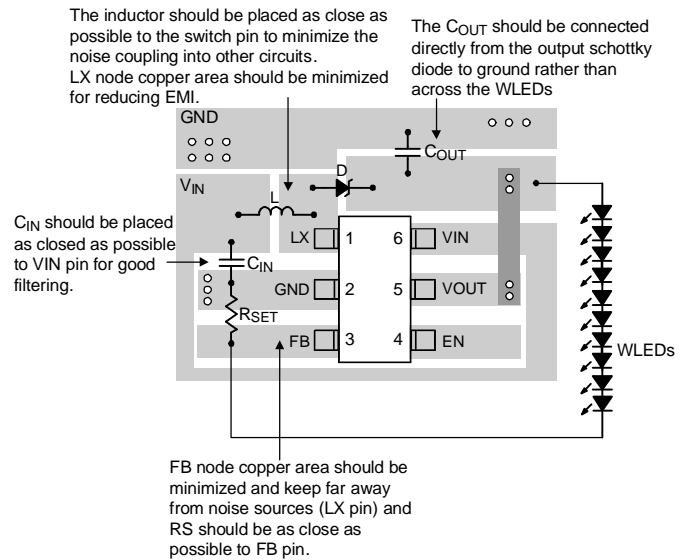
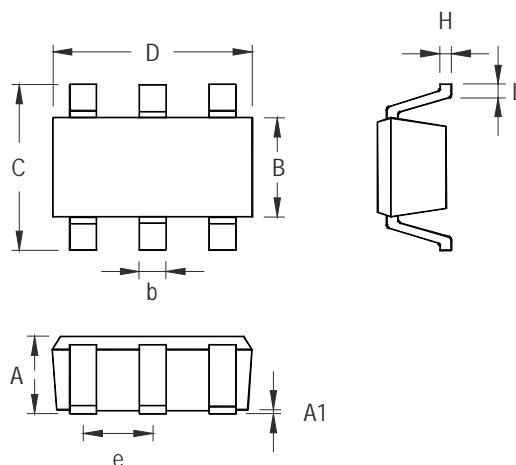

Figure 8. The Layout Consideration of the RT9293

**Table 1. Recommended Components for Typical Application Circuit**

Reference	Qty	Part Number	Description	Manufacture
D	1	SR26	Schottky Diode	PANJIT
C <sub>IN</sub>	1	EMK107BJ225MA-T	Capacitor, Ceramic, 2.2μF/16V X5R	Taiyo Yuden
C <sub>OUT</sub>	1	GMK107BJ105KA	Capacitor, Ceramic, 1μF/50V X5R	Taiyo Yuden
R <sub>SET</sub>	1	RC0603FR	Resistor 15Ω, 1%	YAGEO
L	1	NR4018T220M	Inductor, 22μH	Taiyo Yuden

## Outline Dimension



Symbol	Dimensions In Millimeters		Dimensions In Inches	
	Min	Max	Min	Max
A	0.700	1.000	0.028	0.039
A1	0.000	0.100	0.000	0.004
B	1.397	1.803	0.055	0.071
b	0.300	0.559	0.012	0.022
C	2.591	3.000	0.102	0.118
D	2.692	3.099	0.106	0.122
e	0.838	1.041	0.033	0.041
H	0.080	0.254	0.003	0.010
L	0.300	0.610	0.012	0.024

**TSOT-23-6 Surface Mount Package**

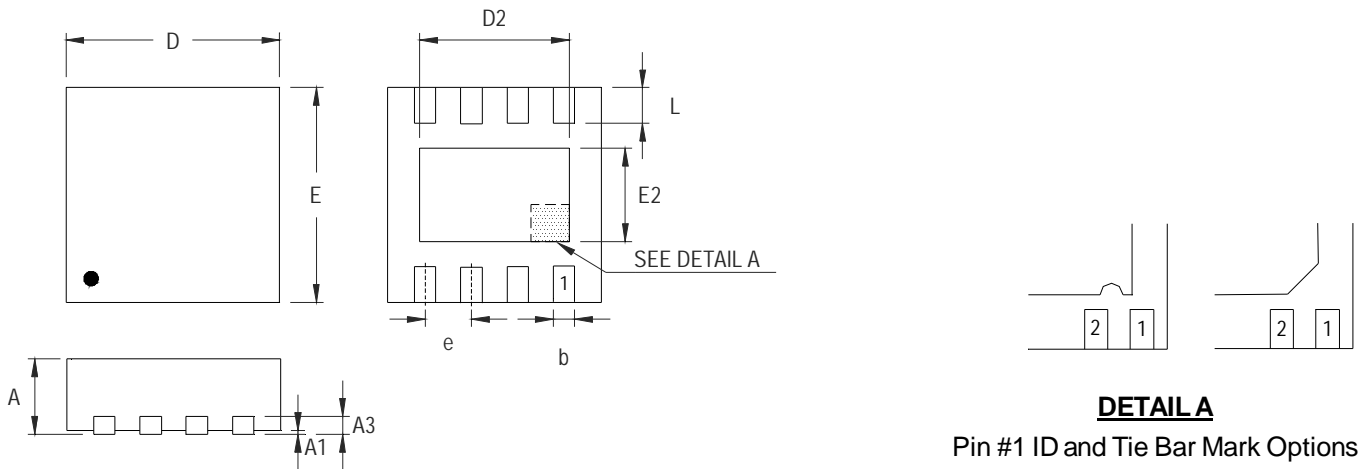

Note : The configuration of the Pin #1 identifier is optional, but must be located within the zone indicated.

Symbol	Dimensions In Millimeters		Dimensions In Inches	
	Min	Max	Min	Max
A	0.700	0.800	0.028	0.031
A1	0.000	0.050	0.000	0.002
A3	0.175	0.250	0.007	0.010
b	0.200	0.300	0.008	0.012
D	1.950	2.050	0.077	0.081
D2	1.000	1.250	0.039	0.049
E	1.950	2.050	0.077	0.081
E2	0.400	0.650	0.016	0.026
e	0.500		0.020	
L	0.300	0.400	0.012	0.016

**W-Type 8L DFN 2x2 Package**

**Richtek Technology Corporation**

Headquarter  
5F, No. 20, Taiyuen Street, Chupei City  
Hsinchu, Taiwan, R.O.C.  
Tel: (8863)5526789 Fax: (8863)5526611

**Richtek Technology Corporation**

Taipei Office (Marketing)  
5F, No. 95, Minchiuan Road, Hsintien City  
Taipei County, Taiwan, R.O.C.  
Tel: (8862)86672399 Fax: (8862)86672377  
Email: marketing@richtek.com

Information that is provided by Richtek Technology Corporation is believed to be accurate and reliable. Richtek reserves the right to make any change in circuit design, specification or other related things if necessary without notice at any time. No third party intellectual property infringement of the applications should be guaranteed by users when integrating Richtek products into any application. No legal responsibility for any said applications is assumed by Richtek.