

阅读申明

- 1.本站收集的数据手册和产品资料都来自互联网，版权归原作者所有。如读者和版权方有任何异议请及时告之，我们将妥善解决。
- 2.本站提供的中文数据手册是英文数据手册的中文翻译，其目的是协助用户阅读，该译文无法自动跟随原稿更新，同时也可能存在翻译上的不当。建议读者以英文原稿为参考以便获得更精准的信息。
- 3.本站提供的产品资料，来自厂商的技术支持或者使用者的心得体会等，其内容可能存在描述上的差异，建议读者做出适当判断。
- 4.如需与我们联系，请发邮件到marketing@iczoom.com，主题请标有“数据手册”字样。

Read Statement

1. The datasheets and other product information on the site are all from network reference or other public materials, and the copyright belongs to the original author and original published source. If readers and copyright owners have any objections, please contact us and we will deal with it in a timely manner.
2. The Chinese datasheets provided on the website is a Chinese translation of the English datasheets. Its purpose is for reader's learning exchange only and do not involve commercial purposes. The translation cannot be automatically updated with the original manuscript, and there may also be improper translations. Readers are advised to use the English manuscript as a reference for more accurate information.
3. All product information provided on the website refer to solutions from manufacturers' technical support or users the contents may have differences in description, and readers are advised to take the original article as the standard.
4. If you have any questions, please contact us at marketing@iczoom.com and mark the subject with "Datasheets" .

Stepping Motor Drive IC AN8495SB

Overview

AN8495SB is a stepping-motor-driving IC, created by using a D-MOS process, and provides a maximum output of 30V at 1.5A. By the PWM drive and 2-bit constant-current-chopping-drive method, the winding 1-2 phase drive is possible.

Feature

- 4-phase input (W1-2 phase excitation)
- 2-bit current level switching.
- Built-in noise canceller.
- Built-in phase-change thru-current protection function.
- Built-in flywheel diode

Applications

- Printer , FAX ,PPC

Recommended Operating Range

Operating supply voltage range	VCC	4.75V to 5.25V
	VM	18.0V to 28.0V

Electrical Characteristics (Ta=25°C±2°C, Vcc=5.0V, VM=24V)

Parameter	Symbol	Condition	min	typ	max	unit
Power block						
Output saturation voltage H	VOH	I = -1.0A	VM-0.75	VM-0.5	-	V
Output saturation voltage L	VOL	I = 1.0A	-	0.65	0.98	V
Flywheel diode forward voltage	VDI	I = 1.0A	0.5	1.0	1.5	V
Control block						
PWM frequency	fPWM		50.2	67	83.8	kHz
Comparator threshold H(100%)	VTH	IN0=IN1=0V, IN2=IN3=0V	0.479	0.503	0.528	V
Comparator threshold C(67%)	VTC	IN0=5V, IN1=0V, IN2=5V, IN3=0V	0.305	0.330	0.356	V
Comparator threshold L(33%)	VTL	IN0=0V, IN1=5V, IN2=0V, IN3=5V	0.151	0.167	0.185	V

The products and specification are subject to change without any notice. Please ask for the latest Product Standards to guarantee the satisfaction of your product requirements.

Semiconductor Company, Matsushita Electric Industrial Co., Ltd.

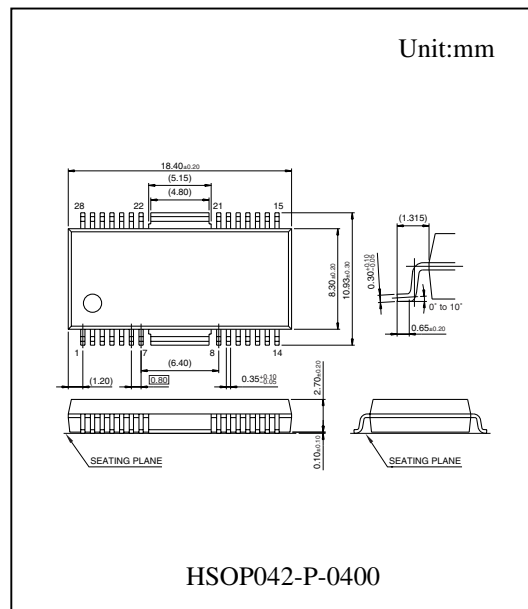

■ Block Diagram

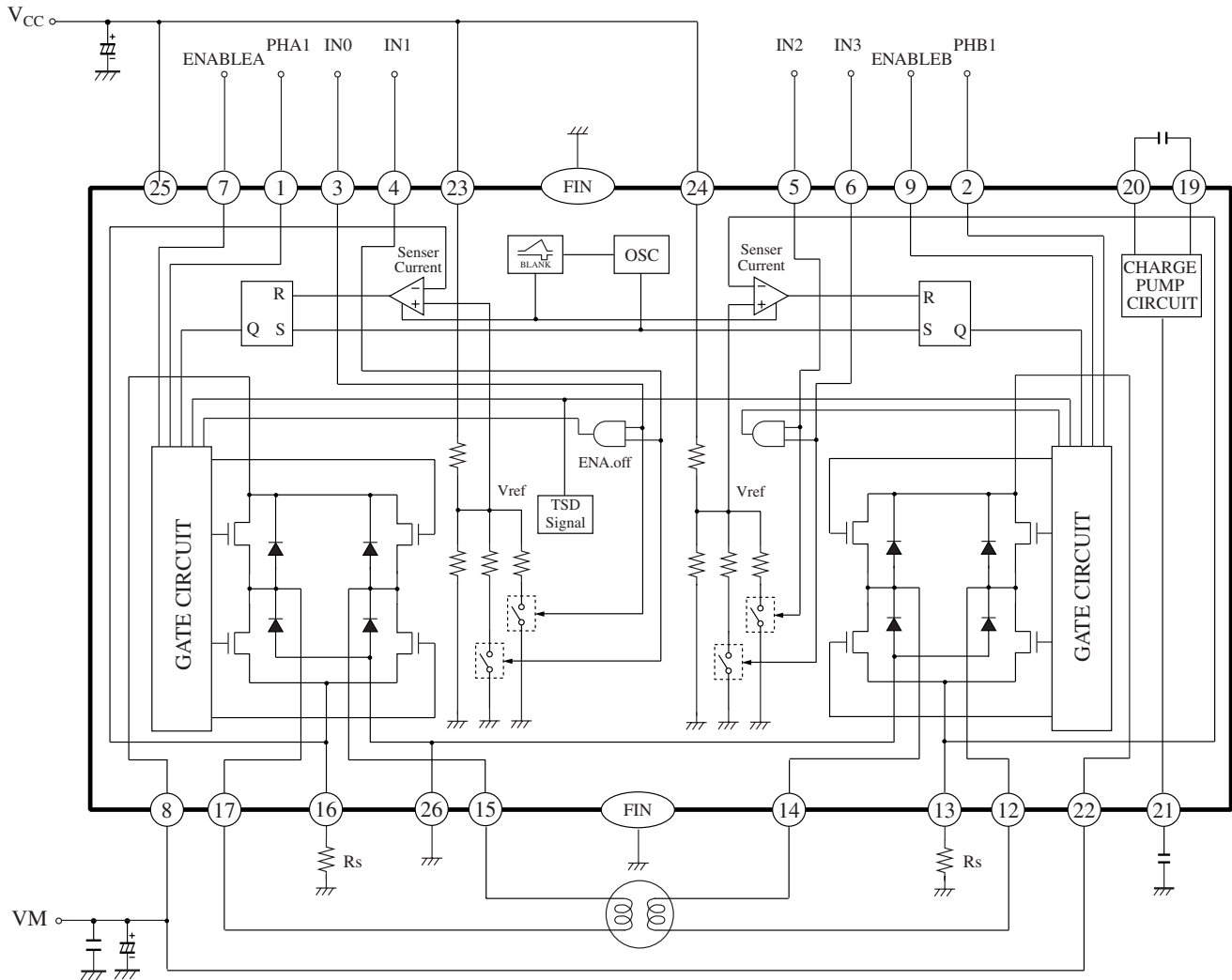

* A voltage is applied externally to Terminals PHA1, PHB1, IN0 to 3, ENABLEA, ENABLEB, VREFA and VREFV, and may cause an overcurrent. To protect the device from overcurrent, insert an overcurrent protective resistor (1K Ω or over).

■ Pin Descriptions

Pin No.	Symbol	Function	Pin No.	Symbol	Function
1	PHA1	A phase changeover terminal	16	RCSA	A phase current detector
2	PHB1	B phase changeover terminal	17	AOUT1	Motor drive A phase output 1
3	IN0	A phase output torque control 1	18	N.C	-
4	IN1	A phase output torque control 2	19	BC1	Capacitor for charge pump circuit 1
5	IN2	B phase output torque control 1	20	BC2	Capacitor for charge pump circuit 2
6	IN3	B phase output torque control 2	21	VPUMP	Charge pump circuit output
7	ENABLEA	A phase start/stop signal input	22	VM2	Supply terminal for Motor 2
8	VM1	Supply terminal for Motor 1	23	VREFA	A phase torque ref. voltage input
9	ENABLEB	B phase start/stop signal input	24	VREFB	B phase torque ref. voltage input
10	N.C	-	25	VCC	Supply terminal
11	N.C	-	26	GND	Signal GND
12	BOUT2	Motor drive B phase output 2	27	N.C	-
13	RCSB	B phase current detector	28	N.C	-
14	BOUT1	Motor drive B phase output 1	FIN	GND	Signal GND
15	AOUT2	Motor drive A phase output 2			