

阅读申明

- 1.本站收集的数据手册和产品资料都来自互联网，版权归原作者所有。如读者和版权方有任何异议请及时告之，我们将妥善解决。
- 2.本站提供的中文数据手册是英文数据手册的中文翻译，其目的是协助用户阅读，该译文无法自动跟随原稿更新，同时也可能存在翻译上的不当。建议读者以英文原稿为参考以便获得更精准的信息。
- 3.本站提供的产品资料，来自厂商的技术支持或者使用者的心得体会等，其内容可能存在描述上的差异，建议读者做出适当判断。
- 4.如需与我们联系，请发邮件到marketing@iczoom.com，主题请标有“数据手册”字样。

Read Statement

1. The datasheets and other product information on the site are all from network reference or other public materials, and the copyright belongs to the original author and original published source. If readers and copyright owners have any objections, please contact us and we will deal with it in a timely manner.
2. The Chinese datasheets provided on the website is a Chinese translation of the English datasheets. Its purpose is for reader's learning exchange only and do not involve commercial purposes. The translation cannot be automatically updated with the original manuscript, and there may also be improper translations. Readers are advised to use the English manuscript as a reference for more accurate information.
3. All product information provided on the website refer to solutions from manufacturers' technical support or users the contents may have differences in description, and readers are advised to take the original article as the standard.
4. If you have any questions, please contact us at marketing@iczoom.com and mark the subject with "Datasheets" .



LB1860,1860M,1861,1861M

Variable Speed Fan Motor Driver

An ON Semiconductor Company

Overview

The LB1860 series ICs are drivers for two-phase unipolar drive DC brushless fan motors. They have functions such as driving, lock protection, restart and speed control.

Features and Functions

- Two-speed mode select function requiring less external component additions: Full speed and Low speed. Or, thermistor-controlled continuous variable-speed function according to ambient operation temperatures.
→ Motor starts rotating at a low speed.
- Motor lock protection and automatic return circuit built in
- Output transistors: Output current $I_O = 1.5\text{ A}$, output circuit protection Zener diodes (LB1860: M-Vz = 57 V/ LB1861: M-Vz = 32 V)
→ Enables low-level noise protection with chip capacitor.
- Built-in thermal shutdown circuit
- Built-in rotation detect function
(Drive mode: "L", Stop mode: "H")
- The LB1860 series can be operated from either 12 V or 24 V power supply by changing an external resistor.
(Strong protection against power supply surge)
- Connectable direct to a Hall element

Package Dimensions

unit: mm

3098B-DIP10S

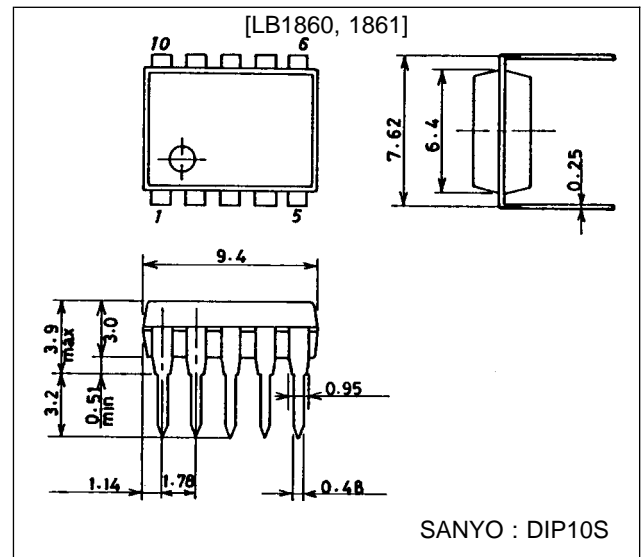

unit: mm

3111-MFP14S

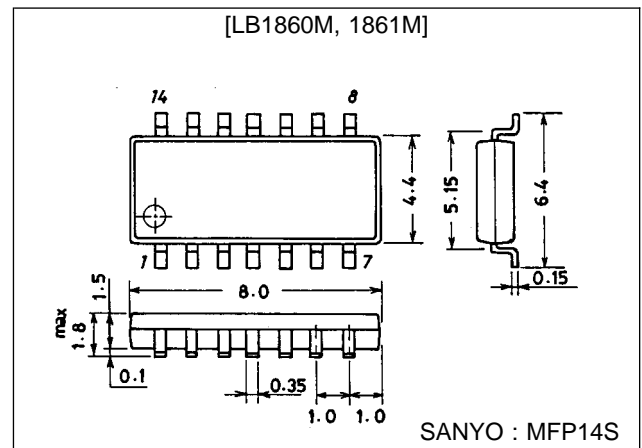

Specifications

Absolute Maximum Ratings at Ta = 25 °C, (): LB1860M, LB1861M

Parameter	Symbol	Conditions	Ratings	Unit
Maximum input current	I _{CC} max	t ≤ 20 ms	200	mA
Output supply voltage	V _{OUT}		Internal	V
Output current	I _{OUT}		1.5	A
RD flow-in current	I _{RD}		10	mA
RD supply voltage	V _{RD}		50	V
Allowable power dissipation	Pd1 max		1.1	W
	Pd2 max	Mounted on 20 × 15 × 1.5 mm glass epoxy board	(0.8)	W
Operating temperature	Topr		-30 to +80	°C
Storage temperature	Tstg		-55 to +125	°C

Allowable Operating Ranges at Ta = 25 °C

Parameter	Symbol	Conditions	Ratings	Unit
Input current range	I _{CC}		6.0 to 50	mA
Common-mode input voltage range	V _{ICM}		0 to V _{IN} - 1.5	V

Electrical Characteristics at Ta = 25 °C, I_{CC} = 10 mA

Parameter	Symbol	Conditions	min	typ	max	Unit
Output limiting voltage	V _{OLM1}	LB1860, 1860M: I _O = 0.1 A	54	57	60	V
		LB1861, 1861M: I _O = 0.1 A	30	32	34	V
Output saturation voltage	V _{O sat1}	I _O = 0.5 A		0.95	1.2	V
	V _{O sat2}	I _O = 1.0 A		1.15	1.5	V
	V _{O sat3}	I _O = 1.5 A		1.4	2.0	V
Input voltage	V _{IN}	I _{CC} = 7.0 mA	6.4	6.7	7.0	V
Amp input offset voltage	V _{OFF}		-7.0	0	7.0	mV
Amp input bias current	I _{BA}		-250			nA
RD output saturation voltage	V _{RD} (sat)	I _{RD} = 5 mA		0.15	0.3	V
C flow-out current	I _{C1}	C = GND	2.7	3.9	5.0	μA
C discharge current	I _{C2}	C = V _{IN}	0.35	0.50	0.65	μA
Comparator input threshold voltage	V _{TH1}		0.77	0.8 V _{IN}	0.83	V
	V _{TH2}		0.44	0.47 V _{IN}	0.50	V
Ct discharge voltage	V _{ct}		0.18	0.2 V _{IN}	0.22	V
Rt input current	I _{RT}	V _{RT} = GND	-440	-350	-240	μA
Rt comparator voltage	V _{RT}	R _T = OPEN	0.59	0.62 V _{IN}	0.65	V
Thermal protection circuit operating voltage	TSD	Design target		180		°C
Thermal protection circuit hysteresis	ΔTSD	Design target		40		°C

Pin Assignments

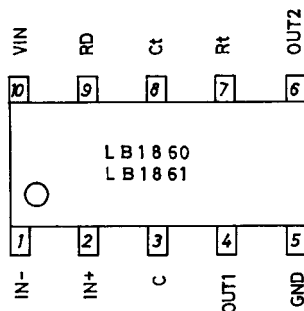

Top view

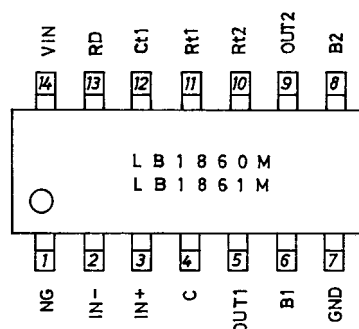

Top view

Block Diagram and Application Circuit

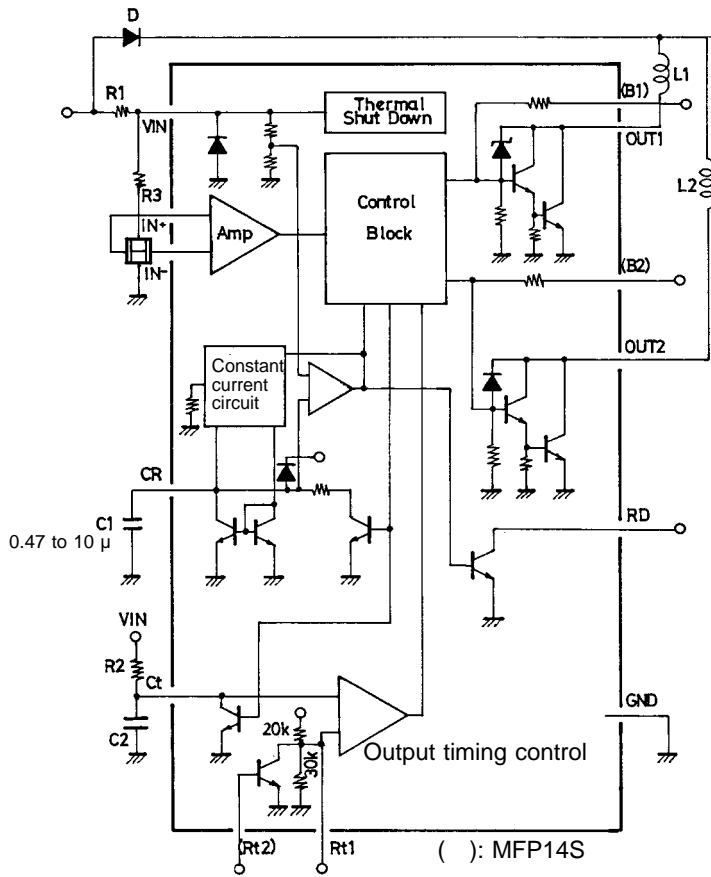

Unit (resistance: Ω, capacitance: F)

Figure 1

Truth Table

(): LB1860M, 1861M

IN ⁺	IN ⁻	Ct	Rt1	Rt2	CR	OUT1	OUT2	RD	Mode
H	L	H	L	—	L	H	L	L	Full speed
L	H	H	L	—	L	L	H	L	Full speed
(H)	(L)	—	—	(H)	(L)	(H)	(L)	(L)	(Full speed)
(L)	(H)	—	—	(H)	(L)	(L)	(H)	(L)	(Full speed)
—	—	L	H	L	L	H	H	L	Low speed
—	—	—	—	—	H	H	H	H	Lock protection

Designer's Notes

- (1) Variable-speed circuit (Rt and Ct pins) — Refer to the application circuit diagram
- The time constant gained by external components C2 and R2 is used to set the length of an 'off' operation time period after phase switching. This means that the variable-speed operations can be performed by changing the 'on' operation time of each phase through the duty control.
- The sawtooth waveform signals are generated by the C2-R2 time constant. The voltage of this signal (Ct pin voltage) increases from 1.3 V to 4.0 V (Vct) at each phase switching. That is, during this period, the driver becomes inactive (t_{off}), in which output circuit is turned off.
- If V_{CC} ≥ 4.0 V, the driver IC remains active (t_{on}) until the next phase switching. During this period, output circuit is turned on.
- If the active drive time of each phase is assumed to 't_o', the following relation can be established:

$$t_o = t_{off} + t_{on}$$

↑ ↑
 Fixed Rotation speed
 constant proportional constant

$$t_{off} = 0.69 \cdot C2 \cdot R2 \dots\dots\dots \textcircled{1}$$

LB1860,1860M,1861,1861M

- From this relation, it can be observed that the 't_o' and 't_{on}' are in proportional relation with each other, and that the 't_{on}/t_o' equals the 'on' time duty. As a result, a certain rotation speed can be fixed despite the fact that rotation speed exclusively depends on each motor.
- At the start, the 't_{on}' value becomes longer while the 't_{off}' value remains unchanged. This means that the 't_{off}/t_o' duty becomes small enough compared to normal rotation mode. Therefore, the same start torque as that of the full speed rotation can be obtained because the 'on' operation time duty increases. This enables the motor to start at a very low speed.

(2) Supply voltage (V_{IN} pin)

- The LB1860 has the internal parallel regulator which supplies power to the Hall amplifier circuit and the control block. Therefore, the driver ICs are not affected by power source fluctuations and kickbacks from the motor. They maintain the stable operations even if noise signals such as surge are generated.
- Set the resistance R1 between V_{CC} and V_{IN} so that the I_{CC} current of 6 mA to 50 mA can flow onto the V_{IN} pin within the supply voltage range of a fan motor.
- V_{IN} is 6.7 V typ at I_{CC} = 7 mA.
- The current flowing into V_{IN} is calculated using the equation shown below.

$$I_{CC} = \frac{V_{CC} - V_{IN}}{R1} \dots\dots\dots ②$$

- Consideration given to surge voltage
- The maximum allowable current at V_{IN} pin is 200 mA. Therefore, the pin is designed to withstand abnormal positive voltage of:

$$V_{surge} = V_{IN} + R1 \times 200 \text{ mA} \dots\dots\dots ③$$

(3) Hall input pin voltage (Pins IN⁻, IN⁺)

- Set the voltage levels of the input pin for the Hall element output and the Hall element output voltage to within the range of 0 V to V_{IN} - 1.5 V.
- The gain between the hall input pin and the output pin is 100 dB or greater. The offset voltage of the hall input amp is ±7 mV, therefore, the hall element output must be set with the offset voltage (±7 mV) considered.

(4) Output transistor (Pins OUT1, OUT2)

- Output current I_O = 1.5 A max
- Output saturation voltage V_{O sat} = 1.15 V/1.0 A typ
- Output limiting voltage V_{OLM} = 57 V typ (LB1860, 1860M)
V_{OLM} = 32 V typ (LB1861,1861M)
- Since the LB1860 series have a protect zener diode between collector and base, the kickback voltage induced by the coil is cut at V_{OLM} = 57 V (32 V). When external capacitors are connected between OUT and GND, the capacitance should not exceed 10 μF.

(5) Output protection function (C pin)

- Capacitor pin used in forming an automatic return circuit.
- If rotation is stopped due to overload, the pin voltage level increases and then forces the output to become inactive. In this case, after proper load adjustment, the output returns to the 'drive' mode from the 'stop' mode automatically. By changing the capacitor value, the lock detect time period can be set.

For C marked with 1 μF

Lock detect time	Approximately 2 sec.
Lock protect time (output ON)	Approximately 1 sec.
(output OFF)	Approximately 6 sec.

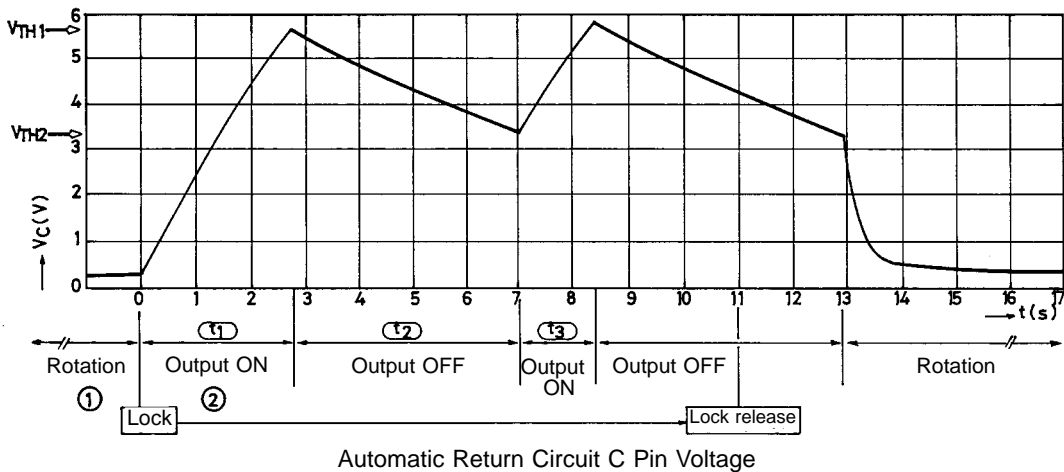

- ① When a fan is rotating, the capacitor is charged at 4 μA (typ) and discharged through the C with pulses according to the rotational speed.
 - ② When a fan is locked, no discharge occurs through the C and the C voltage rises, turning OFF the output at $0.8 \times V_{IN}$.
 - ③ When the output is turned OFF, discharge occurs through the C at 0.5 μA (typ). If the lock is not released when the C voltage drops to V_{TH2} , the capacitor is charged to V_{TH1} again. (At this moment, the output is turned ON.) These operations ② and ③ repeated at a cycle of approximately $t_{on} : t_{off} = 1:6$ protect a motor.
 - ④ If the lock is released when the C voltage drops to V_{TH2} , the output is turned ON, starting rotation.
- (6) Rotation detect signal (RD pin)
 - Open collector output (Drive mode: "L", Stop mode: "H")
 - (7) Radio noise reducing (Pins B1, B2)
 - Base pin of Darlington connection output transistor
 - If radio noises need to be processed properly, the following actions should be taken:
 - ① Connect a capacitor of 0.01 μ to 0.1 μF between B1 and B2.
 - ② Connect a capacitor of 0.001 μ to 0.01 μF between OUT and B.
 If output causes oscillation, add a resistor of 200 Ω to 1 kΩ in series with a capacitor.
 - (8) Thermal shutdown function
 - Shutdown the driver output in case of coil short-circuiting and abnormal IC heating.

Thermistor-controlled Application Circuit Example

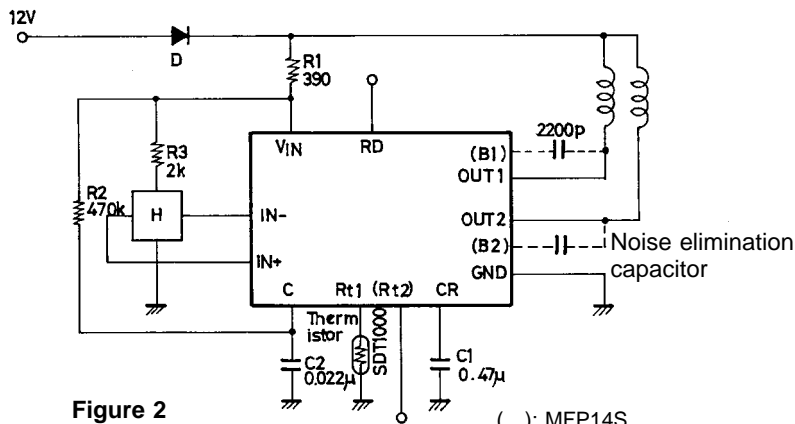

Figure 2

() : MFP14S

Unit (resistance: Ω, capacitance: F)

Use of a thermistor enables motor speed to be sensitive to the operating ambient temperature.

The R_t pin voltage at $T_a = 20\text{ }^\circ\text{C}$ has 1.42 ms of 't_{off}' as calculated in expression 4 with the application constant of Figure 2. However, the R_t pin voltage at $T_a = 40\text{ }^\circ\text{C}$ is reduced into less than the V_{ct} (= 1.3 V) level, which results in a 0 of 't_{off}'. This means the 100% duty.

$$t = -C2 \cdot R2 \cdot \ln \frac{(V_{IN} - V_{Rt})}{V_{IN} - V_{Ct}} \dots\dots\dots ④$$

Output Timing Chart

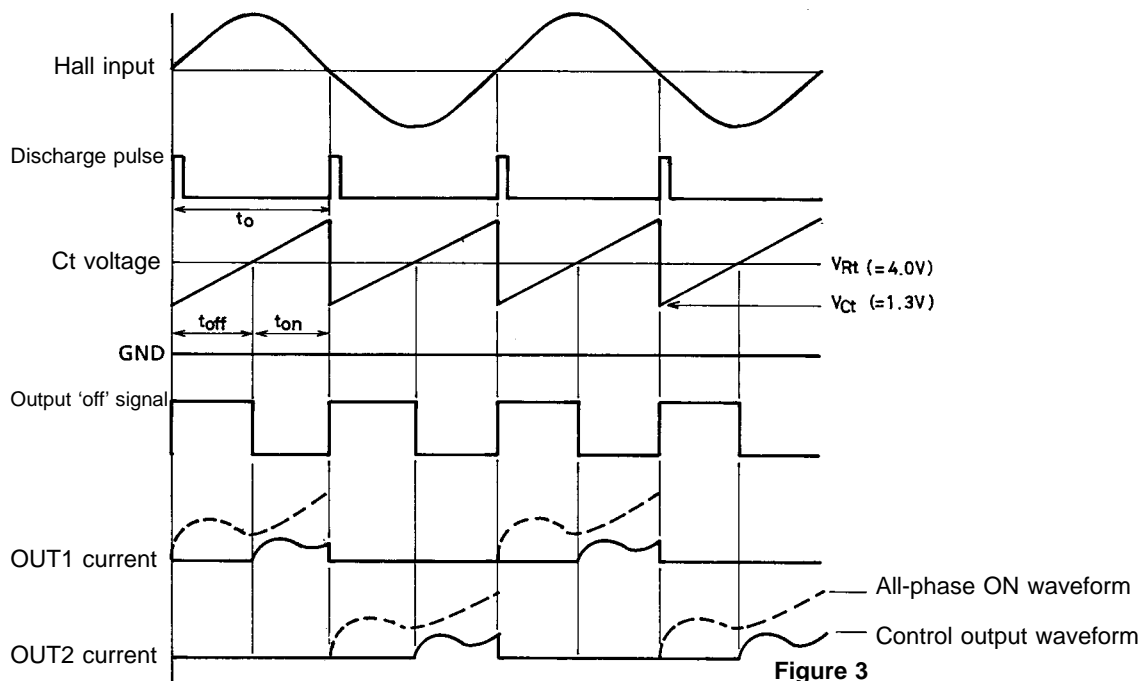
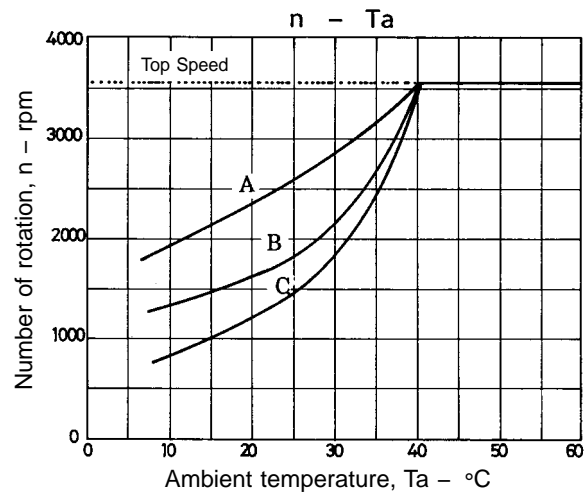

Figure 3



- No products described or contained herein are intended for use in surgical implants, life-support systems, aerospace equipment, nuclear power control systems, vehicles, disaster/crime-prevention equipment and the like, the failure of which may directly or indirectly cause injury, death or property loss.
- Anyone purchasing any products described or contained herein for an above-mentioned use shall:
 - ① Accept full responsibility and indemnify and defend SANYO ELECTRIC CO., LTD., its affiliates, subsidiaries and distributors and all their officers and employees, jointly and severally, against any and all claims and litigation and all damages, cost and expenses associated with such use:
 - ② Not impose any responsibility for any fault or negligence which may be cited in any such claim or litigation on SANYO ELECTRIC CO., LTD., its affiliates, subsidiaries and distributors or any of their officers and employees jointly or severally.
- Information (including circuit diagrams and circuit parameters) herein is for example only; it is not guaranteed for volume production. SANYO believes information herein is accurate and reliable, but no guarantees are made or implied regarding its use or any infringements of intellectual property rights or other rights of third parties.

This catalog provides information as of July, 1996. Specifications and information herein are subject to change without notice.