

阅读申明

- 1.本站收集的数据手册和产品资料都来自互联网，版权归原作者所有。如读者和版权方有任何异议请及时告之，我们将妥善解决。
- 2.本站提供的中文数据手册是英文数据手册的中文翻译，其目的是协助用户阅读，该译文无法自动跟随原稿更新，同时也可能存在翻译上的不当。建议读者以英文原稿为参考以便获得更精准的信息。
- 3.本站提供的产品资料，来自厂商的技术支持或者使用者的心得体会等，其内容可能存在描述上的差异，建议读者做出适当判断。
- 4.如需与我们联系，请发邮件到marketing@iczoom.com，主题请标有“数据手册”字样。

Read Statement

1. The datasheets and other product information on the site are all from network reference or other public materials, and the copyright belongs to the original author and original published source. If readers and copyright owners have any objections, please contact us and we will deal with it in a timely manner.
2. The Chinese datasheets provided on the website is a Chinese translation of the English datasheets. Its purpose is for reader's learning exchange only and do not involve commercial purposes. The translation cannot be automatically updated with the original manuscript, and there may also be improper translations. Readers are advised to use the English manuscript as a reference for more accurate information.
3. All product information provided on the website refer to solutions from manufacturers' technical support or users the contents may have differences in description, and readers are advised to take the original article as the standard.
4. If you have any questions, please contact us at marketing@iczoom.com and mark the subject with "Datasheets" .

Features

- Internal Frequency-to-voltage Converter
- Externally Controlled Integrated Amplifier
- Automatic Soft Start with Minimized “Dead Time”
- Voltage and Current Synchronization
- Retriggering
- Triggering Pulse Typically 155 mA
- Internal Supply-voltage Monitoring
- Temperature-compensated Reference Source
- Current Requirement ≤ 3 mA

Electrostatic sensitive device.
Observe precautions for handling.



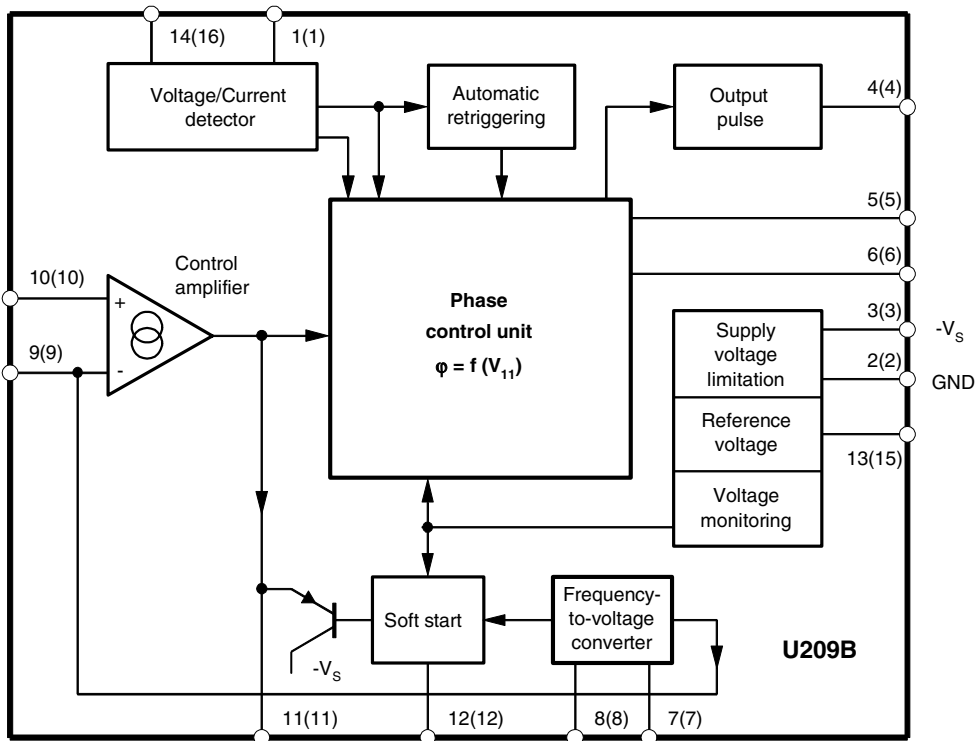
Phase Control IC for Tacho Applications

Description

The integrated circuit U209B is designed as a phase-control circuit in bipolar technology with an internal frequency-to-voltage converter. The device includes an internal open-loop amplifier, which means it can be used for motor speed control with tacho feedback.

The U209B is a 14-pin shrink version of the U211B with reduced features. Using the U209B, the designer is able to realize sophisticated as well as economic motor control systems.

Figure 1. Block Diagram



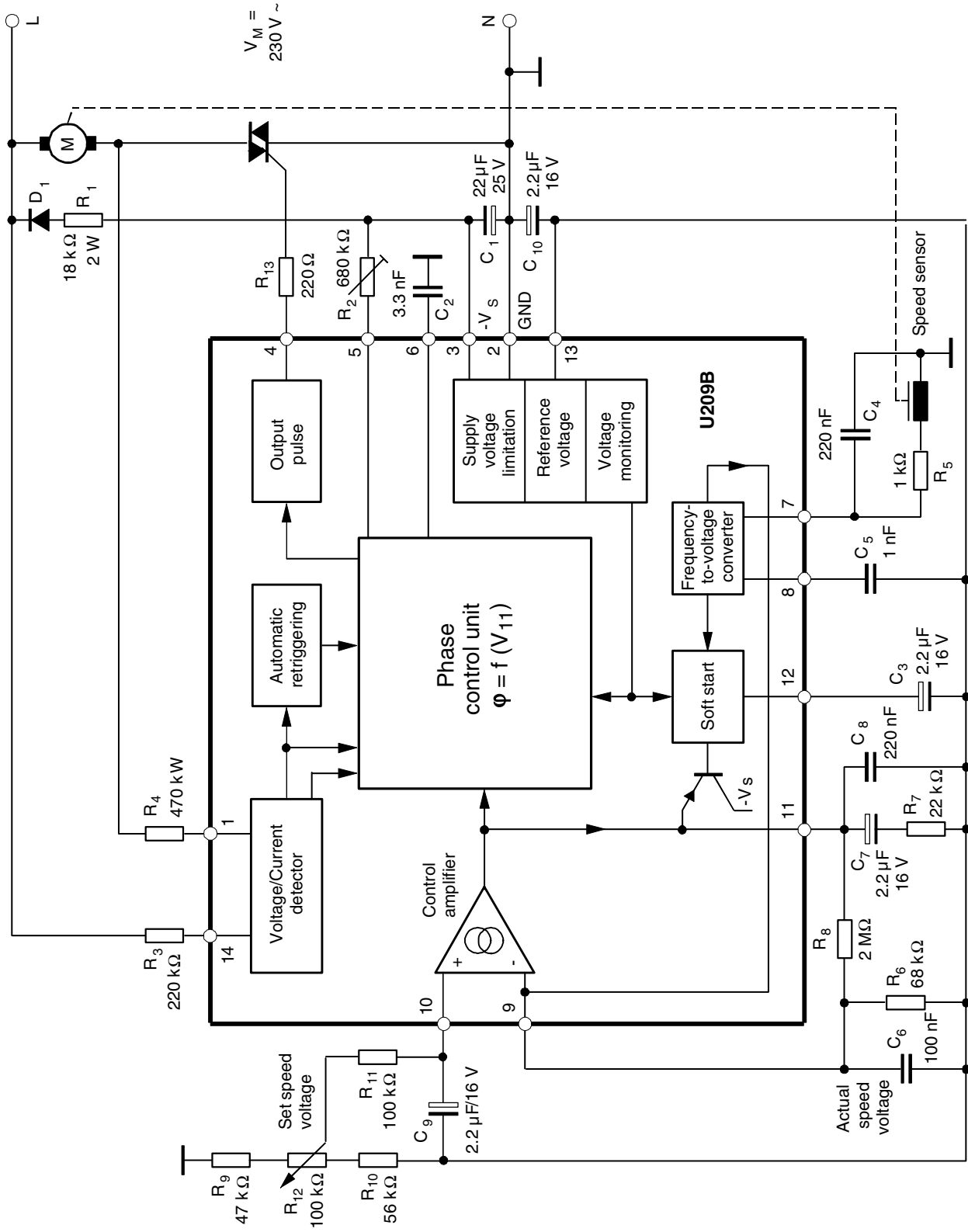
Pin numbers in brackets refer to SO16 Package

U209B

Rev. 4765A-INDCO-01/04

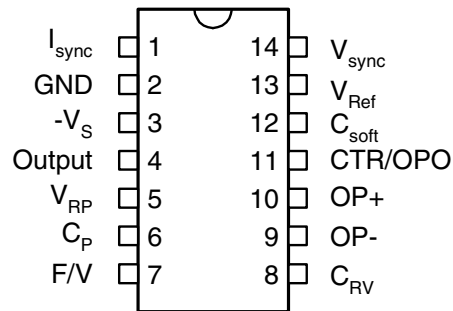


Figure 2. Block Diagram with Typical Circuitry for Speed Regulation



Pin Configuration

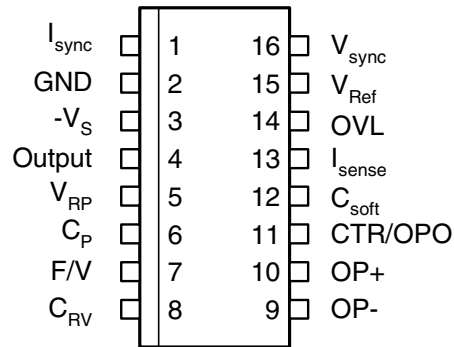
Figure 3. Pinning DIP14



Pin Description

Pin	Symbol	Function
1	I_{sync}	Current synchronization
2	GND	Ground
3	$-V_S$	Supply voltage
4	Output	Trigger pulse output
5	V_{RP}	Ramp current adjust
6	C_P	Ramp voltage
7	F/V	Frequency-to-voltage converter
8	C_{RV}	Charge pump
9	OP-	OP inverting input
10	OP+	OP non-inverting input
11	CTR/OPO	Control input/OP output
12	C_{soft}	Soft start
13	V_{Ref}	Reference voltage
14	V_{sync}	Voltage synchronization

Figure 4. Pinning SO16



Pin Description

Pin	Symbol	Function
1	I_{sync}	Current synchronization
2	GND	Ground
3	$-V_S$	Supply voltage
4	Output	Trigger pulse output
5	V_{RP}	Ramp current adjust
6	C_P	Ramp voltage
7	F/V	Frequency-to-voltage converter
8	C_{RV}	Charge pump
9	OP-	OP inverting input
10	OP+	OP non-inverting input
11	CTR/OPO	Control input/OP output
12	C_{soft}	Soft start
13	I_{sense}	Load-current sensing
14	OVL	Overload adjust
15	V_{Ref}	Reference voltage
16	V_{sync}	Voltage synchronization

Description

Mains Supply

The U209B is equipped with voltage limiting and can therefore be supplied directly from the mains. The supply voltage between pin 2 (+ pol/⊥) and pin 3 builds up across D_1 and R_1 , and is smoothed by C_1 . The value of the series resistance can be approximated using:

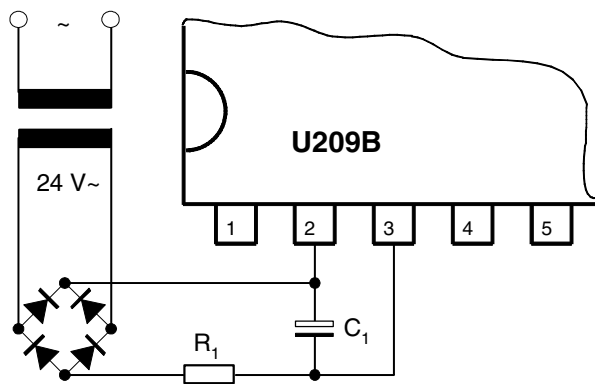
$$R_1 = \frac{V_M - V_S}{2 I_S}$$

Further information regarding the design of the mains supply can be found in the section “Design Calculations for Mains Supply” on page 9. The reference voltage source on pin 13 of typically -8.9 V is derived from the supply voltage and represents the reference level of the control unit.

Operation using an externally stabilized DC voltage is not recommended.

If the supply cannot be taken directly from the mains because the power dissipation in R_1 would be too large, the circuit as shown in Figure 5 should be used.

Figure 5. Supply Voltage for High Current Requirements



Phase Control

The function of the phase control is largely identical to that of the well known integrated circuit U2008B. The phase angle of the trigger pulse is derived by comparing the ramp voltage (which is mains synchronized by the voltage detector) with the set value on the control input pin 4. The slope of the ramp is determined by C_2 and its charging current. The charging current can be varied using R_2 on pin 5. The maximum phase angle α_{max} can also be adjusted by using R_2 .

When the potential on pin 6 reaches the nominal value predetermined at pin 11, a trigger pulse is generated whose width t_p is determined by the value of C_2 (the value of C_2 and hence the pulse width can be evaluated by assuming $8 \mu s/nF$).

The current sensor on pin 1 ensures that, for operation with inductive loads, no pulse is generated in a new half cycle as long as a current from the previous half cycle is still flowing in the opposite direction to the supply voltage at that instant. This makes sure that “gaps” in the load current are prevented.

The control signal on pin 11 can be in the range 0 V to -7 V (reference point pin 2).

If $V_{11} = -7 V$, the phase angle is at maximum = α_{max} , i.e., the current flow angle is at minimum. The minimum phase angle α_{min} is when $V_{11} = V_{pin 2}$.

Voltage Monitoring

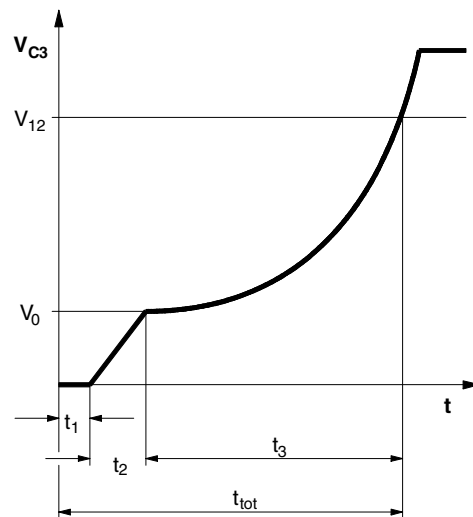
As the voltage is built up, uncontrolled output pulses are avoided by internal voltage surveillance. At the same time, all latches in the circuit (phase control, soft start) are reset and the soft-start capacitor is short-circuited. Used with a switching hysteresis of 300 mV, this system guarantees defined start-up behavior each time the supply voltage is switched on or after short interruptions of the mains supply.

Soft Start

As soon as the supply voltage builds up (t_1), the integrated soft start is initiated. Figure 6 shows the behavior of the voltage across the soft-start capacitor, which is identical with the voltage on the phase control input on pin 11. This behavior guarantees a gentle start-up for the motor and automatically ensures the optimum run-up time.

C_3 is first charged up to the starting voltage V_0 with typically 30 μA current (t_2). By reducing the charging current to approximately 4 μA , the slope of the charging function is also substantially reduced, so that the rotational speed of the motor only slowly increases. The charging current then increases as the voltage across C_3 increases giving a progressively rising charging function which accelerates the motor with increasing rotational speed. The charging function determines the acceleration up to the set-point. The charging current can have a maximum value of 50 mA.

Figure 6. Soft Start



- t_1 = build-up of supply voltage
- t_2 = charging of C_3 to starting voltage
- $t_1 + t_2$ = dead time
- t_3 = run-up time
- t_{tot} = total start-up time to required speed

Frequency-to-voltage Converter

The internal frequency-to-voltage converter (f/V converter) generates a DC signal on pin 9 which is proportional to the rotational speed, using an AC signal from a tachogenerator or a light beam whose frequency is in turn dependent on the rotational speed. The high impedance input with a switch-on threshold of typically -100 mV gives very reliable operation even when relatively simple tachogenerators are employed. The tachofrequency is given by:

$$f = \frac{n}{60} p(\text{Hz})$$

n = revolution per minute

p = number of pulses per revolution

The converter is based on the charge pumping principle. With each negative half wave of the input signal, a quantity of charge determined by C_5 is internally amplified and then integrated by C_6 at the converter output on pin 9. The conversion constant is determined by C_5 , its charging voltage of V_{ch} , R_6 (pin 9) and the internally adjusted charge amplification G_i .

$$k = G_i \times C_5 \times R_6 \times V_{ch}$$

The analog output voltage is given by

$$\begin{aligned} V_o &= k \times f \\ \text{where: } V_{ch} &= 6.7 \text{ V} \\ G_i &= 8.3 \end{aligned}$$

The values of C_5 and C_6 must be such that for the highest possible input frequency, the maximum output voltage V_o does not exceed 6 V. The R_i on pin 8 is approximately 6 k Ω while C_5 is charging up. To obtain good linearity of the f/V converter the time constant resulting from R_i and C_5 should be considerably less (1/5) than the time span of the negative half cycle for the highest possible input frequency. The amount of remaining ripple on the output voltage on pin 9 is dependent on C_5 , C_6 and the internal charge amplification.

$$\Delta V_o = \frac{G_i \times V_{ch} \times C_5}{C_6}$$

The ripple ΔV_o can be reduced by using larger values of C_6 , however, the maximum conversion speed will then also be reduced.

The value of this capacitor should be chosen to fit the particular control loop where it is going to be used.

Control Amplifier

The integrated control amplifier with differential input compares the set value (pin 10) with the instantaneous value on pin 9, and generates a regulating voltage on the output pin 11 (together with external circuitry on pin 12). This pin always tries to keep the real voltage at the value of the set voltages. The amplifier has a transmittance of typically 110 $\mu\text{A/V}$ and a bipolar current source output on pin 11 which operates with typically $\pm 100 \mu\text{A}$. The amplification and frequency response are determined by R_7 , C_7 , C_8 and R_8 (can be left out). For operation as a power divider, C_4 , C_5 , R_6 , C_6 , R_7 , C_7 , C_8 and R_8 can be left out. Pin 9 should be connected with pin 11 and pin 7 with pin 2. The phase angle of the triggering pulse can be adjusted using the voltage on pin 10. An internal limiting circuit prevents the voltage on pin 11 from becoming more negative than $V_{13} + 1 \text{ V}$.

Pulse-output Stage

The pulse-output stage is short-circuit protected and can typically deliver currents of 125 mA. For the design of smaller triggering currents, the function $I_{GT} = f(R_{GT})$ can be taken from Figure 15 on page 15.

Automatic Retriggering

The automatic retriggering prevents half cycles without current flow, even if the triacs have been turned off earlier, e.g., due to not exactly centered collector (brush lifter) or in the event of unsuccessful triggering. If necessary, another triggering pulse is generated after a time lapse of $t_{pp} = 4.5 t_p$ and this is repeated until either the triac fires or the half cycle finishes.

General Hints and Explanation of Terms

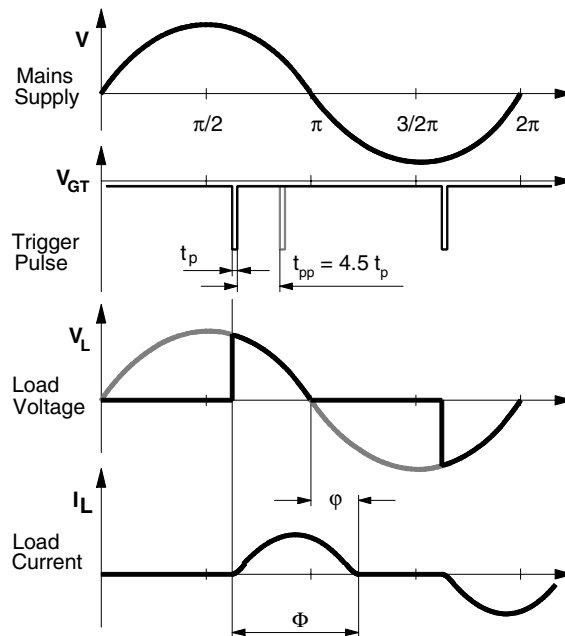
To ensure safe and trouble-free operation, the following points should be taken into consideration when circuits are being constructed or in the design of printed circuit boards.

The connecting lines from C_2 to pin 6 and pin 2 should be as short as possible, and the connection to pin 2 should not carry any additional high current such as the load current. When selecting C_2 , a low temperature coefficient is desirable.

The common (earth) connections of the set-point generator, the tachometer generator and the final interference suppression capacitor C_4 of the f/V converter should not carry load current.

The tachometer generator should be mounted without influence by strong stray fields from the motor.

Figure 7. Explanation of Terms in Phase Relationship



Design Calculations for Mains Supply

The following equations can be used for the evaluation of the series resistor R₁ for worst case conditions:

$$R_{1\max} = 0.85 \frac{V_{M\min} - V_{S\max}}{2 I_{\text{tot}}}$$

$$R_{1\min} = \frac{V_M - V_{S\min}}{2 I_{S\max}}$$

$$P_{(R1\max)} = \frac{(V_{M\max} - V_{S\min})^2}{2 R_1}$$

where:

V_M = Mains voltage 230 V

V_S = Supply voltage on pin 3

I_{tot} = Total DC current requirement of the circuit

= I_S + I_p + I_x

I_{Smax} = Current requirement of the IC in mA

I_p = Average current requirement of the triggering pulse

I_x = Current requirement of other peripheral components

R₁ can be easily evaluated from Figure 17 on page 16 to Figure 19 on page 16.

Absolute Maximum Ratings

Stresses beyond those listed under “Absolute Maximum Ratings” may cause permanent damage to the device. This is a stress rating only and functional operation of the device at these or any other conditions beyond those indicated in the operational sections of this specification is not implied. Exposure to absolute maximum rating conditions for extended periods may affect device reliability.

Reference point pin 2, unless otherwise specified

Parameters	Pins	Symbol	Value	Unit
Current requirement	3	$-I_S$	30	mA
$t \leq 10 \mu s$	3	$-i_s$	100	mA
Synchronization current	1	I_{syncI}	5	mA
	14	I_{syncV}	5	mA
$t < 10 \mu s$	1	$\pm i_I$	35	mA
$t < 10 \mu s$	14	$\pm i_V$	35	mA
f/V Converter				
Input current	7	I_{eff}	3	mA
$t < 10 \mu s$	7	$\pm i_i$	13	mA
Phase Control				
Input voltage	11	$-V_I$	0 to 7	V
Input current	11	$\pm i_I$	500	μA
Soft Start				
Input voltage	12	$-V_I$	$ V_{13} $ to 0	V
Pulse Output				
Reverse voltage	4	V_R	V_S to 5	V
Amplifier				
Input voltage	10	$-V_I$	$ V_S $	
Pin 8 open	9	$-V_I$	$ V_{13} $ to 0	V
Reference Voltage Source				
Output current	13	I_o	7.5	mA
Power dissipation		P_{tot}	570	mW
$T_{amb} = 45^\circ C$		P_{tot}	320	mW
$T_{amb} = 80^\circ C$				
Storage temperature range		T_{stg}	-40 to +125	$^\circ C$
Junction temperature		T_j	125	$^\circ C$
Ambient temperature range		T_{amb}	-10 to +100	$^\circ C$

Thermal Resistance

Parameters	Symbol	Value	Unit
Junction ambient	R_{thJA}	140	K/W
DIP14	R_{thJA}	180	K/W
SO16 on p.c. board	R_{thJA}	100	K/W
SO16 on ceramic substrate	R_{thJA}		

Electrical Characteristics

$-V_S = 13.0\text{ V}$, $T_{\text{amb}} = 25^\circ\text{C}$, reference point pin 2, unless otherwise specified

Parameters	Test Conditions	Pins	Symbol	Min.	Typ.	Max.	Unit
Supply voltage for mains operation		3	$-V_S$	13.0		V_{Limit}	V
Supply voltage limitation	$-I_S = 3\text{ mA}$	3	$-V_S$	14.6		16.6	V
	$-I_S = 30\text{ mA}$			14.7		16.8	V
DC supply current	$-V_S = 13.0\text{ V}$	3	$-I_S$	1.1	2.5	3.0	mA
Reference voltage source	$-I_L = 10\text{ }\mu\text{A}$ $-I_L = 5\text{ mA}$	13	V_{Ref}	8.6	8.9	9.2	V
				8.3		9.1	V
Temperature coefficient		13	$TC_{V_{\text{Ref}}}$			0.5	mV/K
Voltage Monitoring							
Turn-on threshold		3	$-V_{\text{TON}}$		11.2	13	V
Turn-off threshold		3	$-V_{\text{TOFF}}$	9.9	10.9		V
Phase-control Currents							
Current synchronization		1	$\pm I_{\text{syncI}}$	0.35		2.0	mA
Voltage synchronization		14	$\pm I_{\text{syncV}}$	0.35		2.0	mA
Voltage limitation	$\pm I_L = 5\text{ mA}$	1, 14	$\pm V_I$	1.4	1.6	1.8	V
Reference Ramp (see Figure 8 on page 13)							
Charge current	$I_6 = f(R_5)$ $R_5 = 1\text{ k}\Omega$ to $820\text{ k}\Omega$	6	I_6	1		20	μA
R ϕ -reference voltage	$\alpha \geq 180^\circ$	5, 3	$V_{\phi\text{Ref}}$	1.06	1.13	1.18	V
Temperature coefficient		5	$TC_{V_{\phi\text{Ref}}}$		0.5		mV/K
Output Pulse							
Output pulse current	$R_V = 0$, $V_{\text{GT}} = 1.2\text{ V}$	4	I_O	100	155	190	mA
Reverse current		4	I_{OR}		0.01	3.0	μA
Output pulse width		5, 2	t_p		8		$\mu\text{s/nF}$
Automatic Retriggering							
Repetition rate		4	t_{pp}	3	4.5	6	t_p
Amplifier							
Common-mode signal range		9, 10	V_{ICR}	$(V_{13} - 1\text{ V})$		$(V_2 - 1\text{ V})$	V
Input bias current		10	I_{IB}		0.01	1	mA
Input offset voltage		9, 10	V_{IO}		10		mV
Output current		11	$-I_O$ $+I_O$	75	110	145	μA
				88	120	165	μA
Short circuit forward, transmittance	$I_{11} = f(V_{9/10})$	11	Y_f		1000		$\mu\text{A/V}$

Electrical Characteristics (Continued)

$-V_S = 13.0\text{ V}$, $T_{\text{amb}} = 25^\circ\text{C}$, reference point pin 2, unless otherwise specified

Parameters	Test Conditions	Pins	Symbol	Min.	Typ.	Max.	Unit
Frequency-to-voltage Converter							
Input bias current		7	I_{IB}		0.6	2	μA
Input voltage limitation	$\pm I_{\text{I}} = -1\text{ mA}$	7	$-V_{\text{I}}$ $+V_{\text{I}}$	660 7.25		750 8.05	mV V
Turn-on threshold		7	$-V_{\text{TON}}$		100	150	mV
Turn-off threshold		7	$-V_{\text{TOFF}}$	20	50		mV
Discharge current	(see Figure 2 on page 2)	8	I_{dis}		0.5		mA
Charge transfer voltage		8	V_{ch}	6.50	6.70	6.90	V
Charge transfer gain	$I_{\text{g}}/I_{\text{g}}$	8, 9	G_{i}	7.5	8.3	9.0	
Conversion factor	$C_{\text{g}} = 1\text{ nF}$, $R_{\text{g}} = 100\text{ k}\Omega$		k		5.5		mV/Hz
Output operating range	f/V output, reference point pin 13	9	V_{O}		0-6		V
Linearity					± 1		%
Soft Start, f/V Converter Non-active (see Figure 10 on page 13 and Figure 11 on page 14)							
Starting current	$V_{12} = V_{13}$, $V_7 = V_2$	12	I_{O}	20	30	50	μA
Final current	$V_{12} = -0.5\text{ V}$	12	I_{O}	50	85	130	μA
Soft Start, f/V Converter Active (see Figure 9 on page 13, Figure 12 on page 14)							
Starting current	$V_{12} = V_{13}$	12	I_{O}	2	4	6	μA
Final current	$V_{12} = -0.5\text{ V}$	12	I_{O}	30	55	80	μA
Discharge current	Restart pulse	12	$-I_{\text{O}}$	0.5	3	10	mA

Figure 8. Ramp Control

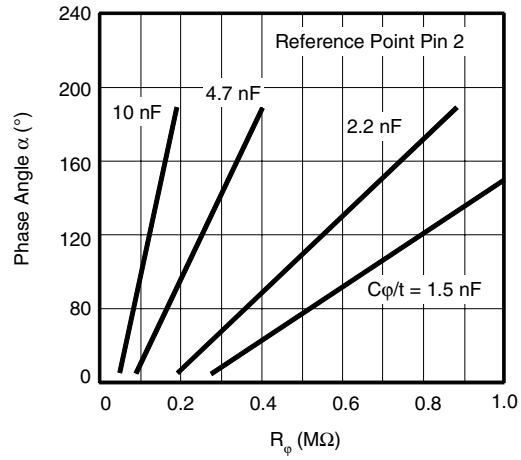


Figure 9. Soft-start Charge Current (f/V Converter Active)

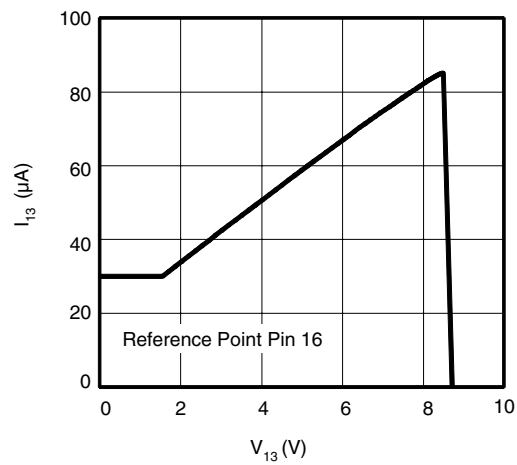


Figure 10. Soft-start Charge Current (f/V Converter Non-active)

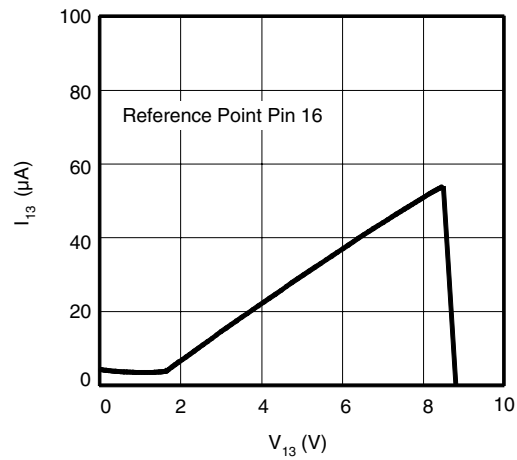


Figure 11. Soft-start Voltage (f/V Converter Non-active)

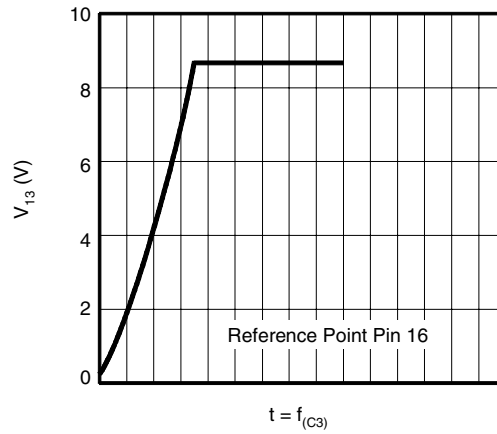


Figure 12. Soft-start Voltage (f/V Converter Active)

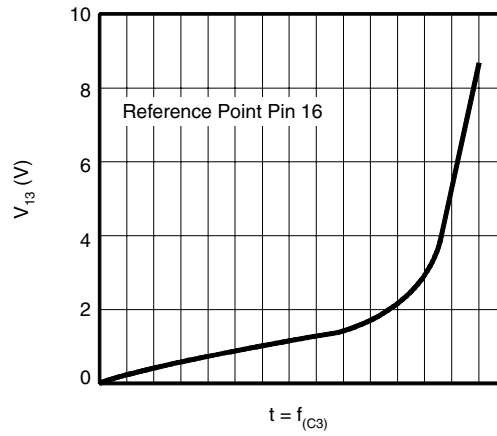


Figure 13. f/V Converter Voltage Limitation

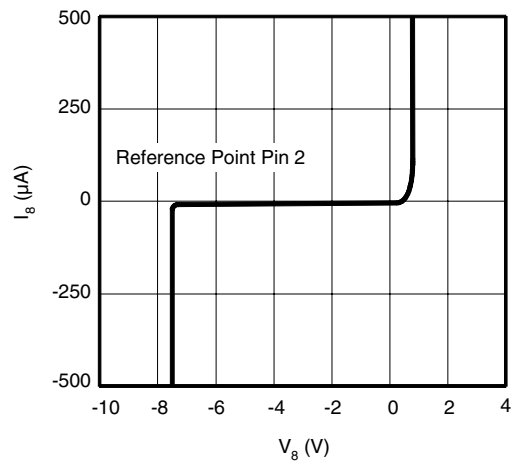


Figure 14. Soft-start Function

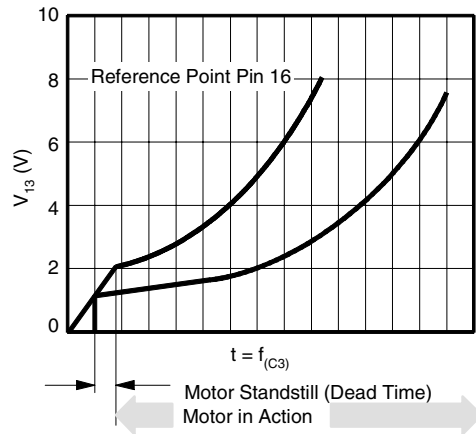


Figure 15. Amplifier Output Characteristics

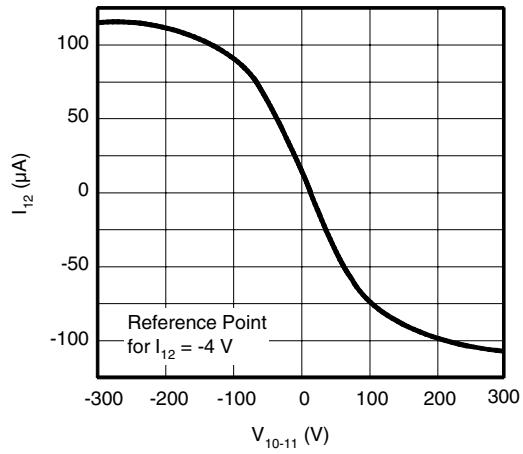


Figure 16. Pulse Output

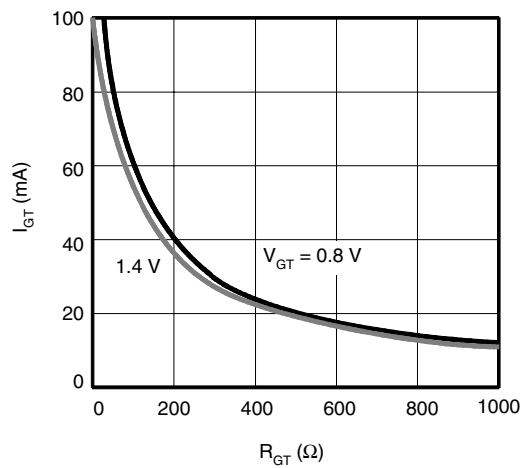


Figure 17. Determination of R_1

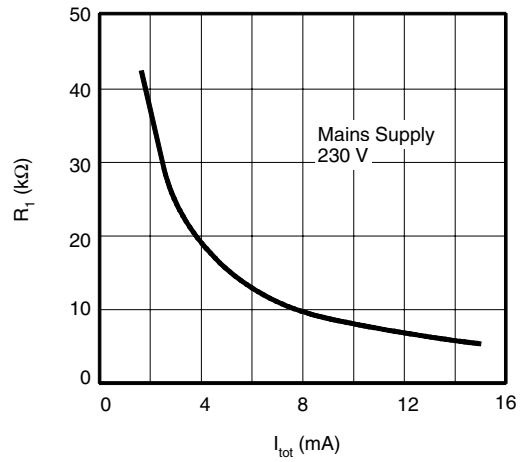


Figure 18. Power Dissipation of R_1 According to Current Consumption

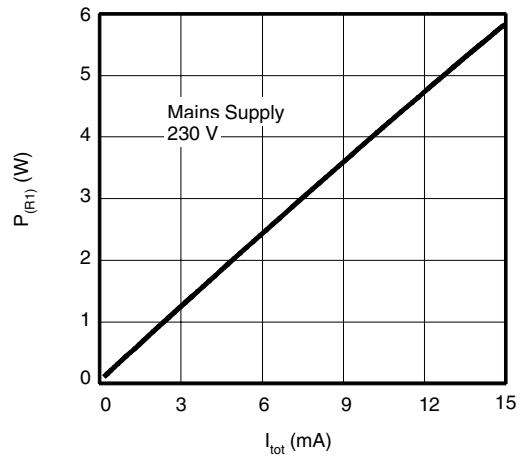
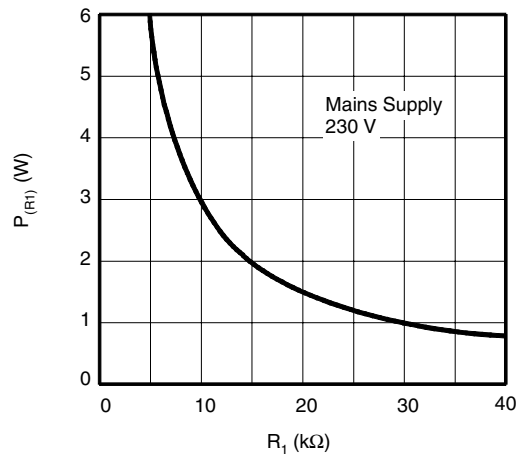


Figure 19. Power Dissipation of R_1



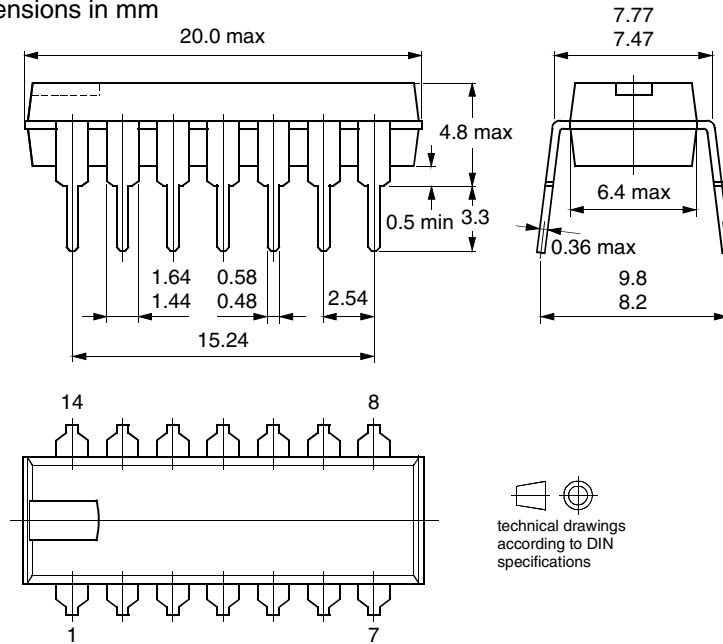
Ordering Information

Extended Type Number	Package	Remarks
U209B-x	DIP14	Tube
U209B-xFP	SO16	Tube
U209B-xFPG3	SO16	Taped and reeled

Package Information

Package DIP14

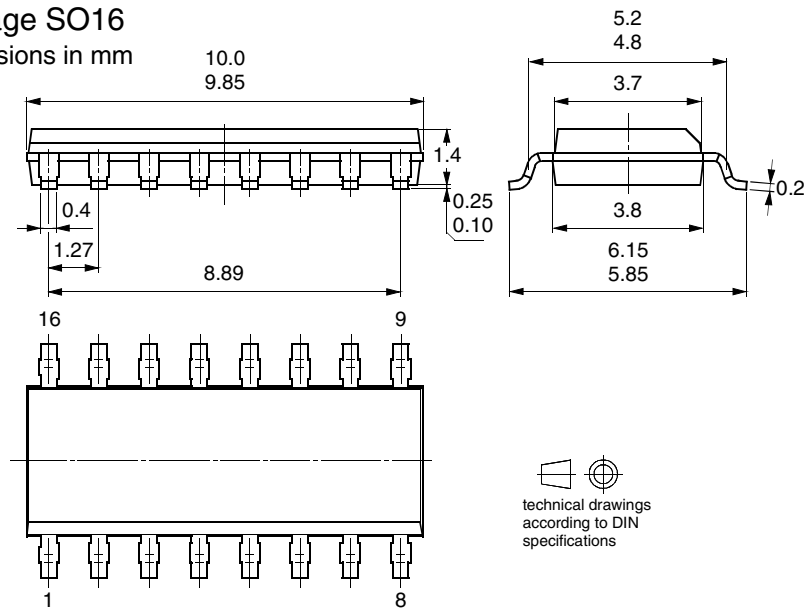
Dimensions in mm



technical drawings according to DIN specifications

Package SO16

Dimensions in mm



technical drawings according to DIN specifications



Atmel Corporation

2325 Orchard Parkway
San Jose, CA 95131, USA
Tel: 1(408) 441-0311
Fax: 1(408) 487-2600

Regional Headquarters

Europe

Atmel Sarl
Route des Arsenalux 41
Case Postale 80
CH-1705 Fribourg
Switzerland
Tel: (41) 26-426-5555
Fax: (41) 26-426-5500

Asia

Room 1219
Chinachem Golden Plaza
77 Mody Road Tsimshatsui
East Kowloon
Hong Kong
Tel: (852) 2721-9778
Fax: (852) 2722-1369

Japan

9F, Tonetsu Shinkawa Bldg.
1-24-8 Shinkawa
Chuo-ku, Tokyo 104-0033
Japan
Tel: (81) 3-3523-3551
Fax: (81) 3-3523-7581

Atmel Operations

Memory

2325 Orchard Parkway
San Jose, CA 95131, USA
Tel: 1(408) 441-0311
Fax: 1(408) 436-4314

Microcontrollers

2325 Orchard Parkway
San Jose, CA 95131, USA
Tel: 1(408) 441-0311
Fax: 1(408) 436-4314

La Chantrerie
BP 70602
44306 Nantes Cedex 3, France
Tel: (33) 2-40-18-18-18
Fax: (33) 2-40-18-19-60

ASIC/ASSP/Smart Cards

Zone Industrielle
13106 Rousset Cedex, France
Tel: (33) 4-42-53-60-00
Fax: (33) 4-42-53-60-01

1150 East Cheyenne Mtn. Blvd.
Colorado Springs, CO 80906, USA
Tel: 1(719) 576-3300
Fax: 1(719) 540-1759

Scottish Enterprise Technology Park
Maxwell Building
East Kilbride G75 0QR, Scotland
Tel: (44) 1355-803-000
Fax: (44) 1355-242-743

RF/Automotive

Theresienstrasse 2
Postfach 3535
74025 Heilbronn, Germany
Tel: (49) 71-31-67-0
Fax: (49) 71-31-67-2340

1150 East Cheyenne Mtn. Blvd.
Colorado Springs, CO 80906, USA
Tel: 1(719) 576-3300
Fax: 1(719) 540-1759

Biometrics/Imaging/Hi-Rel MPU/ High Speed Converters/RF Datacom

Avenue de Rochepleine
BP 123
38521 Saint-Egreve Cedex, France
Tel: (33) 4-76-58-30-00
Fax: (33) 4-76-58-34-80

Literature Requests

www.atmel.com/literature

Disclaimer: Atmel Corporation makes no warranty for the use of its products, other than those expressly contained in the Company's standard warranty which is detailed in Atmel's Terms and Conditions located on the Company's web site. The Company assumes no responsibility for any errors which may appear in this document, reserves the right to change devices or specifications detailed herein at any time without notice, and does not make any commitment to update the information contained herein. No licenses to patents or other intellectual property of Atmel are granted by the Company in connection with the sale of Atmel products, expressly or by implication. Atmel's products are not authorized for use as critical components in life support devices or systems.

© Atmel Corporation 2004. All rights reserved.

Atmel® and combinations thereof are the registered trademarks of Atmel Corporation or its subsidiaries.

Other terms and product names may be the trademarks of others.



Printed on recycled paper.

4765A-INDCO-01/04