

## 阅读申明

- 1.本站收集的数据手册和产品资料都来自互联网，版权归原作者所有。如读者和版权方有任何异议请及时告之，我们将妥善解决。
- 2.本站提供的中文数据手册是英文数据手册的中文翻译，其目的是协助用户阅读，该译文无法自动跟随原稿更新，同时也可能存在翻译上的不当。建议读者以英文原稿为参考以便获得更精准的信息。
- 3.本站提供的产品资料，来自厂商的技术支持或者使用者的心得体会等，其内容可能存在描述上的差异，建议读者做出适当判断。
- 4.如需与我们联系，请发邮件到marketing@iczoom.com，主题请标有“数据手册”字样。

## Read Statement

1. The datasheets and other product information on the site are all from network reference or other public materials, and the copyright belongs to the original author and original published source. If readers and copyright owners have any objections, please contact us and we will deal with it in a timely manner.
2. The Chinese datasheets provided on the website is a Chinese translation of the English datasheets. Its purpose is for reader's learning exchange only and do not involve commercial purposes. The translation cannot be automatically updated with the original manuscript, and there may also be improper translations. Readers are advised to use the English manuscript as a reference for more accurate information.
3. All product information provided on the website refer to solutions from manufacturers' technical support or users the contents may have differences in description, and readers are advised to take the original article as the standard.
4. If you have any questions, please contact us at marketing@iczoom.com and mark the subject with "Datasheets" .

## HIGH SIDE SMART POWER SOLID STATE RELAY

TYPE	V <sub>DSS</sub>	R <sub>DS(on)</sub>	I <sub>n</sub> (*)	V <sub>CC</sub>
VN06SP	60 V	0.18 Ω	1.9 A	26 V

- MAXIMUM CONTINUOUS OUTPUT CURRENT (#):9 A @ T<sub>c</sub>=85°C
- 5 V LOGIC LEVEL COMPATIBLE INPUT
- THERMAL SHUT-DOWN
- UNDER VOLTAGE PROTECTION
- OPEN DRAIN DIAGNOSTIC OUTPUT
- INDUCTIVE LOAD FAST DEMAGNETIZATION
- VERY LOW STAND-BY POWER DISSIPATION

### DESCRIPTION

The VN06SP is a monolithic device made using STMicroelectronics VIPower Technology, intended for driving resistive or inductive loads with one side grounded.

Built-in thermal shut-down protects the chip from over temperature and short circuit.

The open drain diagnostic output indicates: open load in off state, and in on state, output shorted to

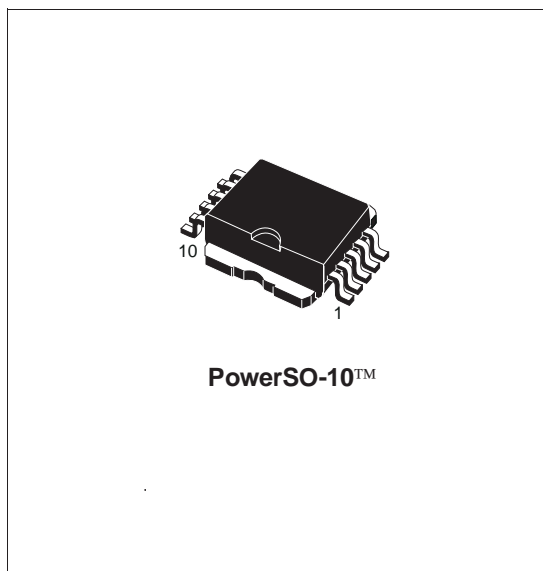

V<sub>CC</sub> and overtemperature. Fast demagnetization of inductive loads is achieved by negative (-18V) load voltage at turn-off.

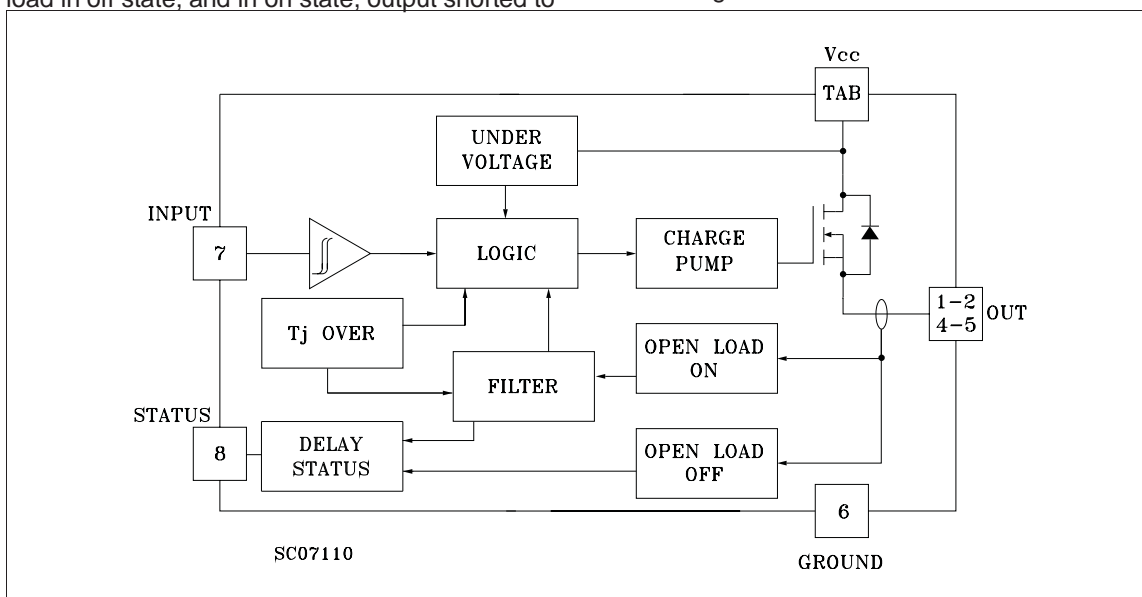

(\*) I<sub>n</sub> = Nominal current according to ISO definition for high side automotive switch (see note 1)

(#) The maximum continuous output current is the current at T<sub>c</sub> = 85 °C for a battery voltage of 13V which does not activate self protection.

**ABSOLUTE MAXIMUM RATING**

Symbol	Parameter	Value	Unit
$V_{(BR)DSS}$	Drain-Source Breakdown Voltage	60	V
$I_{OUT}$	Output Current (cont.) at $T_c = 85\text{ }^\circ\text{C}$	9	A
$I_R$	Reverse Output Current at $T_c = 85\text{ }^\circ\text{C}$	-9	A
$I_{IN}$	Input Current	$\pm 10$	mA
$-V_{CC}$	Reverse Supply Voltage	-4	V
$I_{STAT}$	Status Current	$\pm 10$	mA
$V_{ESD}$	Electrostatic Discharge (1.5 k $\Omega$ , 100 pF)	2000	V
$P_{tot}$	Power Dissipation at $T_c = 85\text{ }^\circ\text{C}$	27	W
$T_j$	Junction Operating Temperature	-40 to 150	$^\circ\text{C}$
$T_{stg}$	Storage Temperature	-55 to 150	$^\circ\text{C}$

**CONNECTION DIAGRAMS**

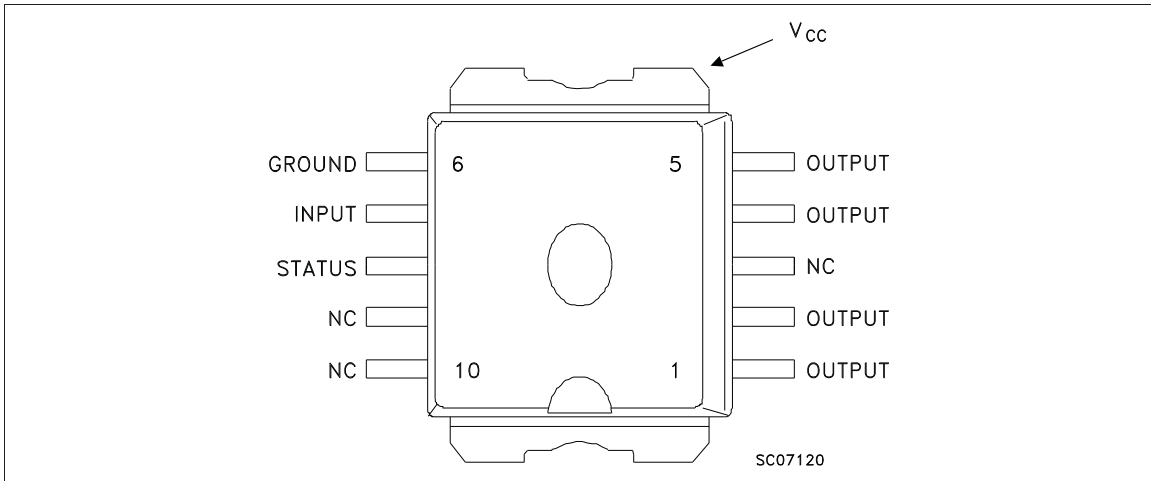

**CURRENT AND VOLTAGE CONVENTIONS**

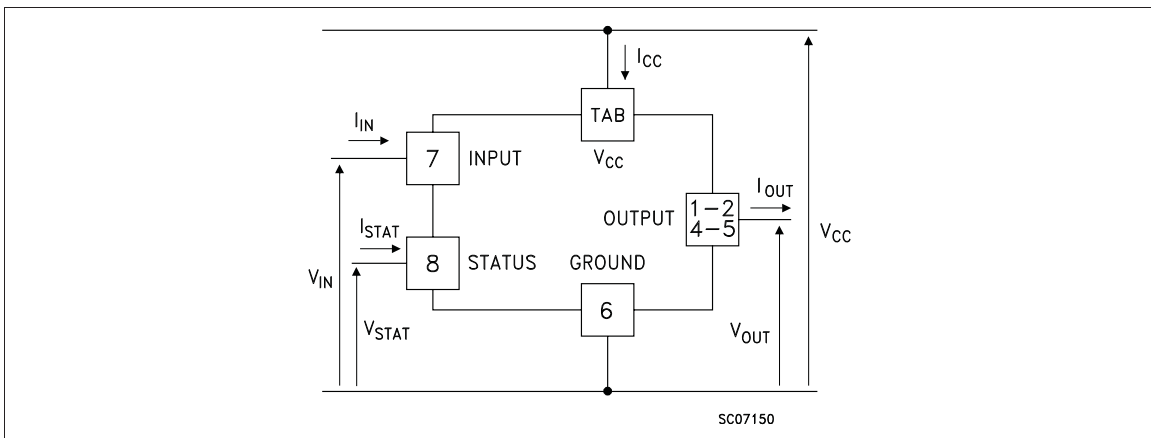

## THERMAL DATA

$R_{thj-case}$	Thermal Resistance Junction-case	Max	2.4	$^{\circ}C/W$
$R_{thj-amb}$	Thermal Resistance Junction-ambient	Max	50	$^{\circ}C/W$

When mounted using minimum recommended pad size on FR-4 board

ELECTRICAL CHARACTERISTICS ( $V_{CC} = 13 V$ ;  $-40 \leq T_j \leq 125 ^{\circ}C$  unless otherwise specified)

## POWER

Symbol	Parameter	Test Conditions	Min.	Typ.	Max.	Unit
$V_{CC}$	Supply Voltage		5.5	13	26	V
$I_n(^*)$	Nominal Current	$T_c = 85 ^{\circ}C$ $V_{DS(on)} \leq 0.5$ (note 1)	1.9			A
$R_{on}$	On State Resistance	$I_{OUT} = 1.9 A$ $I_{OUT} = 1.9 A$ $T_j = 25 ^{\circ}C$			0.36 0.18	$\Omega$ $\Omega$
$I_s$	Supply Current	Off State $T_j \geq 25 ^{\circ}C$ On State			50 15	$\mu A$ mA
$V_{DS(MAX)}$	Maximum Voltage Drop	$I_{OUT} = 8.5 A$ $T_c = 85 ^{\circ}C$			2.75	V

## SWITCHING

Symbol	Parameter	Test Conditions	Min.	Typ.	Max.	Unit
$t_{d(on)}(^{\wedge})$	Turn-on Delay Time Of Output Current	$I_{OUT} = 1.9 A$ Resistive Load Input Rise Time $< 0.1 \mu s$		20		$\mu s$
$t_r(^{\wedge})$	Rise Time Of Output Current	$I_{OUT} = 1.9 A$ Resistive Load Input Rise Time $< 0.1 \mu s$		20		$\mu s$
$t_{d(off)}(^{\wedge})$	Turn-off Delay Time Of Output Current	$I_{OUT} = 1.9 A$ Resistive Load Input Rise Time $< 0.1 \mu s$		25		$\mu s$
$t_f(^{\wedge})$	Fall Time Of Output Current	$I_{OUT} = 1.9 A$ Resistive Load Input Rise Time $< 0.1 \mu s$		6		$\mu s$
$(di/dt)_{on}$	Turn-on Current Slope	$I_{OUT} = 1.9 A$ $I_{OUT} = I_{OV}$		0.08	0.5 1	$A/\mu s$ $A/\mu s$
$(di/dt)_{off}$	Turn-off Current Slope	$I_{OUT} = 1.9 A$ $I_{OUT} = I_{OV}$		0.2	3 3	$A/\mu s$ $A/\mu s$
$V_{demag}$	Inductive Load Clamp Voltage	$I_{OUT} = 1.9 A$ $L = 1 mH$	-24	-18	-14	V

## LOGIC INPUT

Symbol	Parameter	Test Conditions	Min.	Typ.	Max.	Unit
$V_{IL}$	Input Low Level Voltage				0.8	V
$V_{IH}$	Input High Level Voltage		2		(•)	V
$V_{I(hyst.)}$	Input Hysteresis Voltage			0.5		V
$I_{IN}$	Input Current	$V_{IN} = 5 V$ $V_{IN} = 2 V$ $V_{IN} = 0.8 V$	25	250	500 250	$\mu A$ $\mu A$ $\mu A$
$V_{ICL}$	Input Clamp Voltage	$I_{IN} = 10 mA$ $I_{IN} = -10 mA$	5.5	6 -0.7	-0.3	V V

**ELECTRICAL CHARACTERISTICS** (continued)  
**PROTECTION AND DIAGNOSTICS**

Symbol	Parameter	Test Conditions	Min.	Typ.	Max.	Unit
V <sub>STAT</sub>	Status Voltage Output Low	I <sub>STAT</sub> = 1.6 mA			0.4	V
V <sub>USD</sub>	Under Voltage Shut Down			5		V
V <sub>SCL</sub>	Status Clamp Voltage	I <sub>STAT</sub> = 10 mA I <sub>STAT</sub> = -10 mA		6 -0.7		V V
I <sub>OV</sub>	Over Current	R <sub>LOAD</sub> < 10 mΩ -40 T <sub>c</sub> 125 °C			60	A
I <sub>AV</sub>	Average Current in Short Circuit	R <sub>LOAD</sub> < 10 mΩ T <sub>c</sub> = 85 °C		1.4		A
I <sub>OL</sub>	Open Load Current Level		5	80	180	mA
T <sub>TSD</sub>	Thermal Shut-down Temperature		140			°C
T <sub>R</sub>	Reset Temperature		125			°C
V <sub>OL</sub>	Open Load Voltage Level	Off-State (note 2)	2.5	3.75	5	V
t <sub>1(on)</sub>	Open Load Filtering Time	(note 3)	1	5	10	ms
t <sub>1(off)</sub>	Open Load Filtering Time	(note 3)	1	5	10	ms
t <sub>2(off)</sub>	Open Load Filtering Time	(note 3)	1	5	10	ms
t <sub>povl</sub>	Status Delay	(note 3)		5	10	μs
t <sub>poi</sub>	Status Delay	(note 3)	50	700		μs

(^) See Switching Time Waveforms

() The V<sub>IH</sub> is internally clamped at 6V about. It is possible to connect this pin to an higher voltage via an external resistor calculated to not exceed 10 mA at the input pin.

note 1: The Nominal Current is the current at T<sub>c</sub> = 85 °C for battery voltage of 13V which produces a voltage drop of 0.5 V

note 2: I<sub>OL(off)</sub> = (V<sub>CC</sub> - V<sub>OL</sub>)/R<sub>OL</sub> (see figure)

note 3: t<sub>1(on)</sub>: minimum open load duration which activates the status output

t<sub>1(off)</sub>: minimum load recovery time which desactivates the status output

t<sub>2(off)</sub>: minimum on time after thermal shut down which desactivates status output

t<sub>povl</sub> t<sub>poi</sub>: ISO definition (see figure).

Note 2 Relevant Figure

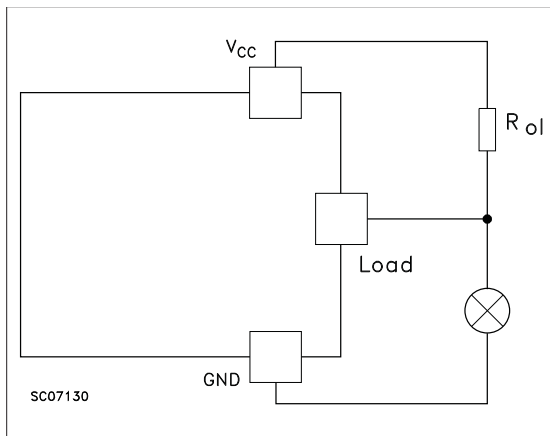

Note 3 Relevant Figure

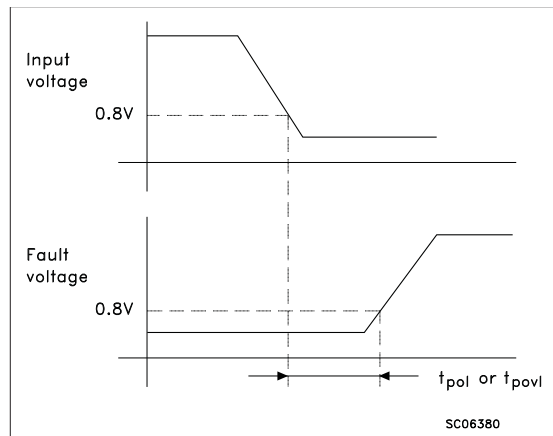

## Switching Time Waveforms

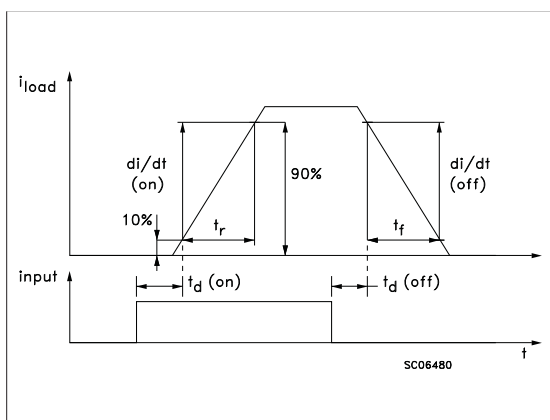

## FUNCTIONAL DESCRIPTION

The device has a diagnostic output which indicates open load conditions in off state as well as in on state, output shorted to  $V_{CC}$  and overtemperature. The truth table shows input, diagnostic and output voltage level in normal operation and in fault conditions. The output signals are processed by internal logic. The open load diagnostic output has a 5 ms filtering. The filter gives a continuous signal for the fault condition after an initial delay of about 5 ms. This means that a disconnection during normal operation, with a duration of less than 5 ms does not affect the status output. Equally, any re-connection of less than 5 ms during a disconnection duration does not affect the status output. No delay occur for the status to go low in case of overtemperature conditions. From the falling edge of the input signal the status output initially low in fault condition (over temperature or open load) will go back with a delay ( $t_{povl}$ ) in case of overtemperature condition and a delay ( $t_{pol}$ ) in case of open load. These feature fully comply with International Standard Office (I.S.O.) requirement for automotive High Side Driver.

To protect the device against short circuit and over current conditions, the thermal protection turns the integrated Power MOS off at a minimum junction temperature of 140 °C. When the temperature returns to 125 °C the switch is automatically turned on again. In short circuit the protection reacts with virtually no delay, the sensor being located in the region of the die where the heat is generated. Driving inductive loads, an internal function of the device ensures the fast demagnetization with a

typical voltage ( $V_{demag}$ ) of -18V.

This function allows to greatly reduce the power dissipation according to the formula:

$$P_{dem} = 0.5 \cdot L_{load} \cdot (I_{load})^2 \cdot [(V_{CC} + V_{demag}) / V_{demag}] \cdot f$$

where  $f$  = switching frequency and

$V_{demag}$  = demagnetization voltage

Based on this formula it is possible to know the value of inductance and/or current to avoid a thermal shut-down. The maximum inductance which causes the chip temperature to reach the shut down temperature in a specific thermal environment, is in fact a function of the load current for a fixed  $V_{CC}$ ,  $V_{demag}$  and  $f$ .

## PROTECTING THE DEVICE AGAINST LOAD DUMP - TEST PULSE 5

The device is able to withstand the test pulse No. 5 at level II ( $V_s = 46.5V$ ) according to the ISO T/R 7637/1 without any external component. This means that all functions of the device are performed as designed after exposure to disturbance at level II. The VN06SP is able to withstand the test pulse No.5 at level III adding an external resistor of 150 ohm between GND pin and ground plus a filter capacitor of 1000  $\mu F$  between  $V_{CC}$  pin and ground (if  $R_{LOAD} \leq 20 \Omega$ ).

## PROTECTING THE DEVICE AGAINST REVERSE BATTERY

The simplest way to protect the device against a continuous reverse battery voltage (-26V) is to insert a Schottky diode between GND pin and ground, as shown in the typical application circuit (fig.3).

The consequences of the voltage drop across this diode are as follows:

If the input is pulled to power GND, a negative voltage of  $-V_f$  is seen by the device. ( $V_{il}$ ,  $V_{ih}$  thresholds and  $V_{stat}$  are increased by  $V_f$  with respect to power GND).

The undervoltage shutdown level is increased by  $V_f$ .

If there is no need for the control unit to handle external analog signals referred to the power GND, the best approach is to connect the reference potential of the control unit to node [6] (see application circuit in fig. 4), which becomes the common signal GND for the whole control board avoiding shift of  $V_{ih}$ ,  $V_{il}$  and  $V_{stat}$ . This solution allows the use of a standard diode.

TRUTH TABLE

	INPUT	OUTPUT	DIAGNOSTIC
Normal Operation	L	L	H
	H	H	H
Open Circuit (No Load)	H	H	L
Over-temperature	H	L	L
Under-voltage	X	L	H
Short load to V <sub>CC</sub>	L	H	L

Figure 1: Waveforms

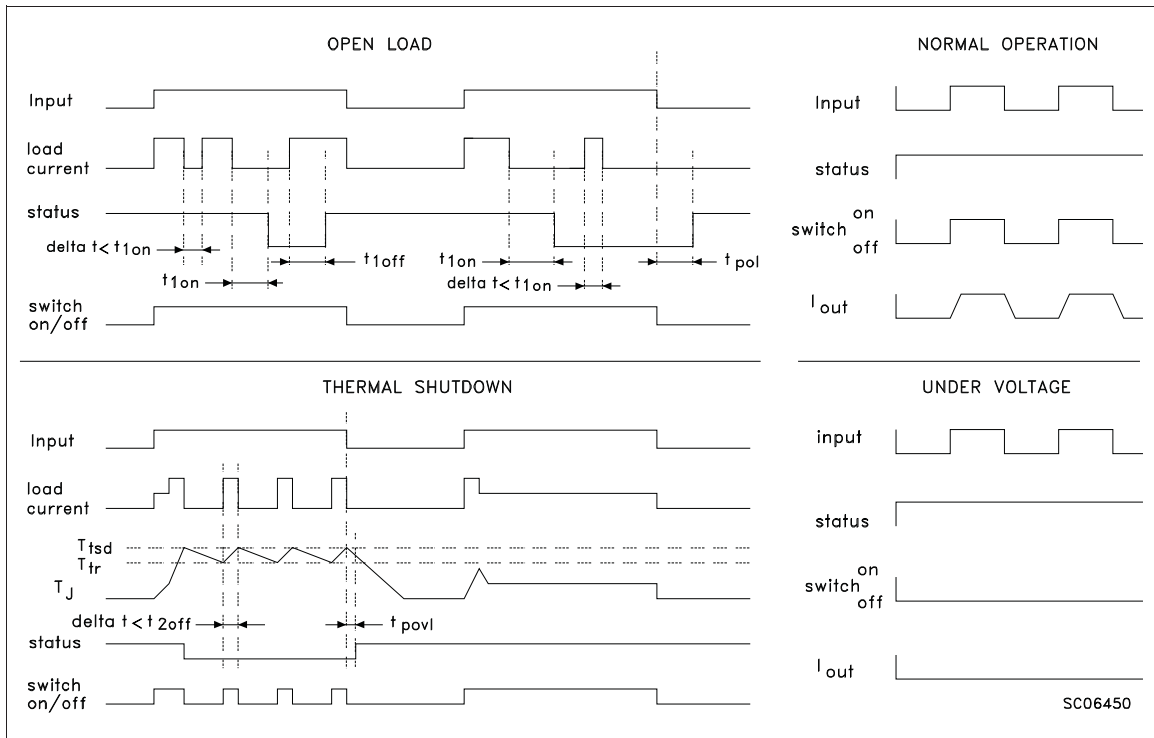
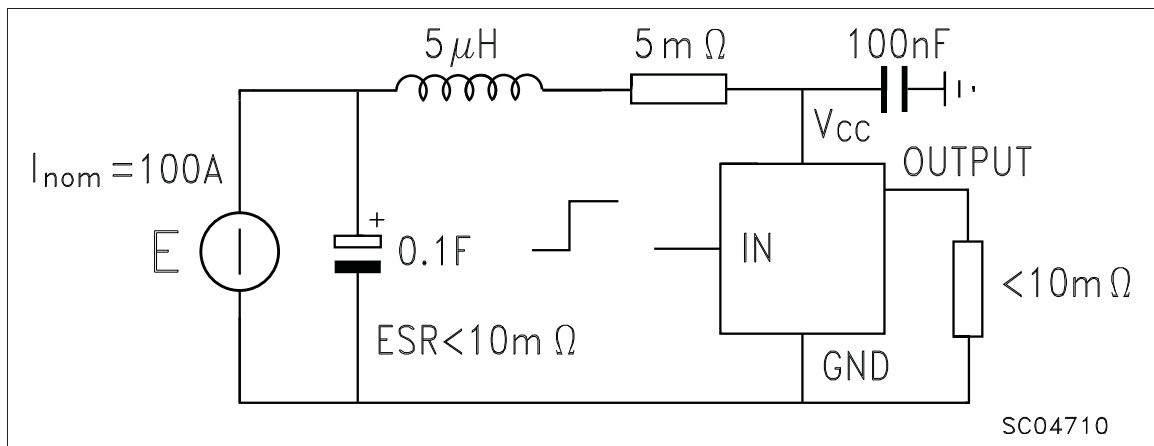
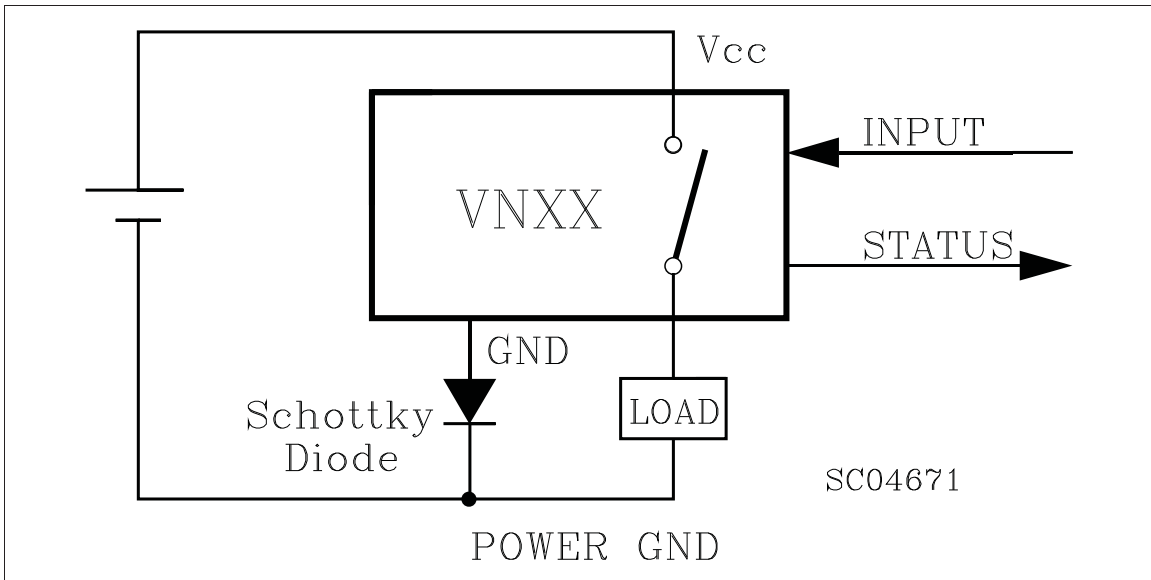

Figure 2: Over Current Test Circuit



**Figure 3:** Typical Application Circuit With A Schottky Diode For Reverse Supply Protection



**Figure 4:** Typical Application Circuit With Separate Signal Ground

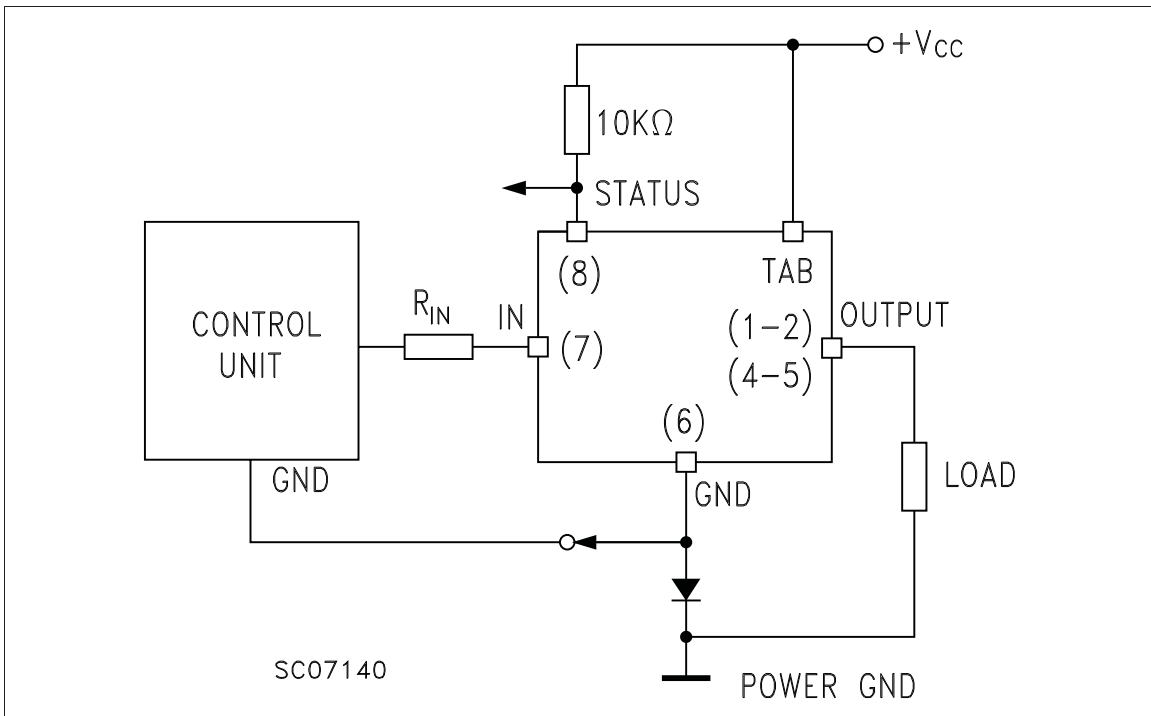



**PowerSO-10 MECHANICAL DATA**

DIM.	mm			inch		
	MIN.	TYP.	MAX.	MIN.	TYP.	MAX.
A	3.35		3.65	0.132		0.144
A1	0.00		0.10	0.000		0.004
B	0.40		0.60	0.016		0.024
c	0.35		0.55	0.013		0.022
D	9.40		9.60	0.370		0.378
D1	7.40		7.60	0.291		0.300
E	9.30		9.50	0.366		0.374
E1	7.20		7.40	0.283		0.291
E2	7.20		7.60	0.283		0.300
E3	6.10		6.35	0.240		0.250
E4	5.90		6.10	0.232		0.240
e		1.27			0.050	
F	1.25		1.35	0.049		0.053
H	13.80		14.40	0.543		0.567
h		0.50			0.002	
L	1.20		1.80	0.047		0.071
q		1.70			0.067	
$\alpha$	0°		8°			

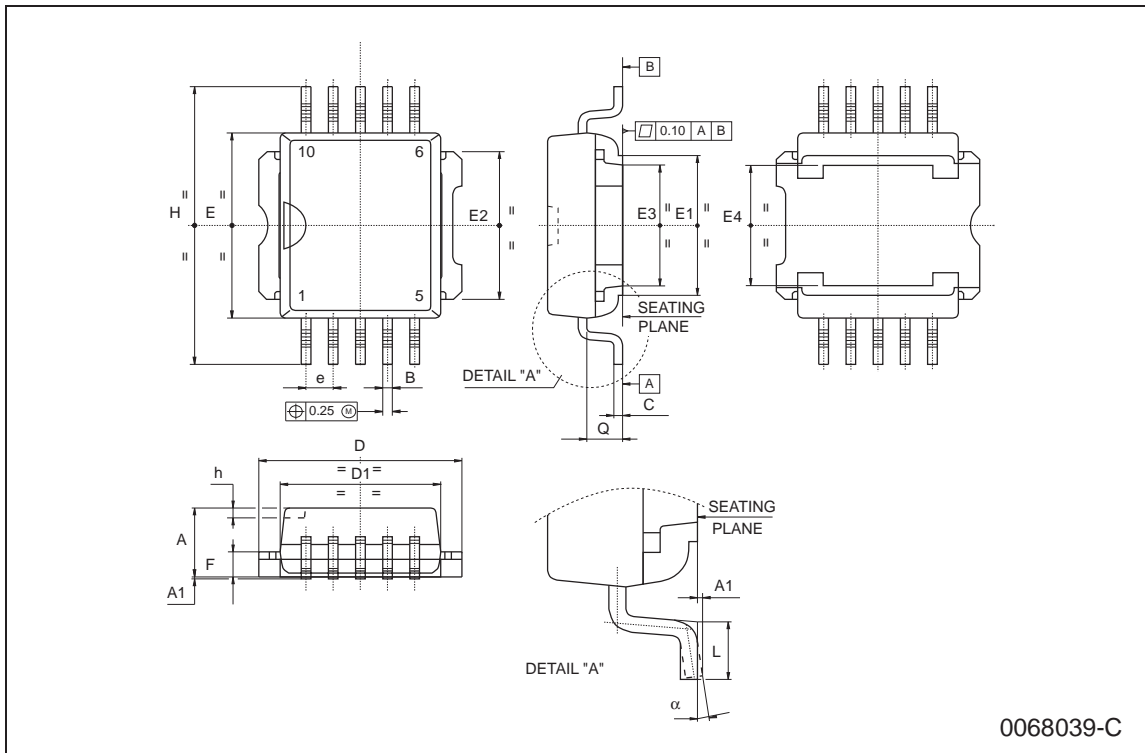

**Please Read Carefully:**

Information in this document is provided solely in connection with ST products. STMicroelectronics NV and its subsidiaries ("ST") reserve the right to make changes, corrections, modifications or improvements, to this document, and the products and services described herein at any time, without notice.

All ST products are sold pursuant to ST's terms and conditions of sale.

Purchasers are solely responsible for the choice, selection and use of the ST products and services described herein, and ST assumes no liability whatsoever relating to the choice, selection or use of the ST products and services described herein.

No license, express or implied, by estoppel or otherwise, to any intellectual property rights is granted under this document. If any part of this document refers to any third party products or services it shall not be deemed a license grant by ST for the use of such third party products or services, or any intellectual property contained therein or considered as a warranty covering the use in any manner whatsoever of such third party products or services or any intellectual property contained therein.

**UNLESS OTHERWISE SET FORTH IN ST'S TERMS AND CONDITIONS OF SALE ST DISCLAIMS ANY EXPRESS OR IMPLIED WARRANTY WITH RESPECT TO THE USE AND/OR SALE OF ST PRODUCTS INCLUDING WITHOUT LIMITATION IMPLIED WARRANTIES OF MERCHANTABILITY, FITNESS FOR A PARTICULAR PURPOSE (AND THEIR EQUIVALENTS UNDER THE LAWS OF ANY JURISDICTION), OR INFRINGEMENT OF ANY PATENT, COPYRIGHT OR OTHER INTELLECTUAL PROPERTY RIGHT.**

**ST PRODUCTS ARE NOT DESIGNED OR AUTHORIZED FOR USE IN: (A) SAFETY CRITICAL APPLICATIONS SUCH AS LIFE SUPPORTING, ACTIVE IMPLANTED DEVICES OR SYSTEMS WITH PRODUCT FUNCTIONAL SAFETY REQUIREMENTS; (B) AERONAUTIC APPLICATIONS; (C) AUTOMOTIVE APPLICATIONS OR ENVIRONMENTS, AND/OR (D) AEROSPACE APPLICATIONS OR ENVIRONMENTS. WHERE ST PRODUCTS ARE NOT DESIGNED FOR SUCH USE, THE PURCHASER SHALL USE PRODUCTS AT PURCHASER'S SOLE RISK, EVEN IF ST HAS BEEN INFORMED IN WRITING OF SUCH USAGE, UNLESS A PRODUCT IS EXPRESSLY DESIGNATED BY ST AS BEING INTENDED FOR "AUTOMOTIVE, AUTOMOTIVE SAFETY OR MEDICAL" INDUSTRY DOMAINS ACCORDING TO ST PRODUCT DESIGN SPECIFICATIONS. PRODUCTS FORMALLY ESCC, QML OR JAN QUALIFIED ARE DEEMED SUITABLE FOR USE IN AEROSPACE BY THE CORRESPONDING GOVERNMENTAL AGENCY.**

Resale of ST products with provisions different from the statements and/or technical features set forth in this document shall immediately void any warranty granted by ST for the ST product or service described herein and shall not create or extend in any manner whatsoever, any liability of ST.

ST and the ST logo are trademarks or registered trademarks of ST in various countries.

Information in this document supersedes and replaces all information previously supplied.

The ST logo is a registered trademark of STMicroelectronics. All other names are the property of their respective owners.

© 2013 STMicroelectronics - All rights reserved

STMicroelectronics group of companies

Australia - Belgium - Brazil - Canada - China - Czech Republic - Finland - France - Germany - Hong Kong - India - Israel - Italy - Japan - Malaysia - Malta - Morocco - Philippines - Singapore - Spain - Sweden - Switzerland - United Kingdom - United States of America

[www.st.com](http://www.st.com)