

阅读申明

- 1.本站收集的数据手册和产品资料都来自互联网，版权归原作者所有。如读者和版权方有任何异议请及时告之，我们将妥善解决。
- 2.本站提供的中文数据手册是英文数据手册的中文翻译，其目的是协助用户阅读，该译文无法自动跟随原稿更新，同时也可能存在翻译上的不当。建议读者以英文原稿为参考以便获得更精准的信息。
- 3.本站提供的产品资料，来自厂商的技术支持或者使用者的心得体会等，其内容可能存在描述上的差异，建议读者做出适当判断。
- 4.如需与我们联系，请发邮件到marketing@iczoom.com，主题请标有“数据手册”字样。

Read Statement

1. The datasheets and other product information on the site are all from network reference or other public materials, and the copyright belongs to the original author and original published source. If readers and copyright owners have any objections, please contact us and we will deal with it in a timely manner.
2. The Chinese datasheets provided on the website is a Chinese translation of the English datasheets. Its purpose is for reader's learning exchange only and do not involve commercial purposes. The translation cannot be automatically updated with the original manuscript, and there may also be improper translations. Readers are advised to use the English manuscript as a reference for more accurate information.
3. All product information provided on the website refer to solutions from manufacturers' technical support or users the contents may have differences in description, and readers are advised to take the original article as the standard.
4. If you have any questions, please contact us at marketing@iczoom.com and mark the subject with "Datasheets" .



VB921ZVFI VB921ZVSP

HIGH VOLTAGE IGNITION COIL DRIVER POWER I.C.

TYPE	V_{cl}	I_{cl}	$V_{cg(sat)}$
VB921ZVFI	340V	7.5A	2.5V
VB921ZVSP			

- NO EXTERNAL COMPONENT REQUIRED
- INTEGRATED HIGH VOLTAGE CLAMP
- COIL CURRENT LIMIT INTERNALLY SET
- HIGH RUGGEDNESS

DESCRIPTION

The VB921ZVFI, VB921ZVSP is a monolithic high voltage integrated circuit made using the STMicroelectronics VIPower™ M1-2 technology, which combines a vertical current flow power transistor with a coil current limiting circuit and a collector voltage clamping. The device is particularly suitable for application in high performance electronic car ignition, where coil current limitation and voltage clamping are required.

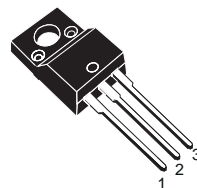

ISOWATT220

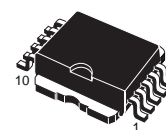

PowerSO-10™

ORDER CODES:

ISOWATT220 VB921ZVFI
POWERSO-10™ VB921ZVSP

BLOCK DIAGRAM

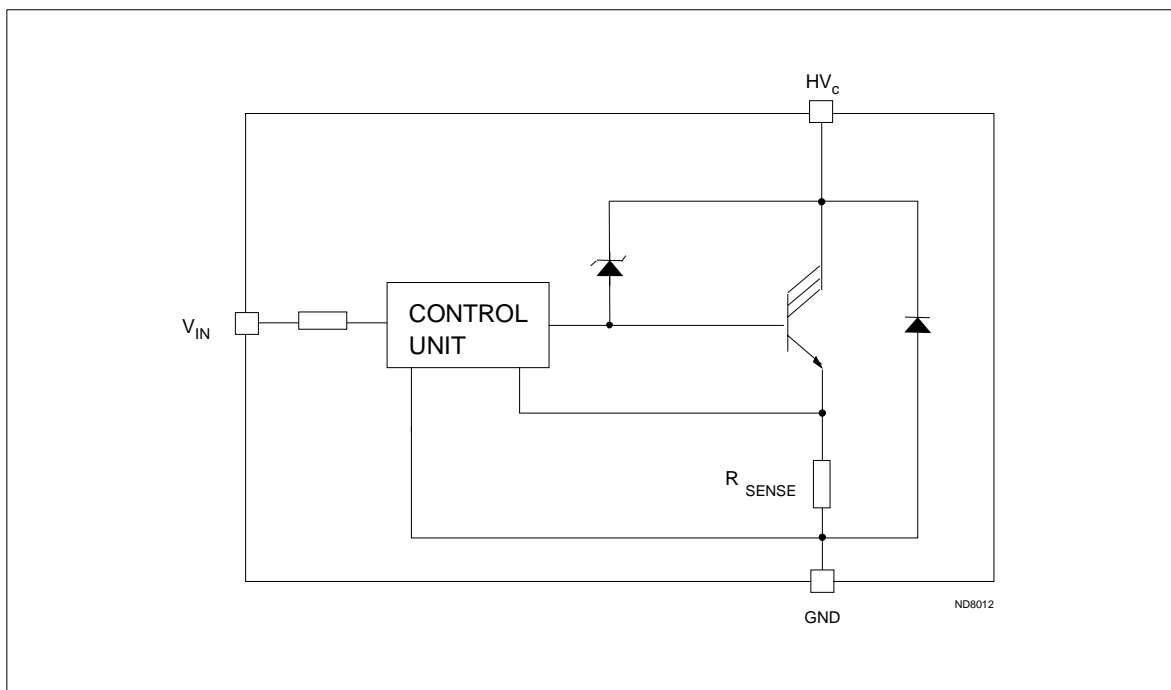

VB921ZVFI / VB921ZVSP

ABSOLUTE MAXIMUM RATING

Symbol	Parameter	Value		Unit
		ISOWATT220	PowerSO-10	
HV_C	Collector Voltage	Internally limited		V
I_C	Collector Current	Internally limited		A
V_{IN}	Maximum Input Voltage	8		V
I_{IN}	Input current	10		mA
P_{tot}	Total dissipation at $T_C=25^\circ\text{C}$	40	100	W
T_j	Junction operating temperature	- 40 to 150		$^\circ\text{C}$
T_{stg}	Storage temperature	- 40 to 150		$^\circ\text{C}$

THERMAL DATA

Symbol	Parameter	Value		Unit
		ISOWATT220	PowerSO-10	
$R_{thj-case}$	Thermal resistance junction-case (MAX)	3.12	1.25	$^\circ\text{C}/\text{W}$
$R_{thj-amb}$	Thermal resistance junction-ambient (MAX)	62.5	62.5	$^\circ\text{C}/\text{W}$

CONNECTION DIAGRAM (TOP VIEW)

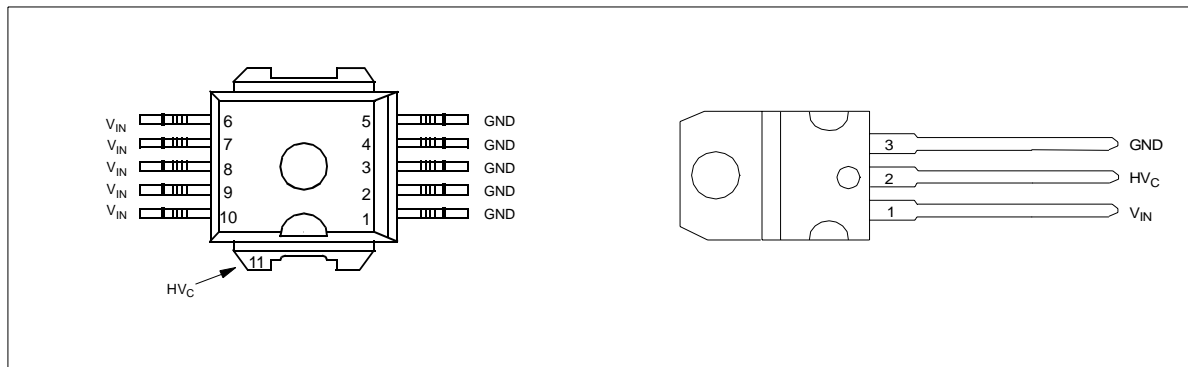

ELECTRICAL CHARACTERISTICS ($V_{CC}=12\text{V}$; $T_{case}=25^\circ\text{C}$ unless otherwise specified)

Symbol	Parameter	Test Conditions	Min	Typ	Max	Unit
V_{IN}	Input Voltage		4.2		5.5	V
I_{IN}	Input Current	$V_{IN}=4.2\text{V}$; $I_C=5\text{A}$ (See test circuit) $V_{IN}=5\text{V}$; $I_C=5\text{A}$			5 10	mA mA
I_{cgo}	Collector Cut-off Current	$V_{IN}=0\text{V}$; $HV_C=250\text{V}$			250	μA
$V_{cl} (*)$	High voltage clamp	$-40^\circ\text{C} < T_j < 125^\circ\text{C}$	340		440	V
$I_{cl} (*)$	Coil Current Limit	$V_{IN}=4.2\text{V}$; $-40^\circ\text{C} < T_j < 125^\circ\text{C}$ $V_{IN}=5\text{V}$; $-40^\circ\text{C} < T_j < 125^\circ\text{C}$ (See note 1)	6 6.5		7.5	A A
$V_{cg(sat)}$	Power Stage Saturation Voltage	$I_C=5\text{A}$; $I_{IN}=10\text{mA}$			2.5	V
$V_f (**)$	Diode Forward Voltage	$I_f=10\text{A}$			3.5	V
ΔI_{cl}	Coil current variation in respect to $V_{IN}=5\text{V}$	$V_{IN}=4.5 \div 5.5\text{V}$			200	mA

(*) Coil data: primary resistance $R_C=0.4 \div 0.8\Omega$, primary inductance $L_C=6 \div 8\text{mH}$

(**) Pulsed: pulse duration= 300 μs , duty cycle=1.5%

NOTE 1: I_{cl} is also controlled in respect to the variation of V_{IN} between 4.5 and 5.5V

FIGURE 1: Delay-off time Vs Temperature

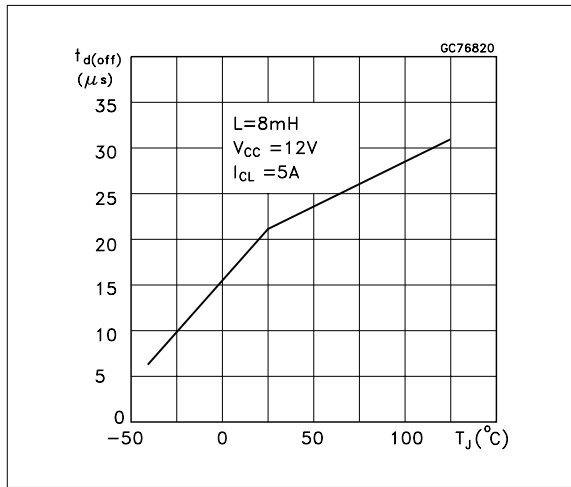

FIGURE 3: Saturation Voltage VS Collector Current

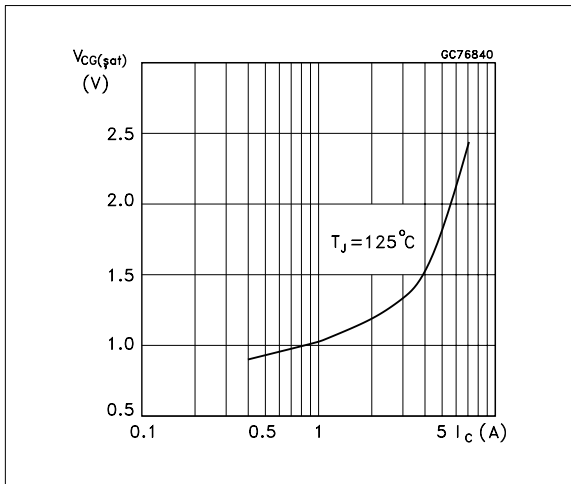

FIGURE 5: Coil Current Limit Vs Temperature

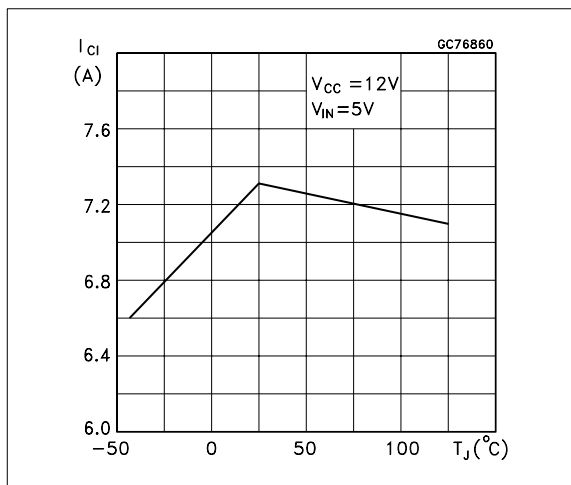

FIGURE 2: Input current Vs Temperature

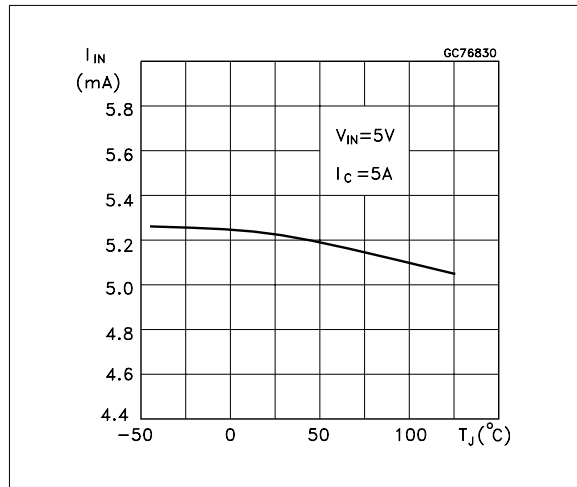

FIGURE 4: Diode Forward Voltage VS Temperature

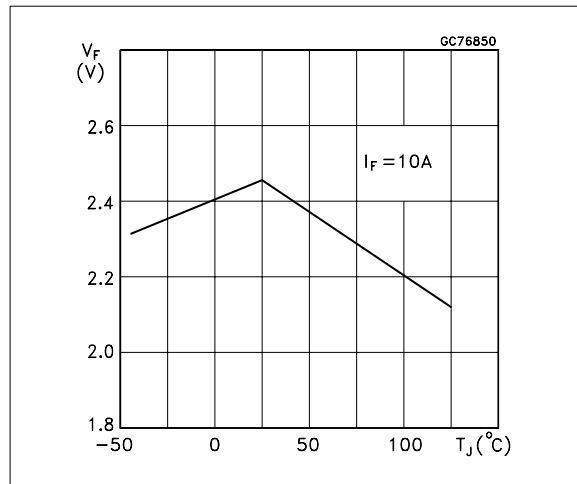
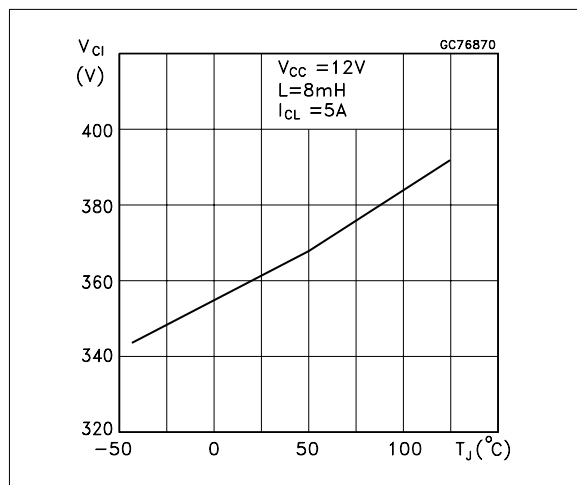
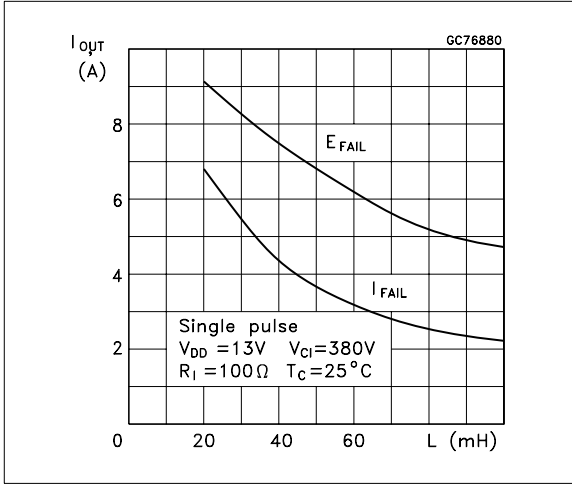

FIGURE 6: Clamping Voltage VS Temperature



VB921ZVFI / VB921ZVSP

FIGURE 7: Maximum Energy and Output Current Unclamped



PowerSO-10™ MECHANICAL DATA

DIM.	mm.			inch		
	MIN.	TYP	MAX.	MIN.	TYP.	MAX.
A	3.35		3.65	0.132		0.144
A1	0.00		0.10	0.000		0.004
B	0.40		0.60	0.016		0.024
c	0.35		0.55	0.013		0.022
D	9.40		9.60	0.370		0.378
D1	7.40		7.60	0.291		0.300
E	9.30		9.50	0.366		0.374
E1	7.20		7.40	0.283		0.291
E2	7.20		7.60	0.283		300
E3	6.10		6.35	0.240		0.250
E4	5.90		6.10	0.232		0.240
e		1.27			0.050	
F	1.25		1.35	0.049		0.053
H	13.80		14.40	0.543		0.567
h		0.50			0.002	
Q		1.70			0.067	
α	0°		8°			

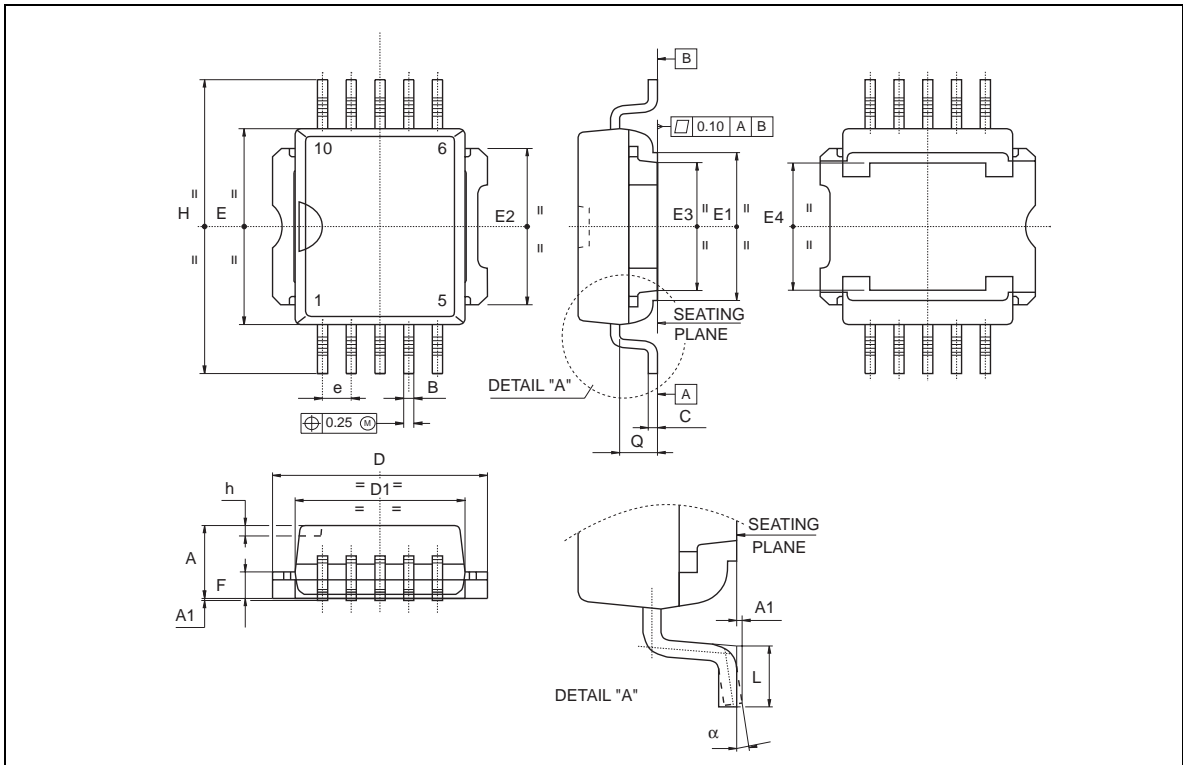

ISOWATT220 MECHANICAL DATA

DIM.	mm.			inch		
	MIN.	TYP	MAX.	MIN.	TYP.	MAX.
A	4.4		4.6	0.173		0.181
B	2.5		2.7	0.098		0.106
D	2.5		2.75	0.098		0.108
E	0.4		0.7	0.015		0.027
F	0.75		1	0.030		0.039
F1	1.15		1.7	0.045		0.067
F2	1.15		1.7	0.045		0.067
G	4.95		5.2	0.195		0.204
G1	2.4		2.7	0.094		0.106
H	10		10.4	0.393		0.409
L2		16			0.630	
L3	28.6		30.6	1.126		1.204
L4	9.8		10.6	0.385		0.417
L6	15.9		16.4	0.626		0.645
L7	9		9.3	0.354		0.366
	3		3.2	0.118		0.126

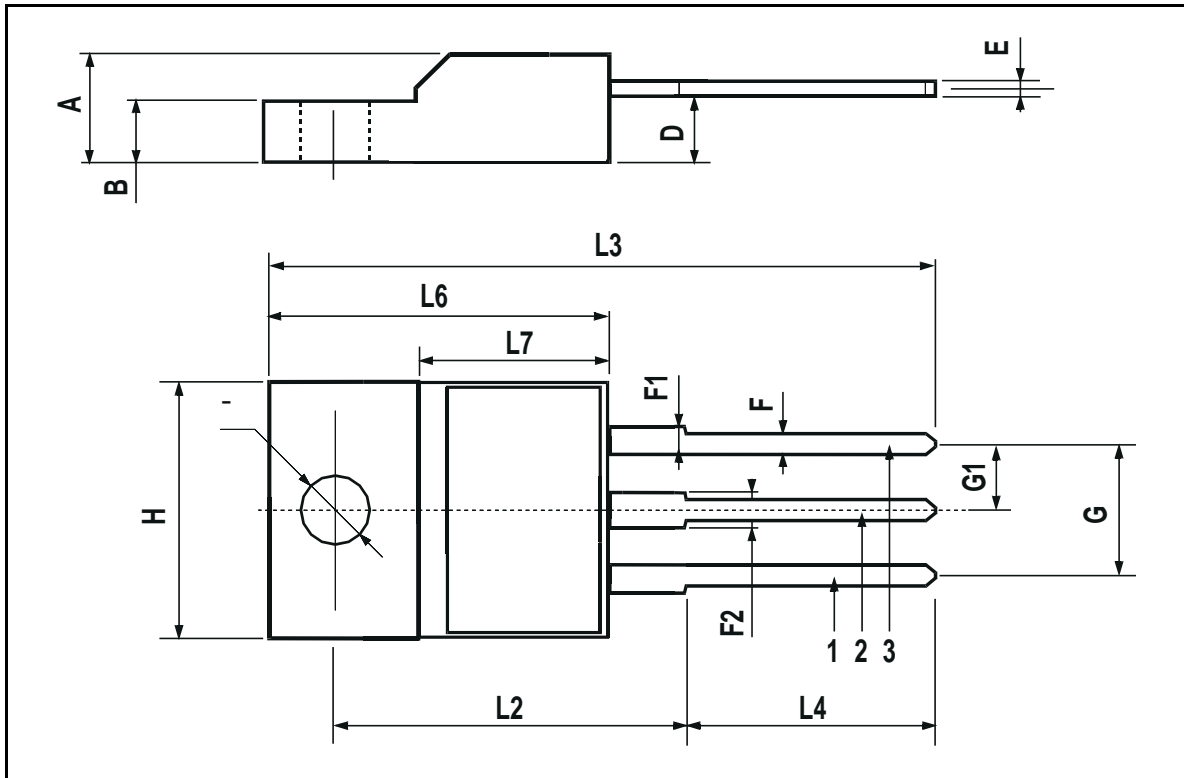

Information furnished is believed to be accurate and reliable. However, STMicroelectronics assumes no responsibility for the consequences of use of such information nor for any infringement of patents or other rights of third parties which may result from its use. No license is granted by implication or otherwise under any patent or patent rights of STMicroelectronics. Specifications mentioned in this publication are subject to change without notice. This publication supersedes and replaces all information previously supplied. STMicroelectronics products are not authorized for use as critical components in life support devices or systems without express written approval of STMicroelectronics.

The ST logo is a registered trademark of STMicroelectronics

© 2000 STMicroelectronics - Printed in ITALY- All Rights Reserved.

STMicroelectronics GROUP OF COMPANIES

Australia - Brazil - China - Finland - France - Germany - Hong Kong - India - Italy - Japan - Malaysia - Malta -
Morocco - Singapore - Spain - Sweden - Switzerland - United Kingdom - U.S.A.

<http://www.st.com>