

阅读申明

- 1.本站收集的数据手册和产品资料都来自互联网，版权归原作者所有。如读者和版权方有任何异议请及时告之，我们将妥善解决。
- 2.本站提供的中文数据手册是英文数据手册的中文翻译，其目的是协助用户阅读，该译文无法自动跟随原稿更新，同时也可能存在翻译上的不当。建议读者以英文原稿为参考以便获得更精准的信息。
- 3.本站提供的产品资料，来自厂商的技术支持或者使用者的心得体会等，其内容可能存在描述上的差异，建议读者做出适当判断。
- 4.如需与我们联系，请发邮件到marketing@iczoom.com，主题请标有“数据手册”字样。

Read Statement

1. The datasheets and other product information on the site are all from network reference or other public materials, and the copyright belongs to the original author and original published source. If readers and copyright owners have any objections, please contact us and we will deal with it in a timely manner.
2. The Chinese datasheets provided on the website is a Chinese translation of the English datasheets. Its purpose is for reader's learning exchange only and do not involve commercial purposes. The translation cannot be automatically updated with the original manuscript, and there may also be improper translations. Readers are advised to use the English manuscript as a reference for more accurate information.
3. All product information provided on the website refer to solutions from manufacturers' technical support or users the contents may have differences in description, and readers are advised to take the original article as the standard.
4. If you have any questions, please contact us at marketing@iczoom.com and mark the subject with "Datasheets" .

CS8240

500 mA High Side (PNP) Driver with On-Chip Flyback Diode

The CS8240 is a fast, PNP high side driver capable of delivering up to 500 mA into a resistive or inductive load in harsh automotive or industrial environments. An internal flyback diode clamp is incorporated for inductive loads. The input (V_{IN}) is TTL and CMOS compatible and has hysteresis to minimize the effects of noise. When the input is high, the output is on. When the input is low, the output is off and the supply voltage quiescent current is very low ($< 1.0 \mu\text{A}$, typ). For device protection, the CS8240 incorporates thermal shutdown, short circuit current limiting, overvoltage shutdown, and reverse battery protection. The CS8240 can withstand supply voltage transients of 60 V (min) and -50 V.

The CS8240 is available in an overmolded 5 lead TO-220 package and is a competitive replacement for the LM-1921, LM-1951, LM-1952, MC-3399, and L-9350.

Features

- Low Output Saturation Voltage
 - 0.22 V at $I_{OUT} = 125$ mA
 - 0.33 V at $I_{OUT} = 225$ mA
- Overmolded Package
- On-Chip Flyback Diode
- Fault Protection
 - Over Voltage Shutdown (32 V, typ)
 - Thermal Shutdown (165°C , typ)
 - Short Circuit Limiting (1.1 A typ)
 - -50 V Reverse Transient Protection
 - 60 V Load Dump Protection
 - Reverse Battery
- Low Quiescent Current (Off State)
- ESD Protected

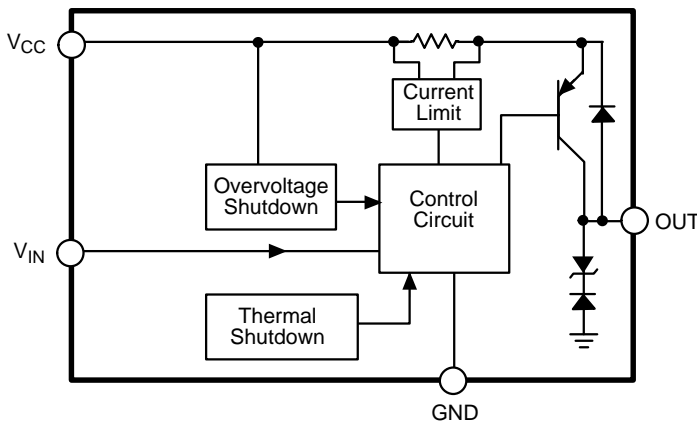
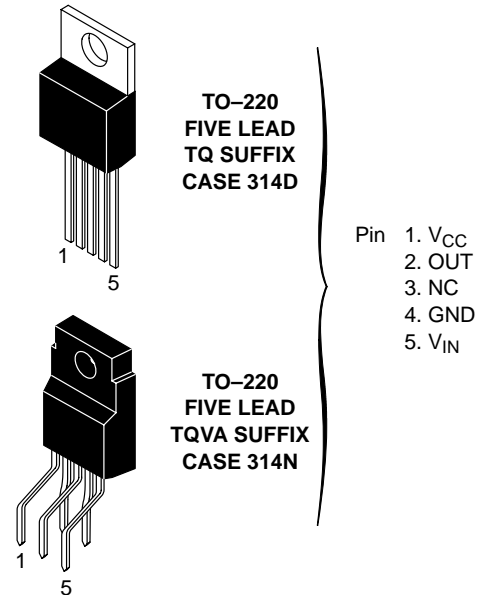

Figure 1. Block Diagram



ON Semiconductor™

<http://onsemi.com>



MARKING DIAGRAM

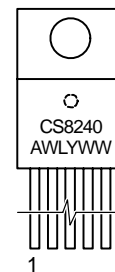

A = Assembly Location
 WL, L = Wafer Lot
 YY, Y = Year
 WW, W = Work Week

ORDERING INFORMATION

Device	Package	Shipping
CS8240YTQ5	TO-220 FIVE LEAD STRAIGHT	50 Units/Rail
CS8240YTQVA5	TO-220 FIVE LEAD VERTICAL	50 Units/Rail

CS8240

MAXIMUM RATINGS*

Rating	Value	Unit	
Supply Voltage	6.0 to 26	V	
Overshoot Protection	60	V	
Reverse Voltage:	DC Transient	-16 -50	V V
Internal Power Dissipation	Internally limited	-	
Logic Input Voltage	-0.3 to +7.0	V	
Junction Temperature Range, T_J	-40 to 150	°C	
Storage Temperature Range, T_S	-55 to +165	°C	
Lead Temperature Soldering:	Wave Solder (through hole styles only) (Note 1)	260 peak	°C
Electrostatic Discharge (Human Body Model)	2.0	kV	

1. 10 second maximum.

*The maximum package power dissipation must be observed.

ELECTRICAL CHARACTERISTICS ($-40^{\circ}\text{C} \leq T_A \leq 125^{\circ}\text{C}$; $-40^{\circ}\text{C} \leq T_J \leq 150^{\circ}\text{C}$, unless otherwise specified.)

Characteristic	Test Conditions	Min	Typ	Max	Unit
General Characteristics					
Operating Supply Voltage	-	6.0	-	-	V
Quiescent Current	$V_{CC} = 12\text{V}$, $V_{IN} \leq V_{IN(Low)}$	-	1.0	100	μA
	$V_{IN} \geq V_{IN(HI)}$, $R_{LOAD} = 50\ \Omega$	-	16	30	mA
	$6.0\text{V} \leq V_{CC} \leq 20\text{V}$ $20\text{V} \leq V_{CC} \leq 24\text{V}$	-	25	50	mA
Output Stage					
Output Saturation Voltage	$V_{IN} \leq V_{IN(HI)}$, $V_{CC} = 6.0\text{V}$, $I_{LOAD} = 125\text{mA}$	-	0.22	0.5	V
	$V_{CC} = 14\text{V}$, $I_{LOAD} = 225\text{mA}$	-	0.33	0.7	V
Output Leakage Current	Input $\leq V_{IN(L)}$, $V_{CC} = 12\text{V}$, $V_{OUT} = 0\text{V}$	-	1.0	150	μA
Negative Output Clamp	$I_{CLAMP} = 100\text{mA}$, $V_{CC} = 12\text{V}$	-18	-15.5	-12	V
Turn On Delay Time	$V_{CC} = 12\text{V}$, $I_{LOAD} = 150\text{mA}$	-	5.0	20	μs
Turn Off Delay Time	$V_{CC} = 12\text{V}$, $I_{LOAD} = 150\text{mA}$	-	5.0	20	μs
Input Stage					
Input Voltage	Logic = High, $V_{CC} = 12\text{V}$ Turn ON	0.8	1.45	-	V
	Logic = Low, $V_{CC} = 12\text{V}$ Turn OFF	-	1.2	2.0	V
Input Current	$V_{IN} = 5.5\text{V}$	-	100	200	μA
	$V_{IN} = 0.8\text{V}$	-	15	50	μA
Protection Circuitry					
Overshoot Shutdown	$V_{IN} \geq V_{IN(HI)}$	26	32	-	V
Output Short Circuit Current	$V_{IN} \geq V_{IN(HI)}$, $V_{CC} = 12\text{V}$, $V_{OUT} = 0\text{V}$	0.55	1.1	2.5	A
Thermal Shutdown	-	150	165	-	°C

PACKAGE PIN DESCRIPTION

PACKAGE PIN #	PIN SYMBOL	FUNCTION
5 Lead TO-220		
1	V_{CC}	Supply Voltage to the IC. Supplies load current through PNP.
2	OUT	Collector of output PNP, current to load is sourced from this lead.
3	NC	No connection.
4	GND	Ground.
5	V_{IN}	Input voltage to control output. Logic high turns output on. Logic low turns output off.

TYPICAL PERFORMANCE CHARACTERISTICS

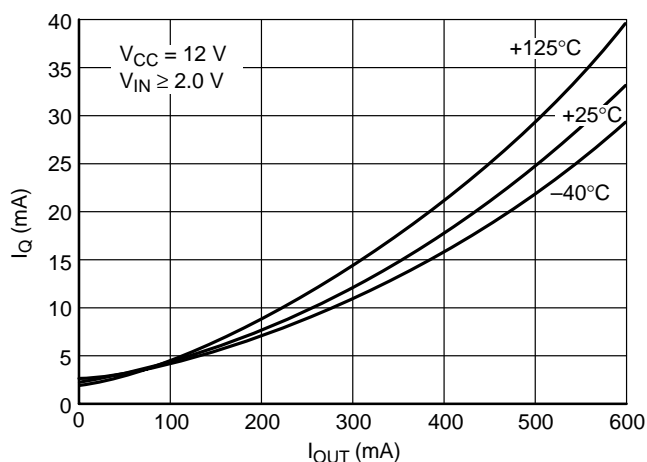

Figure 2. Quiescent Current vs. I_{OUT}

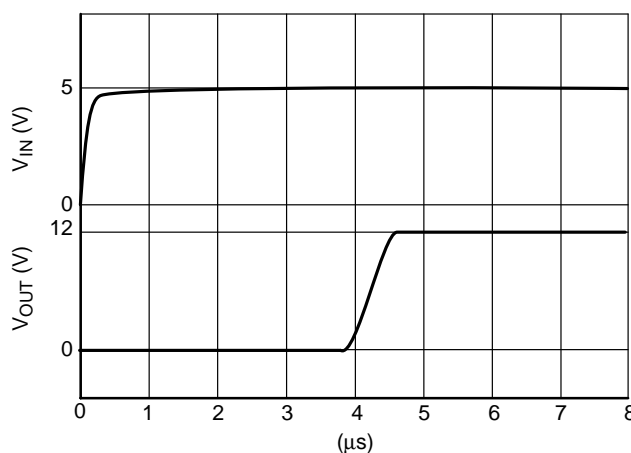

Figure 3. Turn-On Delay Time

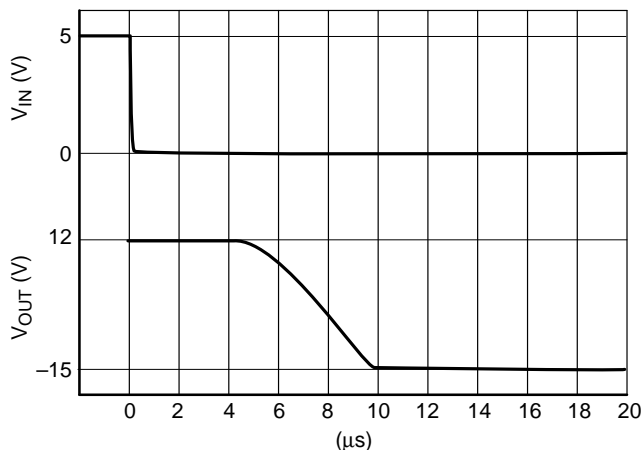

Figure 4. Turn Off Delay Time

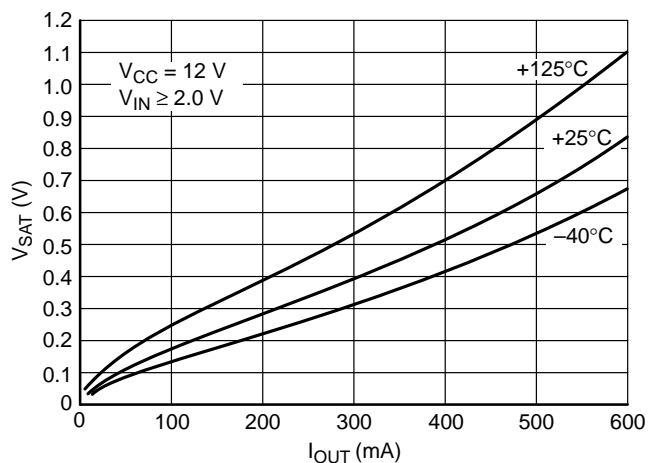

Figure 5. Output Saturation Voltage vs. I_{OUT}

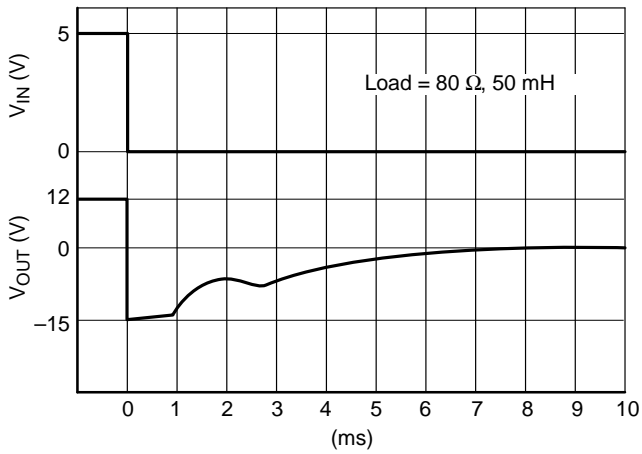

Figure 6. Flyback Clamp Characteristics

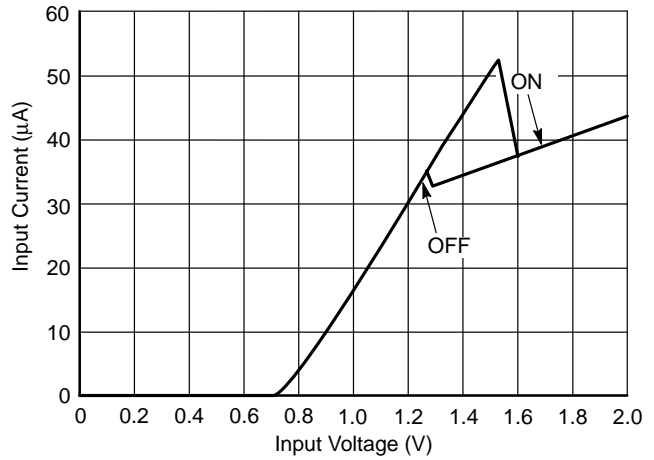

Figure 7. I_{IN} vs. V_{IN}

CIRCUIT DESCRIPTION

Input Stage

The input stage is a self biased band gap based circuit with a positive going trip point of 1.45 V (typ) and a negative going trip point of 1.20 V (typ) (250 mV of hysteresis). When the input voltage is below the positive trip point, the quiescent current of the supply voltage line is less than 1.0 μA , (typ). When the input voltage exceeds the positive trip point (1.45 V, typ), the input stage “wakes up” the rest of the CS8240 circuitry and turns on the output stage.

Output Stage

The output stage is built around a high current PNP output transistor. A control amplifier monitors the saturation voltage of the output PNP and maintains a balance of low saturation voltage and minimum base drive to the PNP for

the given output current. The base drive of the PNP is the dominant component of the quiescent current of the CS8240 and is dependent on the level of output current.

Short circuit protection (1.1 A, typ) is also incorporated in the output stage.

Protection Circuitry

In addition to the short circuit protection mentioned above, the CS8240 also incorporates a thermal shutdown circuit (165°C, typ) and a high voltage shutdown circuit (33 V, typ), both of which cut off the drive to the PNP output transistor when excessive current is drawn. Inherent in the design of the CS8240 is transient protection to +60 V and -50 V on the supply line. The CS8240 is ESD protected in excess of 2.0 kV (Human Body Model).

CS8240

TYPICAL APPLICATION CIRCUITS

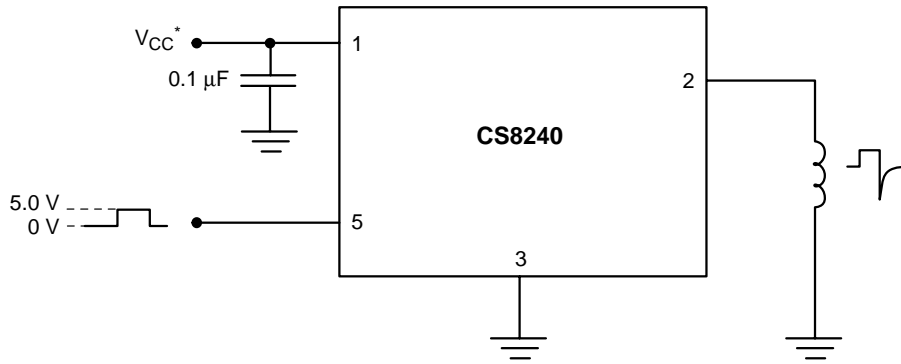

Figure 8. Solenoid Driver

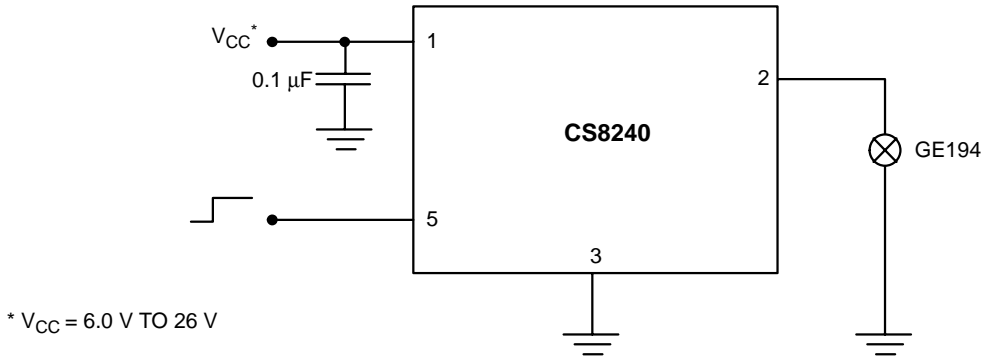

Figure 9. Lamp Driver

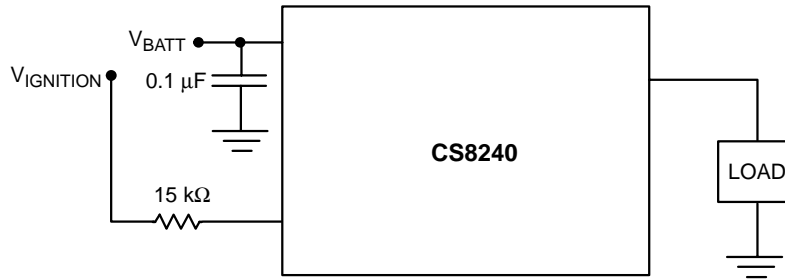
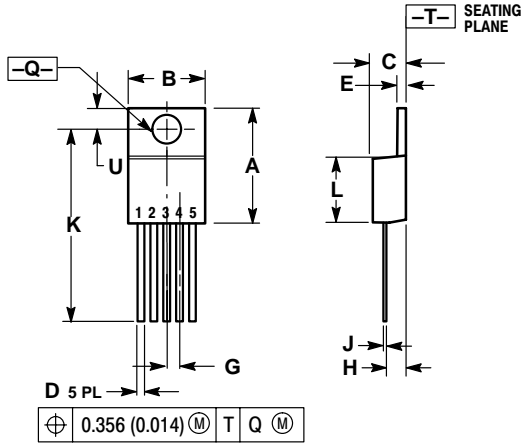

Figure 10. Controlled High Side Switch

CS8240

PACKAGE DIMENSIONS

TO-220
FIVE LEAD
TQ SUFFIX
CASE 314D-04
ISSUE E



NOTES:

1. DIMENSIONING AND TOLERANCING PER ANSI Y14.5M, 1982.
2. CONTROLLING DIMENSION: INCH.
3. DIMENSION D DOES NOT INCLUDE INTERCONNECT BAR (DAMBAR) PROTRUSION. DIMENSION D INCLUDING PROTRUSION SHALL NOT EXCEED 10.92 (0.043) MAXIMUM.

DIM	INCHES		MILLIMETERS	
	MIN	MAX	MIN	MAX
A	0.572	0.613	14.529	15.570
B	0.390	0.415	9.906	10.541
C	0.170	0.180	4.318	4.572
D	0.025	0.038	0.635	0.965
E	0.048	0.055	1.219	1.397
G	0.067 BSC		1.702 BSC	
H	0.087	0.112	2.210	2.845
J	0.015	0.025	0.381	0.635
K	0.990	1.045	25.146	26.543
L	0.320	0.365	8.128	9.271
Q	0.140	0.153	3.556	3.886
U	0.105	0.117	2.667	2.972

TO-220
FIVE LEAD
TQVA SUFFIX
CASE 314N-01
ISSUE O

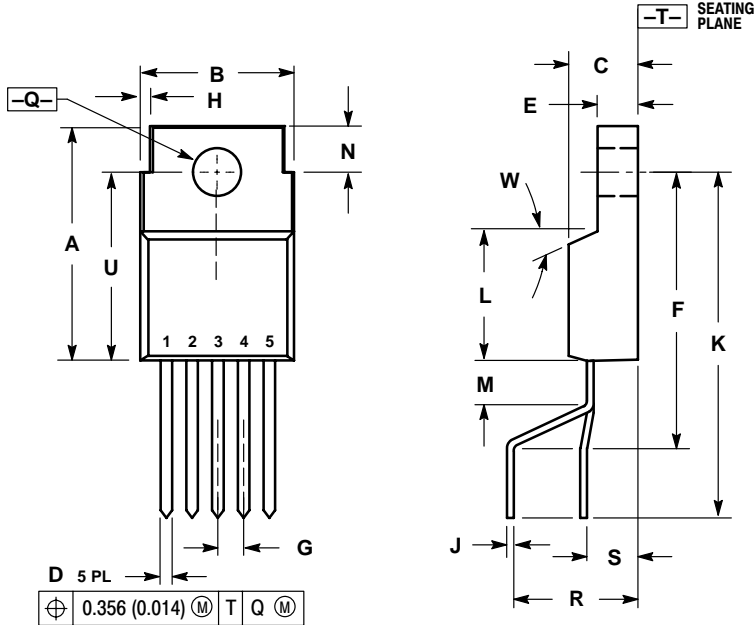

NOTES:

1. DIMENSIONING AND TOLERANCING PER ANSI Y14.5M, 1982.
2. CONTROLLING DIMENSION: INCH.
3. DIMENSION D DOES NOT INCLUDE INTERCONNECT BAR (DAMBAR) PROTRUSION. DIMENSION D INCLUDING PROTRUSION SHALL NOT EXCEED 10.92 (0.043) MAXIMUM.
4. LEADS MAINTAIN A RIGHT ANGLE WITH RESPECT TO THE PACKAGE BODY TO WITHIN $\pm 0.015^\circ$.

DIM	INCHES		MILLIMETERS	
	MIN	MAX	MIN	MAX
A	0.604	0.614	15.34	15.60
B	0.395	0.405	10.03	10.29
C	0.175	0.185	4.44	4.70
D	0.027	0.037	0.69	0.94
E	0.100	0.110	2.54	2.79
F	0.712	0.727	18.08	18.47
G	0.067 BSC		1.70 BSC	
H	0.020	0.030	0.51	0.76
J	0.014	0.022	0.36	0.56
K	0.889	0.904	22.58	22.96
L	0.324	0.339	8.23	8.61
M	0.115	0.130	2.92	3.30
N	0.115	0.125	2.92	3.17
Q	0.120	0.130	3.05	3.30
R	0.292	0.342	7.42	8.69
S	0.133	0.183	3.38	4.65
U	0.480	0.495	12.19	12.57
W	5°		5°	

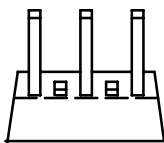

CS8240

PACKAGE THERMAL DATA

Parameter		TO-220, Five Lead	Unit
R _{θJC}	Typical	4.0	°C/W
R _{θJA}	Typical	50	°C/W

ON Semiconductor and  are trademarks of Semiconductor Components Industries, LLC (SCILLC). SCILLC reserves the right to make changes without further notice to any products herein. SCILLC makes no warranty, representation or guarantee regarding the suitability of its products for any particular purpose, nor does SCILLC assume any liability arising out of the application or use of any product or circuit, and specifically disclaims any and all liability, including without limitation special, consequential or incidental damages. "Typical" parameters which may be provided in SCILLC data sheets and/or specifications can and do vary in different applications and actual performance may vary over time. All operating parameters, including "Typicals" must be validated for each customer application by customer's technical experts. SCILLC does not convey any license under its patent rights nor the rights of others. SCILLC products are not designed, intended, or authorized for use as components in systems intended for surgical implant into the body, or other applications intended to support or sustain life, or for any other application in which the failure of the SCILLC product could create a situation where personal injury or death may occur. Should Buyer purchase or use SCILLC products for any such unintended or unauthorized application, Buyer shall indemnify and hold SCILLC and its officers, employees, subsidiaries, affiliates, and distributors harmless against all claims, costs, damages, and expenses, and reasonable attorney fees arising out of, directly or indirectly, any claim of personal injury or death associated with such unintended or unauthorized use, even if such claim alleges that SCILLC was negligent regarding the design or manufacture of the part. SCILLC is an Equal Opportunity/Affirmative Action Employer.

PUBLICATION ORDERING INFORMATION

Literature Fulfillment:

Literature Distribution Center for ON Semiconductor
P.O. Box 5163, Denver, Colorado 80217 USA
Phone: 303-675-2175 or 800-344-3860 Toll Free USA/Canada
Fax: 303-675-2176 or 800-344-3867 Toll Free USA/Canada
Email: ONlit@hibbertco.com

N. American Technical Support: 800-282-9855 Toll Free USA/Canada

JAPAN: ON Semiconductor, Japan Customer Focus Center
4-32-1 Nishi-Gotanda, Shinagawa-ku, Tokyo, Japan 141-0031
Phone: 81-3-5740-2700
Email: r14525@onsemi.com

ON Semiconductor Website: <http://onsemi.com>

For additional information, please contact your local Sales Representative.