

## 阅读申明

- 1.本站收集的数据手册和产品资料都来自互联网，版权归原作者所有。如读者和版权方有任何异议请及时告之，我们将妥善解决。
- 2.本站提供的中文数据手册是英文数据手册的中文翻译，其目的是协助用户阅读，该译文无法自动跟随原稿更新，同时也可能存在翻译上的不当。建议读者以英文原稿为参考以便获得更精准的信息。
- 3.本站提供的产品资料，来自厂商的技术支持或者使用者的心得体会等，其内容可能存在描述上的差异，建议读者做出适当判断。
- 4.如需与我们联系，请发邮件到marketing@iczoom.com，主题请标有“数据手册”字样。

## Read Statement

1. The datasheets and other product information on the site are all from network reference or other public materials, and the copyright belongs to the original author and original published source. If readers and copyright owners have any objections, please contact us and we will deal with it in a timely manner.
2. The Chinese datasheets provided on the website is a Chinese translation of the English datasheets. Its purpose is for reader's learning exchange only and do not involve commercial purposes. The translation cannot be automatically updated with the original manuscript, and there may also be improper translations. Readers are advised to use the English manuscript as a reference for more accurate information.
3. All product information provided on the website refer to solutions from manufacturers' technical support or users the contents may have differences in description, and readers are advised to take the original article as the standard.
4. If you have any questions, please contact us at marketing@iczoom.com and mark the subject with "Datasheets" .



# VND05B VND05B (011Y) / VND05B (012Y)

## DOUBLE CHANNEL HIGH SIDE SMART POWER SOLID STATE RELAY

TYPE	V <sub>DSS</sub>	R <sub>DS(on)</sub>	I <sub>n</sub> (*)	V <sub>CC</sub>
VND05B	40V	200mΩ	1.6A	26 V
VND05B (011Y)				
VND05B (012Y)				

- OUTPUT CURRENT (CONTINUOUS): 9A AT T<sub>c</sub>=85°C PER CHANNEL
- 5V LOGIC LEVEL COMPATIBLE INPUT
- THERMAL SHUT-DOWN
- UNDERVOLTAGE PROTECTION
- OPEN DRAIN DIAGNOSTIC OUTPUT
- INDUCTIVE LOAD FAST DEMAGNETIZATION
- VERY LOW STAND-BY POWER DISSIPATION

### DESCRIPTION

The VND05B, VND05B (011Y), VND05B (012Y) is a monolithic device designed in STMicroelectronics VIPower technology, intended for driving resistive or inductive loads with one side connected to ground. This device has two channels, and a common diagnostic. Built-in thermal shutdown protects the chip from overtemperature and short circuit. The status output provides an indication of open load in on state, open load in off state, overtemperature conditions and stuck-on to V<sub>CC</sub>.

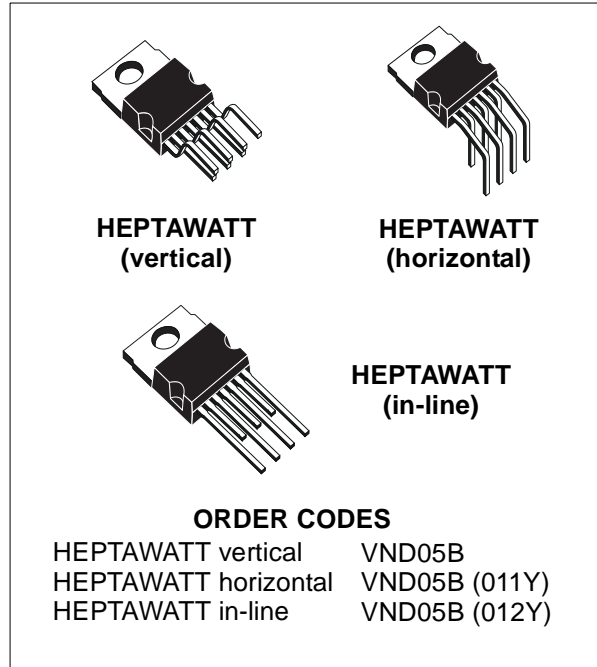

### BLOCK DIAGRAM

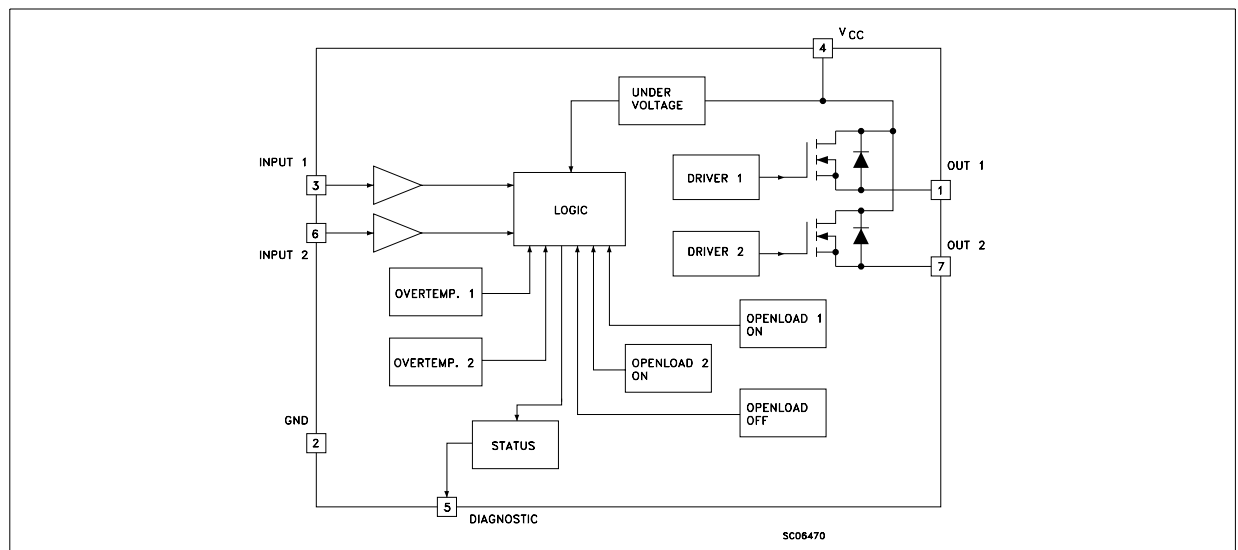

(\*) I<sub>n</sub>= Nominal current according to ISO definition for high side automotive switch (see note 1)

**ABSOLUTE MAXIMUM RATING**

Symbol	Parameter	Value	Unit
$V_{(BR)DSS}$	Drain-Source breakdown voltage	40	V
$I_{OUT}$	Output current (continuous) at $T_c=85^\circ\text{C}$	9	A
$I_{OUT(RMS)}$	RMS Output current at $T_c=85^\circ\text{C}$ and $f > 1\text{Hz}$	9	A
$I_R$	Reverse output current at $T_c=85^\circ\text{C}$	-9	A
$I_{IN}$	Input current	+/- 10	mA
$-V_{CC}$	Reverse supply voltage	-4	V
$I_{STAT}$	Status current	+/- 10	mA
$V_{ESD}$	Electrostatic discharge ( $R=1.5\text{k}\Omega$ , $C=100\text{pF}$ )	2000	V
$P_{TOT}$	Power dissipation at $T_c=25^\circ\text{C}$	59	W
$T_j$	Junction operating temperature	-40 to 150	$^\circ\text{C}$
$T_{STG}$	Storage temperature	-55 to 150	$^\circ\text{C}$

**CONNECTION DIAGRAM TOP VIEW**

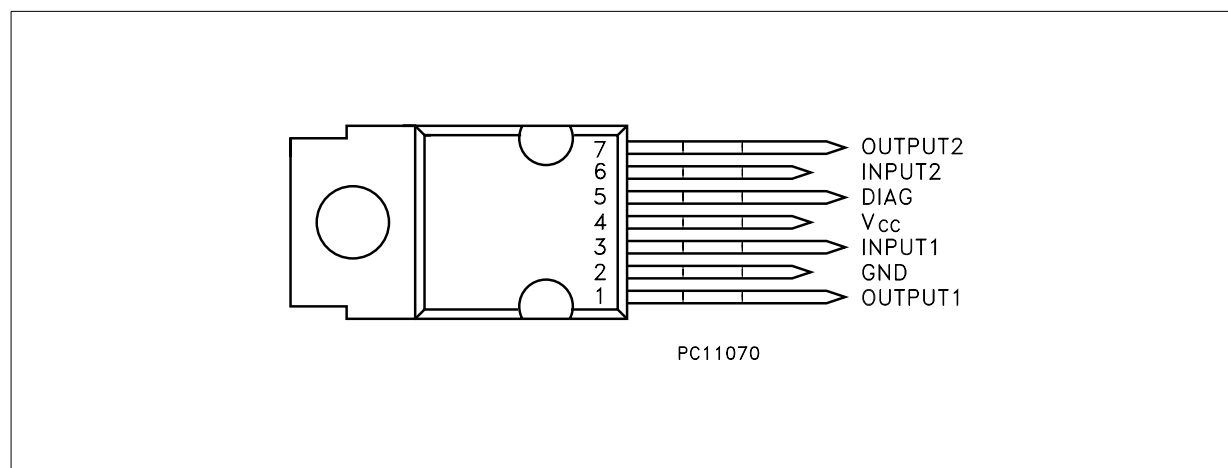

**CURRENT AND VOLTAGE CONVENTIONS**

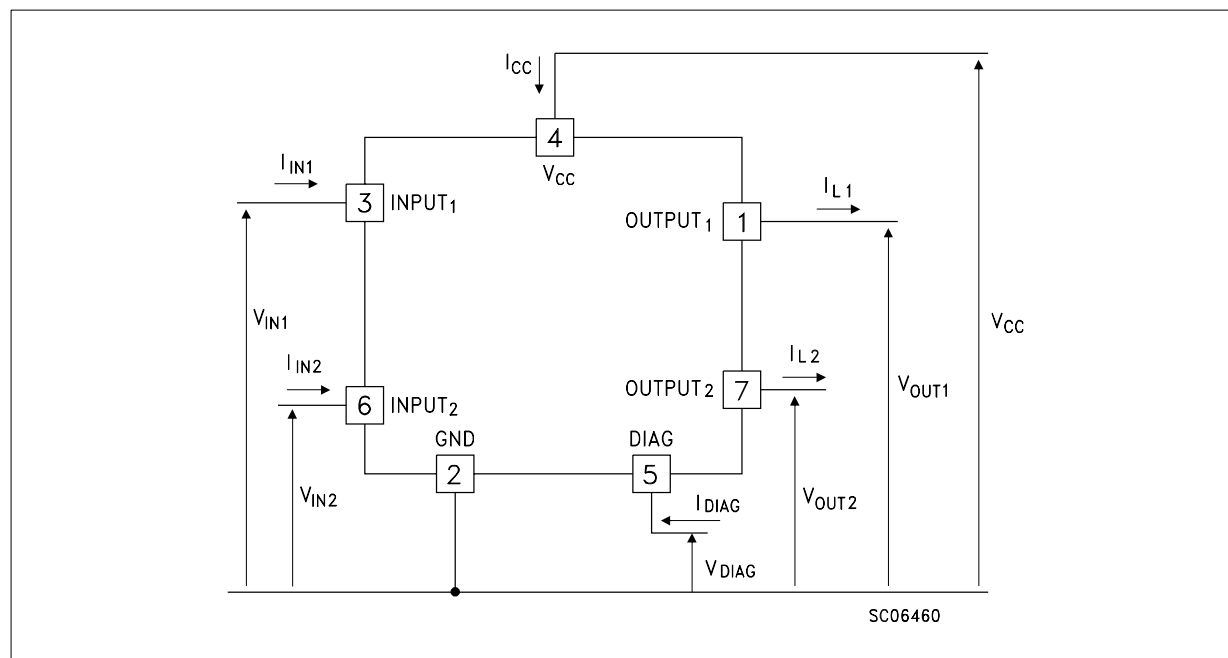

**THERMAL DATA**

Symbol	Parameter	Value	Unit
R <sub>thj-case</sub>	Thermal resistance junction-case (MAX)	2.1	°C/W
R <sub>thj-amb</sub>	Thermal resistance junction-ambient (MAX)	60	°C/W

**ELECTRICAL CHARACTERISTICS** (8V < V<sub>CC</sub> < 16V; -40°C ≤ T<sub>j</sub> ≤ 125°C; unless otherwise specified)**POWER**

Symbol	Parameter	Test Conditions	Min	Typ	Max	Unit
V <sub>CC</sub>	Supply voltage		6	13	26	V
I <sub>n</sub> (*)	Nominal current	T <sub>c</sub> =85°C; V <sub>DS(on)</sub> ≤ 0.5V; V <sub>CC</sub> =13V	1.6		2.6	A
R <sub>ON</sub>	On state resistance	I <sub>OUT</sub> =I <sub>n</sub> ; V <sub>CC</sub> =13V; T <sub>j</sub> =25°C	0.13		0.2	Ω
I <sub>S</sub>	Supply current	Off state; T <sub>j</sub> =25°C; V <sub>CC</sub> =13V		35	100	μA
V <sub>DS(MAX)</sub>	Maximum voltage Drop	I <sub>OUT</sub> =7.5A; T <sub>j</sub> =85°C; V <sub>CC</sub> =13V	1.44		2.3	V
R <sub>i</sub>	Output to GND internal impedance	T <sub>j</sub> =25°C	5	10	20	KΩ

**SWITCHING**

Symbol	Parameter	Test Conditions	Min	Typ	Max	Unit
t <sub>d(on)</sub> (^)	Turn-on delay time of output current	R <sub>OUT</sub> =5.4Ω	5	25	200	μs
t <sub>r</sub> (^)	Rise time of output current	R <sub>OUT</sub> =5.4Ω	10	50	180	μs
t <sub>d(off)</sub> (^)	Turn-off delay time of output current	R <sub>OUT</sub> =5.4Ω	10	75	250	μs
t <sub>f</sub> (^)	Fall time of output current	R <sub>OUT</sub> =5.4Ω	10	35	180	μs
(di/dt) <sub>on</sub>	Turn-on current slope	R <sub>OUT</sub> =5.4Ω	0.003		0.1	A/μs
(di/dt) <sub>off</sub>	Turn-off current slope	R <sub>OUT</sub> =5.4Ω	0.005		0.1	A/μs

**LOGIC INPUT**

Symbol	Parameter	Test Conditions	Min	Typ	Max	Unit
V <sub>IL</sub>	Input low level voltage				1.5	V
V <sub>IH</sub>	Input high level voltage		3.5		(•)	V
V <sub>I(hyst)</sub>	Input hysteresis voltage		0.2	0.9	1.5	V
I <sub>IN</sub>	Input current	V <sub>IN</sub> =5V; T <sub>j</sub> =25°C		30	100	μA
V <sub>ICL</sub>	Input clamp voltage	I <sub>IN</sub> =10mA I <sub>IN</sub> =-10mA	5	6 -0.7	7	V

**ELECTRICAL CHARACTERISTICS** (continued)  
**PROTECTIONS AND DIAGNOSTICS**

Symbol	Parameter	Test Conditions	Min	Typ	Max	Unit
$V_{STAT}$	Low output voltage status	$I_{STAT}=1.6mA$			0.4	V
$V_{USD}$	Undervoltage shut-down		3.5	4.5	6	V
$V_{SCL}$	Status clamp voltage	$I_{STAT}= 10mA$	5	6	7	V
		$I_{STAT}= -10mA$		-0.7		V
$T_{TSD}$	Thermal shut-down temperature		140	160	180	°C
$T_{TSD(hyst)}$	Thermal shutdown hysteresis temperature				50	°C
$T_R$	Reset temperature		125			°C
$V_{OL}$	Open voltage level	Off state (note 2)	2.5	4	5	V
$I_{OL}$	Open load current level	On state	5		180	mA
$t_{povi}$	Overtemperature Status delay	(note 3)		5	10	μs
$t_{pol}$	Open Load Status delay	(note 3)	50	500	2500	μs

(\*)  $I_n$ =Nominal current according to ISO definition for high side automotive switch (see note 1)

(^) See switching time waveform

(•) The  $V_{IH}$  is internally clamped at 6V about. It is possible to connect this pin to an higher voltage via an external resistor calculated to not exceed 10 mA at the input pin.

Note 1: The Nominal Current is the current at  $T_c=85°C$  for battery voltage of 13V which produces a voltage drop of 0.5V

Note 2:  $I_{OL(off)} = (V_{CC}-V_{OL})/R_{OL}$

Note 3:  $t_{povi}$   $t_{pol}$ : ISO definition

Note 2 Relevant Figure

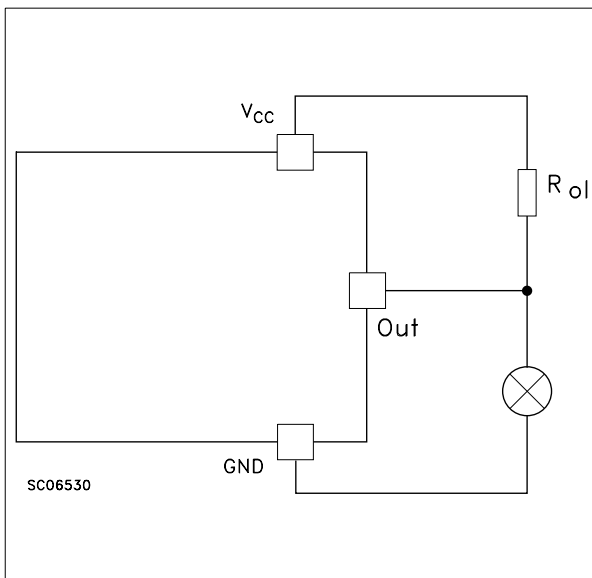

Note 3 Relevant Figure

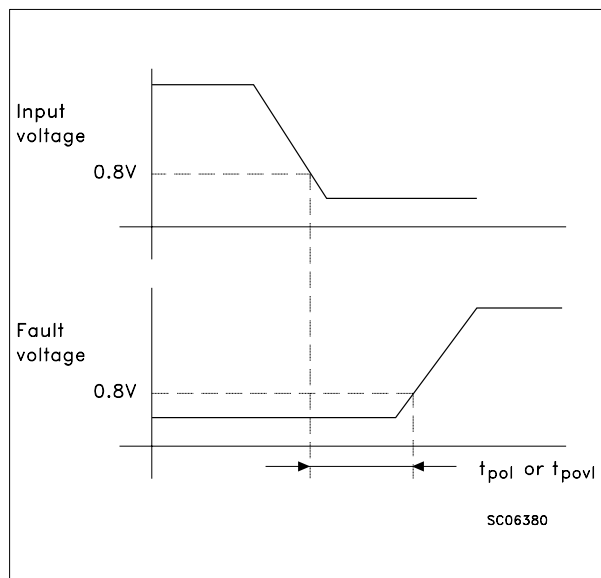

## Switching Time Waveforms

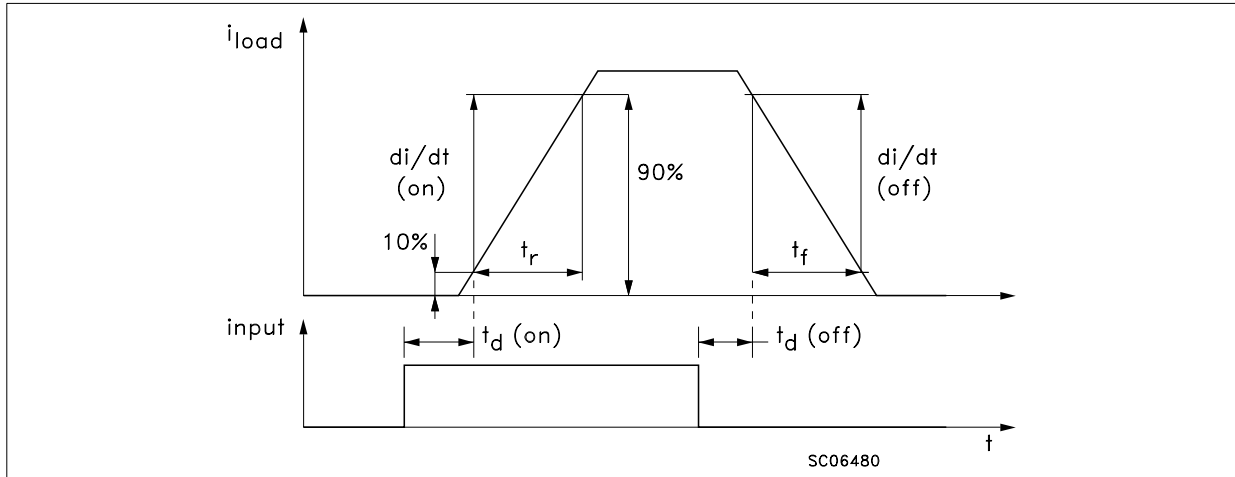

### FUNCTIONAL DESCRIPTION

The device has a common diagnostic output for both channels which indicates open load in on-state, open load in off-state, overtemperature conditions and stuck-on to  $V_{CC}$ .

From the falling edge of the input signal, the status output, initially low to signal a fault condition (overtemperature or open load on-state), will go back to a high state with a different delay in case of overtemperature ( $t_{povl}$ ) and in case of open load ( $t_{pol}$ ) respectively. This feature allows to discriminate the nature of the detected fault. To protect the device against short-circuit and overcurrent condition, the thermal protection turns the integrated PowerMOS off at a minimum junction temperature of 140°C. When this temperature returns to 125°C the switch is automatically turned in again. In short-circuit the protection reacts with virtually no delay, the sensor (one for each channel) being located inside each of the two PowerMOS areas. This positioning allows the device to operate with one channel in automatic thermal cycling and the other one on a normal load. An internal function of the devices ensures the fast demagnetization of inductive loads with a typical voltage ( $V_{demag}$ ) of -18V. This function allows to greatly reduce the power dissipation according to the formula:

$$P_{dem} = 0.5 \cdot L_{load} \cdot (I_{load})^2 \cdot [(V_{CC} + V_{demag}) / V_{demag}] \cdot f$$

where  $f$  = switching frequency and

$V_{demag}$  = demagnetization voltage.

The maximum inductance which causes the chip temperature to reach the shutdown temperature in a specified thermal environment is a function of the load current for a fixed  $V_{CC}$ ,  $V_{demag}$  and  $f$  according to the above formula. In this device if the GND pin is disconnected, with  $V_{CC}$  not exceeding 16V, both channels will switch off.

### PROTECTING THE DEVICE AGAINST REVERSE BATTERY

The simplest way to protect the device against a continuous reverse battery voltage (-26V) is to insert a Schottky diode between pin 2 (GND) and ground, as shown in the typical application circuit (fig. 2).

The consequences of the voltage drop across this diode are as follows:

- If the input is pulled to power GND, a negative voltage of  $-V_f$  is seen by the device. ( $V_{il}$ ,  $V_{ih}$  thresholds and  $V_{STAT}$  are increased by  $V_f$  with respect to power GND).
- The undervoltage shutdown level is increased by  $V_f$ .

If there is no need for the control unit to handle external analog signals referred to the power GND, the best approach is to connect the reference potential of the control unit to the device ground (see application circuit in fig. 3), which becomes the common signal GND for the whole control board avoiding shift on  $V_{il}$ ,  $V_{ih}$  and  $V_{STAT}$ . This solution allows the use of a standard diode.

**THRUTH TABLE**

		INPUT 1	INPUT 2	OUTPUT 1	OUTPUT 2	DIAGNOSTIC
Normal operation		L	L	L	L	H
		H	H	H	H	H
		L	H	L	H	H
		H	L	H	L	H
Undervoltage		X	X	L	L	H
Thermal shutdown	Channel 1	H	X	L	X	L
	Channel 2	X	H	X	L	L
Openload	Channel 1	H	X	H	X	L
		L	L	L	L	L
	Channel 2	X	H	X	H	L
		L	L	L	L	L
Output shorted to V <sub>CC</sub>	Channel 1	H	X	H	X	L
		L	L	H	L	L
	Channel 2	X	H	X	H	L
		L	L	L	H	L

**Figure 1: Waveforms**

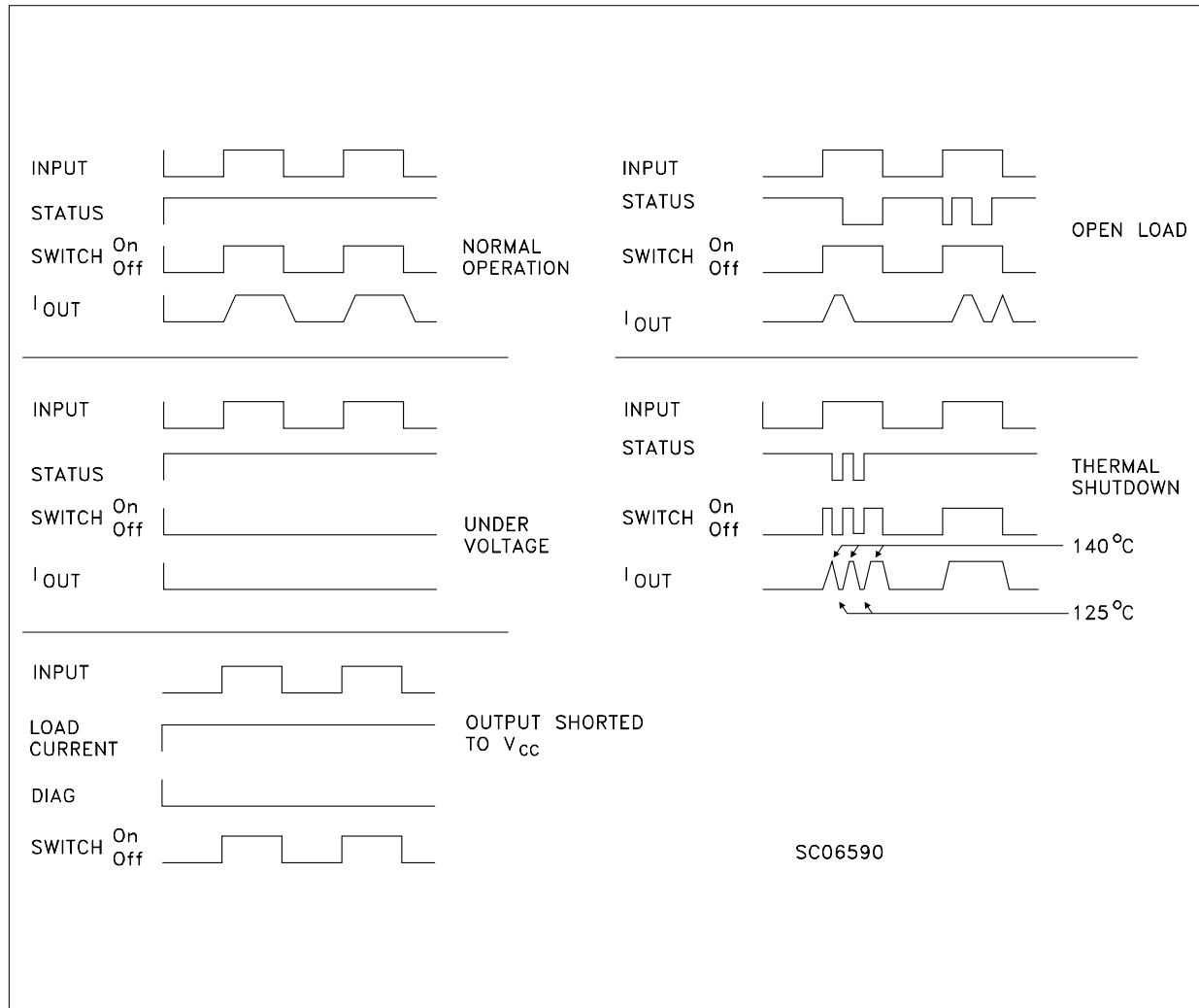

**Figure 2:** Typical application circuit with a Schottky diode for reverse supply protection

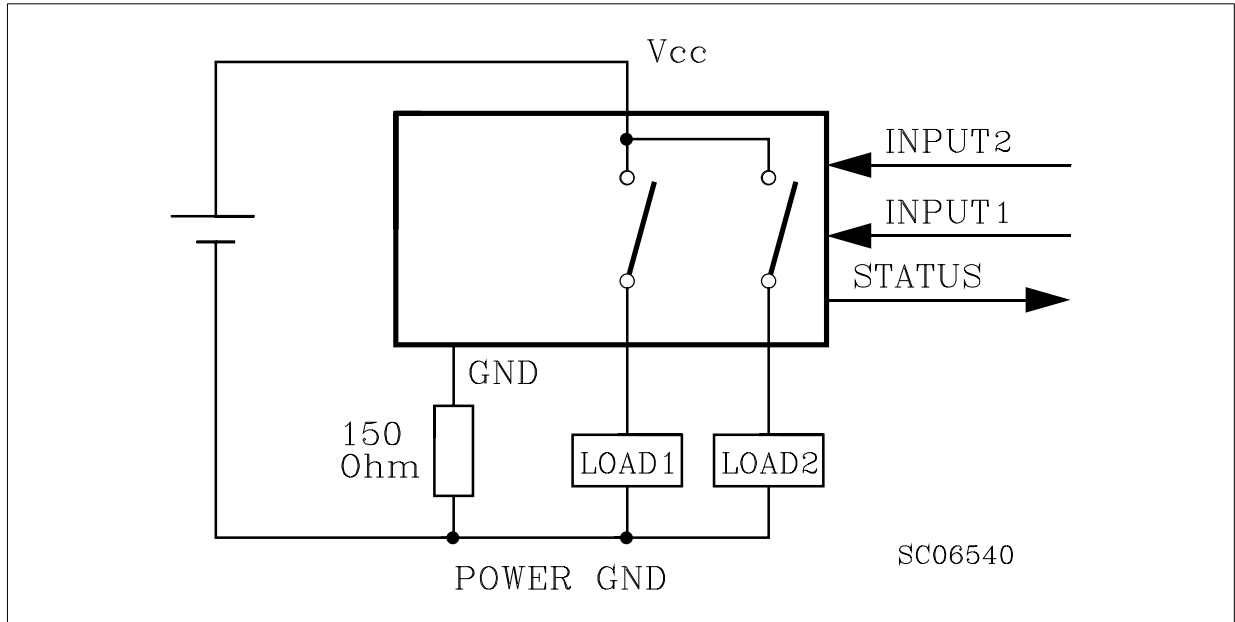

**Figure 3:** Typical application circuit with separate signal ground

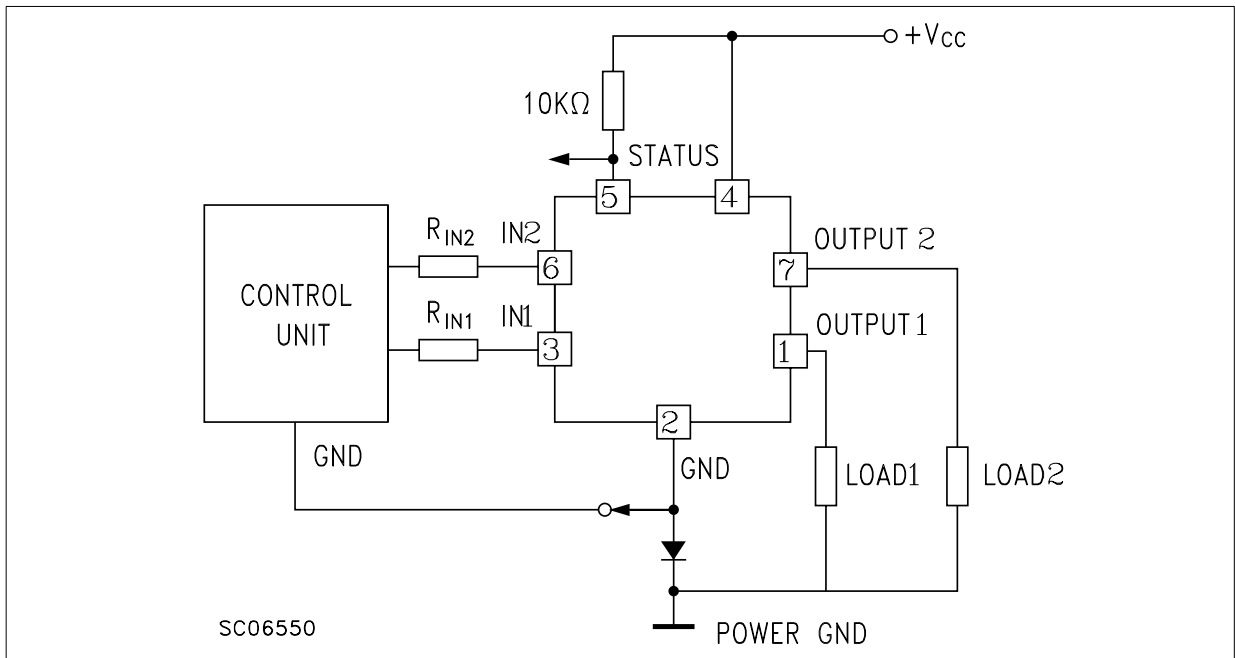



### HEPTAWATT (horizontal) MECHANICAL DATA

DIM.	mm.			inch		
	MIN.	TYP	MAX.	MIN.	TYP.	MAX.
A			4.8			0.189
C			1.37			0.054
D	2.4		2.8	0.094		0.110
D1	1.2		1.35	0.047		0.053
E	0.35		0.55	0.014		0.022
F	0.6		0.8	0.024		0.031
F1			0.9			0.035
G	2.41	2.54	2.67	0.095	0.100	0.105
G1	4.91	5.08	5.21	0.193	0.200	0.205
G2	7.49	7.62	7.8	0.295	0.300	0.307
H2			10.4			0.409
H3	10.05		10.4	0.396		0.409
L		14.2			0.559	
L1		4.4			0.173	
L2		15.8			0.622	
L3		5.1			0.201	
L5	2.6		3	0.102		0.118
L6	15.1		15.8	0.594		0.622
L7	6		6.6	0.236		0.260
L9		4.44			0.175	
Dia	3.65		3.85	0.144		0.152

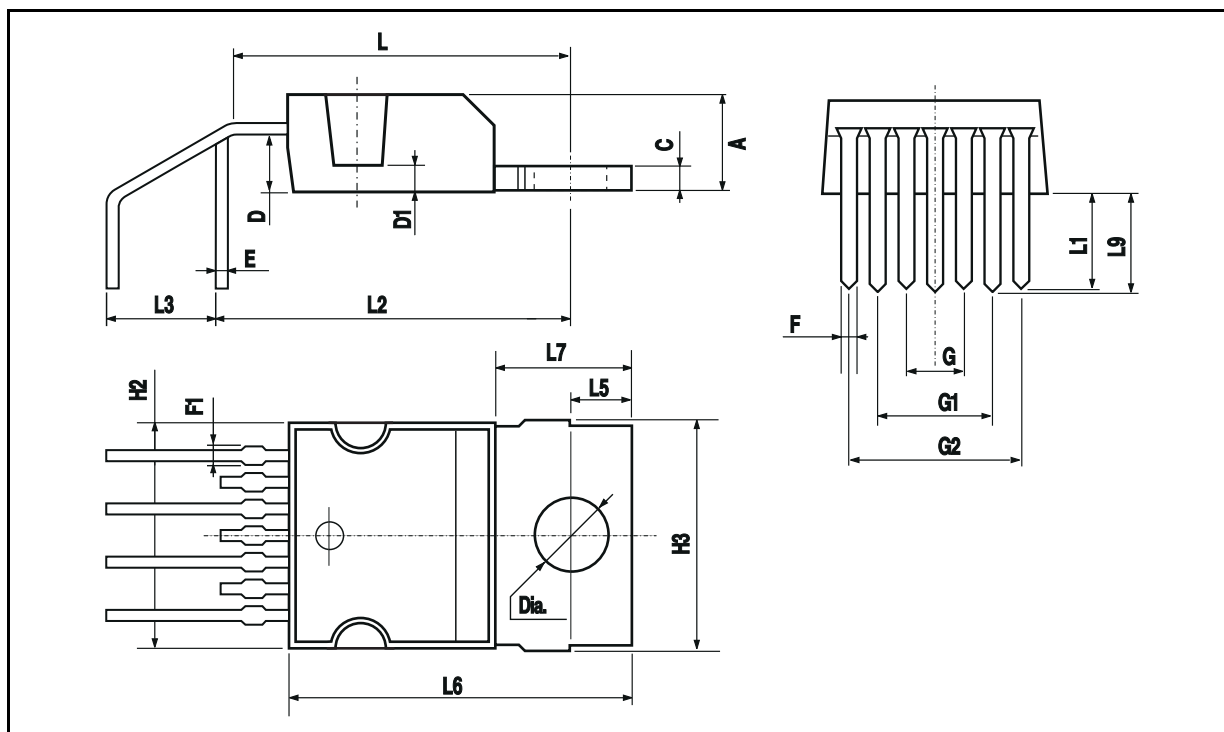

## HEPTAWATT (vertical) MECHANICAL DATA

DIM.	mm.			inch		
	MIN.	TYP	MAX.	MIN.	TYP.	MAX.
A			4.8			0.189
C			1.37			0.054
D	2.4		2.8	0.094		0.110
D1	1.2		1.35	0.047		0.053
E	0.35		0.55	0.014		0.022
F	0.6		0.8	0.024		0.031
F1			0.9			0.035
G	2.41	2.54	2.67	0.095	0.100	0.105
G1	4.91	5.08	5.21	0.193	0.200	0.205
G2	7.49	7.62	7.8	0.295	0.300	0.307
H2			10.4			0.409
H3	10.05		10.4	0.396		0.409
L		16.97			0.668	
L1		14.92			0.587	
L2		21.54			0.848	
L3		22.62			0.891	
L5	2.6		3	0.102		0.118
L6	15.1		15.8	0.594		0.622
L7	6		6.6	0.236		0.260
M		2.8			0.110	
M1		5.08			0.200	

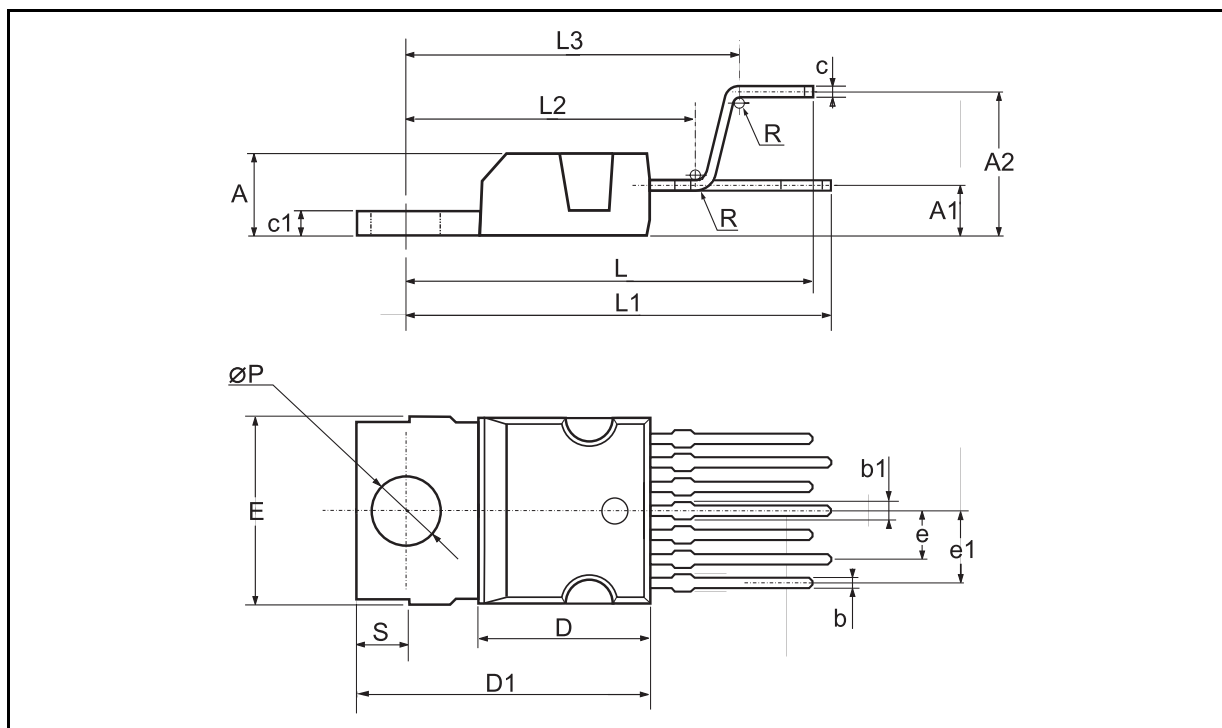

## HEPTAWATT (in-line) MECHANICAL DATA

DIM.	mm.			inch		
	MIN.	TYP	MAX.	MIN.	TYP.	MAX.
A			4.8			0.189
C			1.37			0.054
D	2.4		2.8	0.094		0.110
D1	1.2		1.35	0.047		0.053
E	0.35		0.55	0.014		0.022
F	0.6		0.8	0.024		0.031
F1			0.9			0.035
G	2.41	2.54	2.67	0.095	0.100	0.105
G1	4.91	5.08	5.21	0.193	0.200	0.205
G2	7.49	7.62	7.8	0.295	0.300	0.307
H2			10.4			0.409
H3	10.05		10.4	0.396		0.409
L2	22.4		22.9	0.882		0.902
L3	25.4		26	1.000		1.024
L5	2.6		3	0.102		0.118
L6	15.1		15.8	0.594		0.622
L7	6		6.6	0.236		0.260
Dia.	3.65		3.85	0.144		0.152

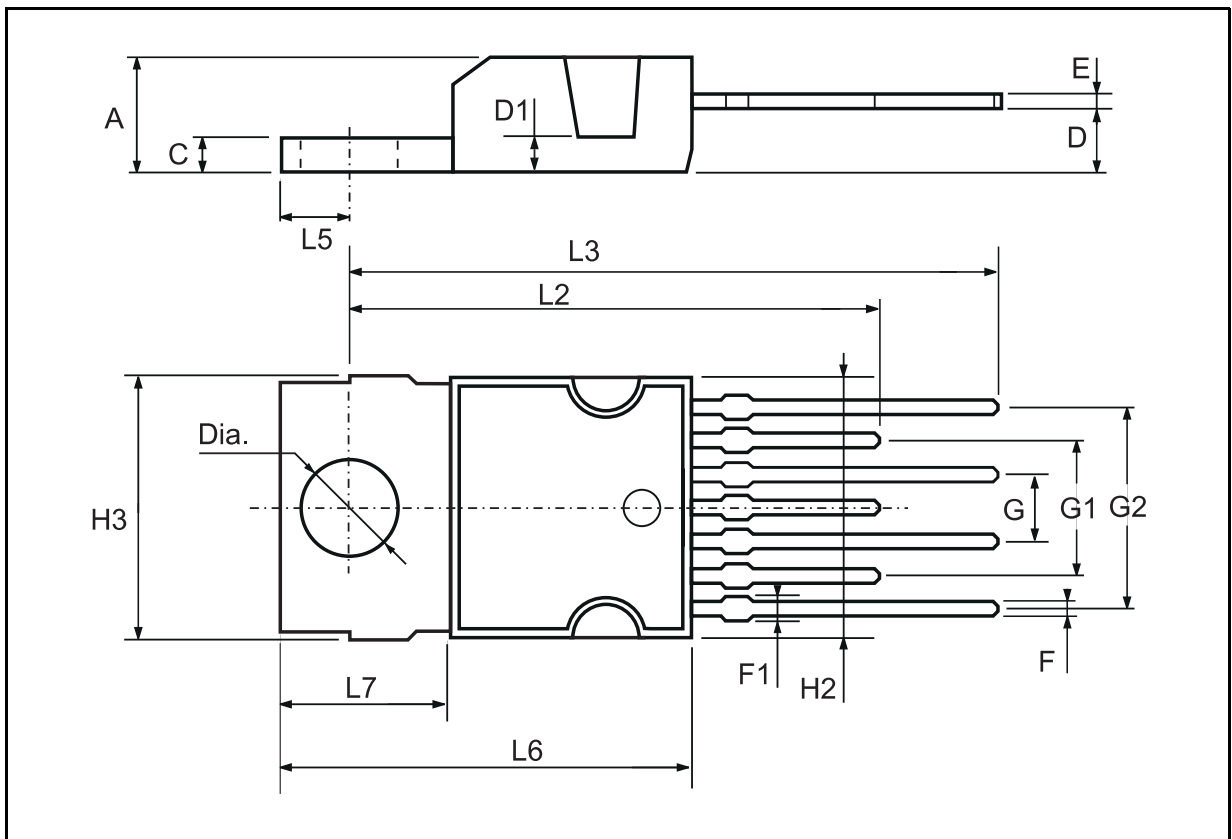

Information furnished is believed to be accurate and reliable. However, STMicroelectronics assumes no responsibility for the consequences of use of such information nor for any infringement of patents or other rights of third parties which may result from its use. No license is granted by implication or otherwise under any patent or patent rights of STMicroelectronics. Specifications mentioned in this publication are subject to change without notice. This publication supersedes and replaces all information previously supplied. STMicroelectronics products are not authorized for use as critical components in life support devices or systems without express written approval of STMicroelectronics.

The ST logo is a trademark of STMicroelectronics

© 1999 STMicroelectronics - Printed in ITALY- All Rights Reserved.

STMicroelectronics GROUP OF COMPANIES

Australia - Brazil - Canada - China - France - Germany - Italy - Japan - Korea - Malaysia - Malta - Mexico - Morocco -  
The Netherlands - Singapore - Spain - Sweden - Switzerland - Taiwan - Thailand - United Kingdom - U.S.A.

<http://www.st.com>