

阅读申明

- 1.本站收集的数据手册和产品资料都来自互联网，版权归原作者所有。如读者和版权方有任何异议请及时告之，我们将妥善解决。
- 2.本站提供的中文数据手册是英文数据手册的中文翻译，其目的是协助用户阅读，该译文无法自动跟随原稿更新，同时也可能存在翻译上的不当。建议读者以英文原稿为参考以便获得更精准的信息。
- 3.本站提供的产品资料，来自厂商的技术支持或者使用者的心得体会等，其内容可能存在描述上的差异，建议读者做出适当判断。
- 4.如需与我们联系，请发邮件到marketing@iczoom.com，主题请标有“数据手册”字样。

Read Statement

1. The datasheets and other product information on the site are all from network reference or other public materials, and the copyright belongs to the original author and original published source. If readers and copyright owners have any objections, please contact us and we will deal with it in a timely manner.
2. The Chinese datasheets provided on the website is a Chinese translation of the English datasheets. Its purpose is for reader's learning exchange only and do not involve commercial purposes. The translation cannot be automatically updated with the original manuscript, and there may also be improper translations. Readers are advised to use the English manuscript as a reference for more accurate information.
3. All product information provided on the website refer to solutions from manufacturers' technical support or users the contents may have differences in description, and readers are advised to take the original article as the standard.
4. If you have any questions, please contact us at marketing@iczoom.com and mark the subject with "Datasheets" .

NCP81022

Dual Output 4 Phase Plus 1 Phase Digital Controller with SVI2 Interface for Desktop and Notebook CPU Applications

The NCP81022 dual output four plus one phase buck solution is optimized for AMD® SVI2 CPUs. The controller combines true differential voltage sensing, differential inductor DCR current sensing, input voltage feed-forward, and adaptive voltage positioning to provide accurately regulated power for both desktop and notebook applications.

The control system is based on Dual-Edge pulse-width modulation (PWM) combined with DCR current sensing providing an ultra fast initial response to dynamic load events and reduced system cost. The NCP81022 provides the mechanism to shed to single phase during light load operation and can auto frequency scale in light load conditions while maintaining excellent transient performance.

Dual high performance operational error amplifiers are provided to simplify compensation of the system. Patented Dynamic Reference Injection further simplifies loop compensation by eliminating the need to compromise between closed-loop transient response and Dynamic VID performance. Patented Total Current Summing provides highly accurate current monitoring for droop and digital current monitoring.

Features

- Meets AMD'S SVI2 Specifications
- Four phase CPU Voltage Regulator
- One phase North Bridge Voltage Regulator
- Current Mode Dual Edge Modulation for Fast Initial Response to Transient Loading
- Dual High Performance Operational Error Amplifier
- One Digital Soft Start Ramp for Both Rails
- Dynamic Reference Injection
- Accurate Total Summing Current Amplifier
- DAC with Droop Feed-forward Injection
- Dual High Impedance Differential Voltage and Total Current Sense Amplifiers
- Phase-to-Phase Dynamic Current Balancing
- "Lossless" DCR Current Sensing for Current Balancing
- Summed Compensated Inductor Current Sensing for Droop
- True Differential Current Balancing Sense Amplifiers for Each Phase
- Adaptive Voltage Positioning (AVP)
- Switching Frequency Range of 240 kHz – 1.0 MHz
- Startup into Pre-Charged Loads while avoiding False OVP
- Power Saving Phase Shedding
- Vin Feed Forward Ramp Slope
- Pin Programming for Internal SVI2 Parameters
- Over Voltage Protection (OVP) and Under Voltage Protection (UVP)
- Over Current Protection (OCP)
- Dual Power Good Output with Internal Delays
- These Devices are Pb-Free and Halogen Free

Applications

- Desktop and Notebook Processors
- Gaming



ON Semiconductor®

www.onsemi.com

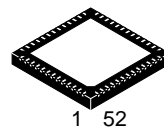

QFN52
CASE 485BE

MARKING DIAGRAM

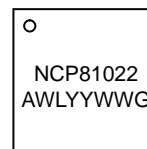

A = Assembly Location
WL = Wafer Lot
YY = Year
WW = Work Week
G = Pb-Free Package

ORDERING INFORMATION

See detailed ordering and shipping information on page 40 of this data sheet.

NCP81022

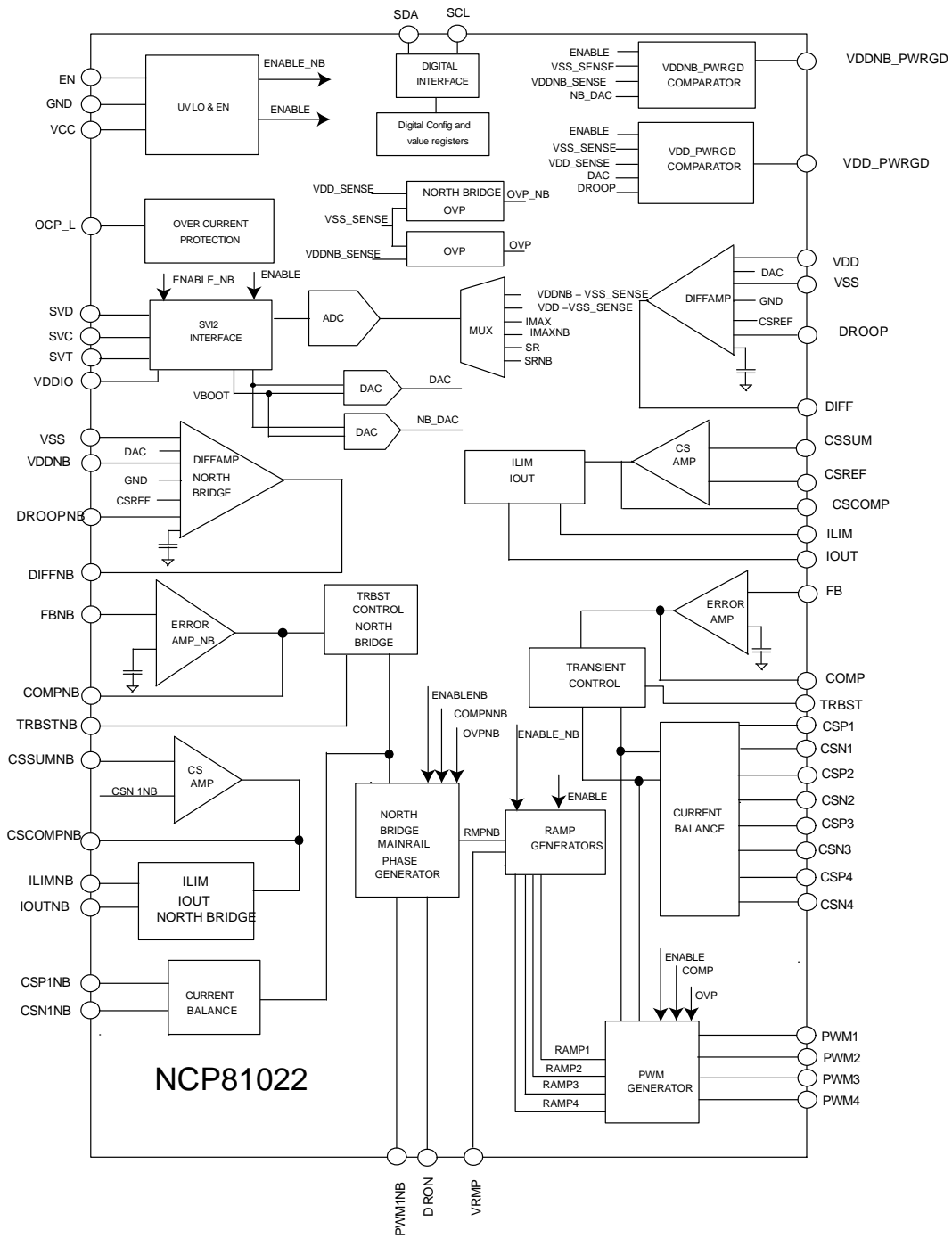

Figure 1. Block Diagram

NCP81022

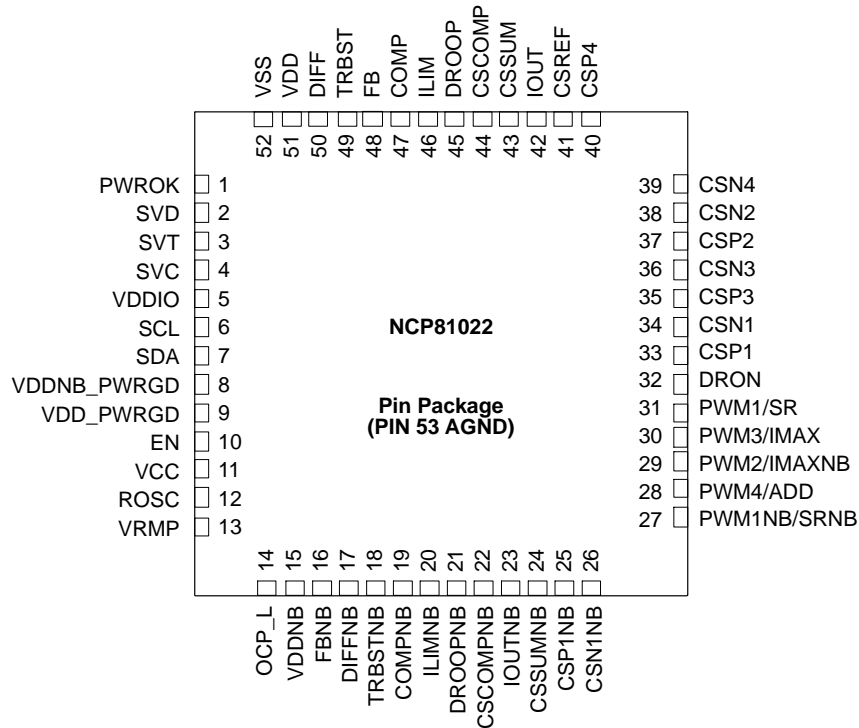

Figure 2. NCP81022 Pinout

QFN52 PIN LIST DESCRIPTION

Pin No.	Symbol	Description
1	PWROK	Active high system wide power ok signal
2	SVD	Serial VID data line
3	SVT	Serial VID telemetry line
4	SVC	Serial VID clock line
5	VDDIO	VDDIO is an interface power rail that serves as a reference for SVI2 interface
6	SCL	serial clock line, Open drain, requires pullup resistor
7	SDA	Bi directional serial data line. Open drain, requires pullup resistor.
8	VDDNB_PWRGD	Open drain output. High output on this pin indicates that the North Bridge Rail output is regulating.
9	VDD_PWRGD	Open drain output. High output on this pin indicates that the Main Rail output is regulating.
10	EN	Logic input. Logic high enables Main and North Bridge Rail output and logic low disables main rail output.
11	VCC	Power for the internal control circuits. A decoupling capacitor is connected from this pin to ground.
12	ROSC	A resistor to ground on this pin will set the oscillator frequency
13	VRMP	Feed-forward input of V_{in} for the ramp slope compensation. The current fed into this pin is used to control of the ramp of PWM slope
14	OCP_L	Open drain output. Signals an over current event has occurred
15	VDDNB	Non-inverting input to the North Bridge Rail differential remote sense amplifier.
16	FBNB	Error amplifier voltage feedback for North Bridge Rail output
17	DIFFNB	Output of the North Bridge Rail differential remote sense amplifier.
18	TRBSTNB	Compensation pin for the load transient boost for North Bridge Rail
19	COMPNB	Output of the error amplifier and the inverting inputs of the PWM comparators for the North Bridge Rail output.

NCP81022

QFN52 PIN LIST DESCRIPTION

Pin No.	Symbol	Description
20	ILIMNB	Over current shutdown threshold setting for North Bridge Rail output. Resistor to CSCOMP to set threshold.
21	DROOPNB	Used to program DACFF function for North Bridge Rail output. It's connected to the resistor divider placed between CSCOMP and CSREFNB summing node.
22	CSCOMP	Output of total current sense amplifier for North Bridge Rail output.
23	IOUTNB	Total output current monitor for North Bridge Rail.
24	CSSUMNB	Inverting input of total current sense amplifier for North Bridge Rail output.
25	CSP1NB	Non-inverting input to current balance sense amplifier for phase 1NB
26	CSN1NB	Inverting input to current balance sense amplifier for phase1NB
27	PWM1NB/SRNB	North Bridge Phase1 PWM output. A resistor from this pin to ground programs SR North Bridge rail
28	PWM4/ADD	Main Rail Phase 4PWM output. A resistor from this pin to ground programs the SMBus address.
29	PWM2/IMAXNB	Main Rail Phase 2PWM output. During start up it is used to program ICC_MAX for the North Bridge Rail with a resistor to ground
30	PWM3/IMAX	Main Rail Phase 3PWM output. During start up it is used to program ICC_MAX for the Main Rail with a resistor to ground
31	PWM1/SR	Main Rail Phase 1PWM output. A resistor to ground on this pin programs SR Main rail.
32	DRON	Bidirectional gate driver enable for external drivers for both Main and North Bridge Rails. It should be left floating if unused.
33	CSP1	Non-inverting input to current balance sense amplifier for Main Rail phase 1
34	CSN1	Non-inverting input to current balance sense amplifier for Main Rail phase 1
35	CSP3	Non-inverting input to current balance sense amplifier for Main Rail phase 3
36	CSN3	Inverting input to current balance sense amplifier for Main Rail phase3
37	CSP2	Non-inverting input to current balance sense amplifier for Main Rail phase 2
38	CSN2	Inverting input to current balance sense amplifier for Main Rail phase2
39	CSN4	Inverting input to current balance sense amplifier for Main Rail phase4
40	CSP4	Non-inverting input to current balance sense amplifier for Main Rail phase 4
41	CSREF	Total output current sense amplifier reference voltage input for Main Rail and inverting input to Main Rail current balance sense amplifier for phase 1 and 2
42	IOUT	Total output current monitor for Main Rail.
43	CSSUM	Inverting input of total current sense amplifier for Main Rail output
44	CSCOMP	Output of total current sense amplifier for Main Rail output
45	DROOP	Used to program DACFF function for Main Rail output. It's connected to the resistor divider placed between CSCOMP and CSREF.
46	ILM	Over current shutdown threshold setting for Main Rail output. Resistor to CSCOMP to set threshold.
47	COMP	Output of the Main Rail error amplifier and the inverting input of the PWM comparator for Main Rail output
48	FB	Error amplifier voltage feedback for Main Rail output
49	TRBST	Compensation pin for the load transient boost for Main Rail
50	DIFF	Output of the Main Rail differential remote sense amplifier.
51	VDD	Non-inverting input to the Main Rail differential remote sense amplifier
52	VSS	Inverting input to the Main Rail differential remote sense amplifier.
53	AGND	

NCP81022

ABSOLUTE MAXIMUM RATINGS

ELECTRICAL INFORMATION

Pin Symbol	V _{MAX}	V _{MIN}	I _{SOURCE}	I _{SINK}
COMP, COMPNB	VCC + 0.3 V	-0.3 V	2 mA	2 mA
CSCOMP, CSCOMPNB	VCC + 0.3 V	-0.3 V	2 mA	2 mA
VSS,	GND + 300 mV	GND - 300 mV	1 mA	1 mA
VDD_PWRGD, VDDNB_PWRGD	VCC + 0.3 V	-0.3 V	N/A	2 mA
VCC	6.5 V	-0.3 V	N/A	N/A
VRMP	+25 V	-0.3 V		
All Other Pins	VCC + 0.3 V	-0.3 V		

*All signals referenced to GND unless noted otherwise.

THERMAL INFORMATION

Description	Symbol	Typ	Unit
Thermal Characteristic – QFN Package (Note 1)	R _{JA}	68	°C/W
Operating Junction Temperature Range (Note 2)	T _J	-10 to 125	°C
Operating Ambient Temperature Range		-10 to 100	°C
Maximum Storage Temperature Range	T _{STG}	-40 to +150	°C
Moisture Sensitivity Level – QFN Package	MSL	1	

*The maximum package power dissipation must be observed.

1. JESD 51-5 (1S2P Direct-Attach Method) with 0 LFM
2. JESD 51-7 (1S2P Direct-Attach Method) with 0 LFM

NCP81022 (4+1) ELECTRICAL CHARACTERISTICS

Unless otherwise stated: -10°C < T_A < 100°C; 4.75 V < VCC < 5.25 V; C_{VCC} = 0.1 μF

Parameter	Test Conditions	MIN	TYP	MAX	Unit
-----------	-----------------	-----	-----	-----	------

ERROR AMPLIFIER

Input Bias Current		-400		400	nA
Open Loop DC Gain	C _L = 20 pF to GND, R _L = 10 kΩ to GND		80		dB
Open Loop Unity Gain Bandwidth	C _L = 20 pF to GND, R _L = 10 kΩ to GND		55		MHz
Slew Rate	ΔV _{in} = 100 mV, G = -10 V/V, ΔV _{out} = 1.5 V - 2.5 V, C _L = 20 pF to GND, DC Load = 10k to GND		20		mV/μs
Maximum Output Voltage	I _{SOURCE} = 2.0 mA	3.5	-	-	V
Minimum Output Voltage	I _{SINK} = 2.0 mA	-	-	1	V

DIFFERENTIAL SUMMING AMPLIFIER

Input Bias Current		-400	-	400	nA
VDD Input Voltage Range		-0.3	-	3.0	V
VSS Input Voltage Range		-0.3	-	0.3	V
-3dB Bandwidth	C _L = 20 pF to GND, R _L = 10 kΩ to GND		12		MHz
Closed Loop DC gain VS to DIFF	VS+ to VS- = 0.5 to 1.3 V		1.0		V/V
Droop Accuracy	CSREF-DROOP = 80 mV DAC = 0.8 V to 1.2 V	-1.5		+1.5	mV

NCP81022

NCP81022 (4+1) ELECTRICAL CHARACTERISTICS

Unless otherwise stated: $-10^{\circ}\text{C} < T_A < 100^{\circ}\text{C}$; $4.75\text{ V} < V_{CC} < 5.25\text{ V}$; $C_{VCC} = 0.1\ \mu\text{F}$

Parameter	Test Conditions	MIN	TYP	MAX	Unit
-----------	-----------------	-----	-----	-----	------

DIFFERENTIAL SUMMING AMPLIFIER

Maximum Output Voltage	$I_{SOURCE} = 2\text{ mA}$	3.0	-	-	V
Minimum Output Voltage	$I_{SINK} = 2\text{ mA}$	-	-	0.5	V

CURRENT SUMMING AMPLIFIER

Offset Voltage (Vos)	1.2 V	-300		300	μV
Input Bias Current	$CSSUM = CSREF = 0.5 - 1.5\text{ V}$	-1		1	μA
Open Loop Gain			80		dB
Current Sense Unity Gain Bandwidth	$C_L = 20\text{ pF to GND}$, $R_L = 10\text{ k}\Omega\text{ to GND}$		10		MHz
Maximum CSCOMP (NB) Output Voltage	$I_{source} = 2\text{ mA}$	3.5	-	-	V
Minimum CSCOMP(NB) Output Voltage	$I_{sink} = 500\mu\text{A}$	-	-	0.15	V

CURRENT BALANCE AMPLIFIER

Input Bias Current	$CSP1-4NB = CSN1-4NB = 1.2\text{ V}$ $CSP = CSN = 1.2\text{ V}$	-200	-	200	nA
Common Mode Input Voltage Range	$CSPx = CSREF$	0	-	2.0	V
Differential Mode Input Voltage Range	$CSNx = 1.2\text{ V}$	-100	-	100	mV
Closed loop Input Offset Voltage Matching	$CSPx = CSNx = 1.2\text{ V}$, Measured from the average	-1.5	-	1.5	mV
Current Sense Amplifier Gain	$0\text{V} < CSPx - CSNx < 0.1\text{ V}$,	5.7	6.0	6.3	V/V
Multiphase Current Sense Gain Matching	$CSN = CSP = 10\text{ mV to }30\text{ mV}$	-3.8		3.8	%
-3dB Bandwidth			8		MHz

BIAS SUPPLY

Supply Voltage Range		4.75		5.25	
VCC Quiescent Current				48	mA
UVLO Threshold	VCC rising			4.5	V
	VCC falling	3.9			V
VCC UVLO Hysteresis			200		mV

VRMP

Supply range		4.5		20	V
UVLO Threshold	VCC rising	4.2			V
	VCC falling			3	V
Hysteresis			800		mV

DAC SLEW RATE

Soft Start Slew Rate			2.5		$\text{mV}/\mu\text{s}$
Slew Rate Slow			5		$\text{mV}/\mu\text{s}$
Slew Rate Fast			20		$\text{mV}/\mu\text{s}$
NORTH BRIDGE Soft Start Slew Rate			2.5		$\text{mV}/\mu\text{s}$
NORTH BRIDGE Slew Rate Slow			2.5		$\text{mV}/\mu\text{s}$
NORTH BRIDGE Slew Rate Fast			10		$\text{mV}/\mu\text{s}$

ENABLE INPUT

Enable High Input Leakage Current	External 1k pull-up to 3.3 V	-		1.0	μA
Upper Threshold	V_{UPPER}	2			V

NCP81022

NCP81022 (4+1) ELECTRICAL CHARACTERISTICS

Unless otherwise stated: $-10^{\circ}\text{C} < T_A < 100^{\circ}\text{C}$; $4.75\text{ V} < V_{CC} < 5.25\text{ V}$; $C_{VCC} = 0.1\ \mu\text{F}$

Parameter	Test Conditions	MIN	TYP	MAX	Unit
-----------	-----------------	-----	-----	-----	------

ENABLE INPUT

Lower Threshold	V_{LOWER}			0.8	V
Enable delay time	Measure time from Enable transitioning HI, VBOOT is not 0 V			15	μs

DRON

Output High Voltage	Sourcing 500 μA	3.0	–	–	V
Output Low Voltage	Sinking 500 μA	–	–	0.1	V
Pull Up Resistances			2.0		$\text{k}\Omega$
Rise/Fall Time	CL (PCB) = 20 pF, $\Delta V_o = 10\%$ to 90%		160		ns
Internal Pull Down Resistance	EN = Low		70		$\text{k}\Omega$

IOUT OUTPUT /IOUTNB

Input Referred Offset Voltage	Ilimit to CSREF	–3		+3	mV
Output current max	Ilim Sink current 80 μA	–	–	800	μA
Current Gain	$(I_{\text{OUTCURRENT}}) / (I_{\text{LIMITCURRENT}})$, $R_{\text{LIM}} = 20\text{k}$, $R_{\text{IOUT}} = 5.0\text{k}$, DAC = 0.8 V, 1.25 V, 1.52 V	9.5	10	10.5	

OSCILLATOR

Switching Frequency Range		240	–	1000	kHz
Switching Frequency Accuracy	200 kHz < Fsw < 1 MHz	–10	–	10	%
4 Phase Operation		360	400	440	kHz

OUTPUT OVER VOLTAGE AND UNDER VOLTAGE PROTECTION (OVP & UVP)

Over Voltage Threshold During Soft–Start	VDD rising	270	325	380	mV
Over Voltage Delay	VDD rising to PWMx low		50		ns
Under Voltage Threshold Below DAC–DROOP	VDD falling	170	325	380	mV
Under–voltage Hysteresis	VDD rising		25		mV
Under–voltage Delay			5		μs

SVI2 DAC

System Voltage Accuracy	$1.2\text{ V} \leq \text{DAC} < 1.55\text{ V}$ $0.8\text{ V} < \text{DAC} < 1.2\text{ V}$ $0.0\text{ V DAC} < 0.800\text{ V}$	–2 –10 –2		2 10 2	LSB mV LSB
Feed–Forward Current	Measure on DROOP, DROOPNB pin	59	66	71	μA
Droop Falling current	Measure on DROOP, DROOPNB pin	23		29	μA
Droop Feed–Forward Pulse On–Time			0.16		μs

OVERCURRENT PROTECTION

ILIM Threshold Current (OCP shutdown after 50 μs delay)	Main Rail, RLIM = 20 $\text{k}\Omega$	8	10	11.0	μA
ILIM Threshold Current (immediate OCP shutdown)	Main Rail, RLIM = 20 $\text{k}\Omega$	13	15	16.5	μA
ILIM Threshold Current (OCP shutdown after 50 μs delay)	Main Rail, (PSI0, PSI1) RLIM = 20 $\text{k}\Omega$		10		μA
ILIM Threshold Current (immediate OCP shutdown)	Main Rail, (PSI0, PSI1) RLIM = 20 $\text{k}\Omega$		15		μA

NCP81022

NCP81022 (4+1) ELECTRICAL CHARACTERISTICS

Unless otherwise stated: $-10^{\circ}\text{C} < T_A < 100^{\circ}\text{C}$; $4.75\text{ V} < \text{VCC} < 5.25\text{ V}$; $C_{\text{VCC}} = 0.1\ \mu\text{F}$

Parameter	Test Conditions	MIN	TYP	MAX	Unit
-----------	-----------------	-----	-----	-----	------

OVERCURRENT PROTECTION

ILIM Threshold Current (OCP shutdown after 50 μs delay)	North Bridge Rail, RLIM = 20 k Ω	8	10	11.0	μA
ILIM Threshold Current (immediate OCP shutdown)	North Bridge Rail, RLIM = 20 k Ω	13	15	16.5	μA
ILIM Threshold Current (OCP shutdown after 50 μs delay)	North Bridge Rail RLIM = 20 k Ω		10		μA
ILIM Threshold Current (immediate OCP shutdown)	North Bridge Rail, RLIM = 20 k Ω		15		μA

MODULATORS (PWM COMPARATORS) FOR MAIN RAIL AND NORTH BRIDGE

Minimum Pulse Width	Fsw = 360 kHz		60		ns
0% Duty Cycle	COMP voltage when the PWM outputs remain LO		1.3	-	V
100% Duty Cycle	COMP voltage when the PWM outputs remain HI VRMP = 12.0 V	-	2.5	-	V
PWM Ramp Duty Cycle Matching	COMP = 2 V, PWM Ton matching		1		%
PWM Phase Angle Error	Between adjacent phases		± 5		Deg
Ramp Feed-forward Voltage range		5		22	V

TRBST#

Output Low Voltage	$I_{\text{sink}} = 500\ \mu\text{A}$		100		mV
--------------------	--------------------------------------	--	-----	--	----

OCP_L#

Output Low Voltage				0.3	V
Output Leakage Current	High Impedance State	-1.0	-	1.0	μA

ADC

Voltage Range		0		2	V
Total Unadjusted Error (TUE)		-1.25		1.25	%
Differential Nonlinearity (DNL)	8-bit, No Missing codes			1	LSB
Power Supply Sensitivity			± 1		%
Conversion Time			30		μs
Round Robin			90		μs

VDD_PWRGD, VDDNB_PWRGD OUTPUT

Output Low Saturation Voltage	$I_{\text{VDD(NB)_PWRGD}} = 4\ \text{mA}$,	-	-	0.3	V
Rise Time	External pull-up of 1 k Ω to 3.3 V, $C_{\text{TOT}} = 45\ \text{pF}$, $\Delta V_o = 10\%$ to 90%	-	100		ns
Fall Time	External pull-up of 1 k Ω to 3.3V, $C_{\text{TOT}} = 45\ \text{pF}$, $\Delta V_o = 90\%$ to 10%		10		ns
Output Voltage at Power-up	VDD_PWRGD, VDDNB_PWRGD pulled up to 5V via 2 k Ω	-	-	1.2	V
Output Leakage Current When High	VDD_PWRGD & VDDNB_PWRGD = 5.0 V	-1.0	-	1.0	μA
VDD_PWRGD Delay (rising)	DAC=TARGET to VDD_PWRGD		5		μs
VDD_PWRGD Delay (falling)	From OCP or OVP	-	5	-	μs

PWM, PWMNB OUTPUTS

Output High Voltage	Sourcing 500 μA	$\text{VCC} - 0.2$	-	-	V
---------------------	----------------------------	--------------------	---	---	---

NCP81022

NCP81022 (4+1) ELECTRICAL CHARACTERISTICS

Unless otherwise stated: $-10^{\circ}\text{C} < T_A < 100^{\circ}\text{C}$; $4.75\text{ V} < V_{CC} < 5.25\text{ V}$; $C_{VCC} = 0.1\ \mu\text{F}$

Parameter	Test Conditions	MIN	TYP	MAX	Unit
-----------	-----------------	-----	-----	-----	------

PWM, PWMNB OUTPUTS

Output Mid Voltage	No Load	1.9	2.0	2.1	V
Output Low Voltage	Sinking 500 μA	–	–	0.7	V
Rise and Fall Time	CL (PCB) = 50 pF, $\Delta V_o = \text{GND to VCC}$	–	10		ns
Tri-State Output Leakage	$G_x = 2.0\text{ V}$, $x = 1-4$, EN = Low	-1.0	–	1.0	μA

2/3/4 PHASE DETECTION FOR MAIN BRIDGE

CSN2, CSN3, CSN4 Pin Threshold Voltage		4.7			V
Phase Detect Timer			2.3		ms

SVC, SVD, SVT, PWROK

VDDIO	Nominal Bus voltage	1.14		1.95	V
VIL	Input Low Voltage			35	%
VDDIO Current	VDDIO = 1.95			100	μA
VIH	Input High Voltage	70			%
VHYS	Hysteresis Voltage	10			%
VOH	Output High Voltage	VDDIO – 0.2		VDDIO	V
VOL	Output Low Voltage	0		0.2	V
Leakage Current		-100		100	μA
Pad Capacitance				4.0	pF
clock to data delay (Tco)		4		8.3	ns
Setup time (Tsu)		5		10	ns
Hold time (Thold)		5		10	ns

SMBus INTERFACE, SDA, SCL

Logic High Input Voltage	$V_{IH}(\text{SDA, SCL})$	2.1			V
Logic Low Input Voltage	$V_{IL}(\text{SDA, SCL})$			0.8	V
Hysteresis			500		mV
SDA Output low voltage, V_{OL}	$I_{SDA} = -6\text{ mA}$			0.4	V
Input Current		-1		1	μA
Input Capacitance			5.0		pF
Clock Frequency				400	kHz
SCL Falling Edge to SDA Valid Time				1.0	μs

NCP81022

Table 1. SVI2 VID CODES

VID7	VID6	VID5	VID4	VID3	VID2	VID1	VID0	Voltage (V)	HEX
0	0	0	0	0	0	0	0	1.55000	00
0	0	0	0	0	0	0	1	1.54375	01
0	0	0	0	0	0	1	0	1.53750	02
0	0	0	0	0	0	1	1	1.53125	03
0	0	0	0	0	1	0	0	1.52500	04
0	0	0	0	0	1	0	1	1.51875	05
0	0	0	0	0	1	1	0	1.51250	06
0	0	0	0	0	1	1	1	1.50625	07
0	0	0	0	1	0	0	0	1.50000	08
0	0	0	0	1	0	0	1	1.49375	09
0	0	0	0	1	0	1	0	1.48750	0A
0	0	0	0	1	0	1	1	1.48125	0B
0	0	0	0	1	1	0	0	1.47500	0C
0	0	0	0	1	1	0	1	1.46875	0D
0	0	0	0	1	1	1	0	1.46250	0E
0	0	0	0	1	1	1	1	1.45625	0F
0	0	0	1	0	0	0	0	1.45000	10
0	0	0	1	0	0	0	1	1.44375	11
0	0	0	1	0	0	1	0	1.43750	12
0	0	0	1	0	0	1	1	1.43125	13
0	0	0	1	0	1	0	0	1.42500	14
0	0	0	1	0	1	0	1	1.41875	15
0	0	0	1	0	1	1	0	1.41250	16
0	0	0	1	0	1	1	1	1.40625	17
0	0	0	1	1	0	0	0	1.40000	18
0	0	0	1	1	0	0	1	1.39375	19
0	0	0	1	1	0	1	0	1.38750	1A
0	0	0	1	1	0	1	1	1.38125	1B
0	0	0	1	1	1	0	0	1.37500	1C
0	0	0	1	1	1	0	1	1.36875	1D
0	0	0	1	1	1	1	0	1.36250	1E
0	0	0	1	1	1	1	1	1.35625	1F
0	0	1	0	0	0	0	0	1.35000	20
0	0	1	0	0	0	0	1	1.34375	21
0	0	1	0	0	0	1	0	1.33750	22
0	0	1	0	0	0	1	1	1.33125	23
0	0	1	0	0	1	0	0	1.32500	24
0	0	1	0	0	1	0	1	1.31875	25
0	0	1	0	0	1	1	0	1.31250	26
0	0	1	0	0	1	1	1	1.30625	27
0	0	1	0	1	0	0	0	1.30000	28
0	0	1	0	1	0	0	1	1.29375	29

NCP81022

Table 1. SVI2 VID CODES

VID7	VID6	VID5	VID4	VID3	VID2	VID1	VID0	Voltage (V)	HEX
0	0	1	0	1	0	1	0	1.28750	2A
0	0	1	0	1	0	1	1	1.28125	2B
0	0	1	0	1	1	0	0	1.27500	2C
0	0	1	0	1	1	0	1	1.26875	2D
0	0	1	0	1	1	1	0	1.26250	2E
0	0	1	0	1	1	1	1	1.25625	2F
0	0	1	1	0	0	0	0	1.25000	30
0	0	1	1	0	0	0	1	1.24375	31
0	0	1	1	0	0	1	0	1.23750	32
0	0	1	1	0	0	1	1	1.23125	33
0	0	1	1	0	1	0	0	1.22500	34
0	0	1	1	0	1	0	1	1.21875	35
0	0	1	1	0	1	1	0	1.21250	36
0	0	1	1	0	1	1	1	1.20625	37
0	0	1	1	1	0	0	0	1.20000	38
0	0	1	1	1	0	0	1	1.19375	39
0	0	1	1	1	0	1	0	1.18750	3A
0	0	1	1	1	0	1	1	1.18125	3B
0	0	1	1	1	1	0	0	1.17500	3C
0	0	1	1	1	1	0	1	1.16875	3D
0	0	1	1	1	1	1	0	1.16250	3E
0	0	1	1	1	1	1	1	1.15625	3F
0	1	0	0	0	0	0	0	1.15000	40
0	1	0	0	0	0	0	1	1.14375	41
0	1	0	0	0	0	1	0	1.13750	42
0	1	0	0	0	0	1	1	1.13125	43
0	1	0	0	0	1	0	0	1.12500	44
0	1	0	0	0	1	0	1	1.11875	45
0	1	0	0	0	1	1	0	1.11250	46
0	1	0	0	0	1	1	1	1.10625	47
0	1	0	0	1	0	0	0	1.10000	48
0	1	0	0	1	0	0	1	1.09375	49
0	1	0	0	1	0	1	0	1.08750	4A
0	1	0	0	1	0	1	1	1.08125	4B
0	1	0	0	1	1	0	0	1.07500	4C
0	1	0	0	1	1	0	1	1.06875	4D
0	1	0	0	1	1	1	0	1.06250	4E
0	1	0	0	1	1	1	1	1.05625	4F
0	1	0	1	0	0	0	0	1.05000	50
0	1	0	1	0	0	0	1	1.04375	51
0	1	0	1	0	0	1	0	1.03750	52
0	1	0	1	0	0	1	1	1.03125	53

NCP81022

Table 1. SVI2 VID CODES

VID7	VID6	VID5	VID4	VID3	VID2	VID1	VID0	Voltage (V)	HEX
0	1	0	1	0	1	0	0	1.02500	54
0	1	0	1	0	1	0	1	1.01875	55
0	1	0	1	0	1	1	0	1.01250	56
0	1	0	1	0	1	1	1	1.00625	57
0	1	0	1	1	0	0	0	1.00000	58
0	1	0	1	1	0	0	1	0.99375	59
0	1	0	1	1	0	1	0	0.98750	5A
0	1	0	1	1	0	1	1	0.98125	5B
0	1	0	1	1	1	0	0	0.97500	5C
0	1	0	1	1	1	0	1	0.96875	5D
0	1	0	1	1	1	1	0	0.96250	5E
0	1	0	1	1	1	1	1	0.95625	5F
0	1	1	0	0	0	0	0	0.95000	60
0	1	1	0	0	0	0	1	0.94375	61
0	1	1	0	0	0	1	0	0.93750	62
0	1	1	0	0	0	1	1	0.93125	63
0	1	1	0	0	1	0	0	0.92500	64
0	1	1	0	0	1	0	1	0.91875	65
0	1	1	0	0	1	1	0	0.91250	66
0	1	1	0	0	1	1	1	0.90625	67
0	1	1	0	1	0	0	0	0.90000	68
0	1	1	0	1	0	0	1	0.89375	69
0	1	1	0	1	0	1	0	0.88750	6A
0	1	1	0	1	0	1	1	0.88125	6B
0	1	1	0	1	1	0	0	0.87500	6C
0	1	1	0	1	1	0	1	0.86875	6D
0	1	1	0	1	1	1	0	0.86250	6E
0	1	1	0	1	1	1	1	0.85625	6F
0	1	1	1	0	0	0	0	0.85000	70
0	1	1	1	0	0	0	1	0.84375	71
0	1	1	1	0	0	1	0	0.83750	72
0	1	1	1	0	0	1	1	0.83125	73
0	1	1	1	0	1	0	0	0.82500	74
0	1	1	1	0	1	0	1	0.81875	75
0	1	1	1	0	1	1	0	0.81250	76
0	1	1	1	0	1	1	1	0.80625	77
0	1	1	1	1	0	0	0	0.80000	78
0	1	1	1	1	0	0	1	0.79375	79
0	1	1	1	1	0	1	0	0.78750	7A
0	1	1	1	1	0	1	1	0.78125	7B
0	1	1	1	1	1	0	0	0.77500	7C
0	1	1	1	1	1	0	1	0.76875	7D

NCP81022

Table 1. SVI2 VID CODES

VID7	VID6	VID5	VID4	VID3	VID2	VID1	VID0	Voltage (V)	HEX
0	1	1	1	1	1	1	0	0.76250	7E
0	1	1	1	1	1	1	1	0.75625	7F
1	0	0	0	0	0	0	0	0.75000	80
1	0	0	0	0	0	0	1	0.74375	81
1	0	0	0	0	0	1	0	0.73750	82
1	0	0	0	0	0	1	1	0.73125	83
1	0	0	0	0	1	0	0	0.72500	84
1	0	0	0	0	1	0	1	0.71875	85
1	0	0	0	0	1	1	0	0.71250	86
1	0	0	0	0	1	1	1	0.70625	87
1	0	0	0	1	0	0	0	0.70000	88
1	0	0	0	1	0	0	1	0.69375	89
1	0	0	0	1	0	1	0	0.68750	8A
1	0	0	0	1	0	1	1	0.68125	8B
1	0	0	0	1	1	0	0	0.67500	8C
1	0	0	0	1	1	0	1	0.66875	8D
1	0	0	0	1	1	1	0	0.66250	8E
1	0	0	0	1	1	1	1	0.65625	8F
1	0	0	1	0	0	0	0	0.65000	90
1	0	0	1	0	0	0	1	0.64375	91
1	0	0	1	0	0	1	0	0.63750	92
1	0	0	1	0	0	1	1	0.63125	93
1	0	0	1	0	1	0	0	0.62500	94
1	0	0	1	0	1	0	1	0.61875	95
1	0	0	1	0	1	1	0	0.61250	96
1	0	0	1	0	1	1	1	0.60625	97
1	0	0	1	1	0	0	0	0.60000	98
1	0	0	1	1	0	0	1	0.59375	99
1	0	0	1	1	0	1	0	0.58750	9A
1	0	0	1	1	0	1	1	0.58125	9B
1	0	0	1	1	1	0	0	0.57500	9C
1	0	0	1	1	1	0	1	0.56875	9D
1	0	0	1	1	1	1	0	0.56250	9E
1	0	0	1	1	1	1	1	0.55625	9F
1	0	1	0	0	0	0	0	0.55000	A0
1	0	1	0	0	0	0	1	0.54375	A1
1	0	1	0	0	0	1	0	0.53750	A2
1	0	1	0	0	0	1	1	0.53125	A3
1	0	1	0	0	1	0	0	0.52500	A4
1	0	1	0	0	1	0	1	0.51875	A5
1	0	1	0	0	1	1	0	0.51250	A6
1	0	1	0	0	1	1	1	0.50625	A7

NCP81022

Table 1. SVI2 VID CODES

VID7	VID6	VID5	VID4	VID3	VID2	VID1	VID0	Voltage (V)	HEX
1	0	1	0	1	0	0	0	0.50000	A8
1	0	1	0	1	0	0	1	0.49375	A9
1	0	1	0	1	0	1	0	0.48750	AA
1	0	1	0	1	0	1	1	0.48125	AB
1	0	1	0	1	1	0	0	0.47500	AC
1	0	1	0	1	1	0	1	0.46875	AD
1	0	1	0	1	1	1	0	0.46250	AE
1	0	1	0	1	1	1	1	0.45625	AF
1	0	1	1	0	0	0	0	0.45000	B0
1	0	1	1	0	0	0	1	0.44375	B1
1	0	1	1	0	0	1	0	0.43750	B2
1	0	1	1	0	0	1	1	0.43125	B3
1	0	1	1	0	1	0	0	0.42500	B4
1	0	1	1	0	1	0	1	0.41875	B5
1	0	1	1	0	1	1	0	0.41250	B6
1	0	1	1	0	1	1	1	0.40625	B7
1	0	1	1	1	0	0	0	0.40000	B8
1	0	1	1	1	0	0	1	0.39375	B9
1	0	1	1	1	0	1	0	0.38750	BA
1	0	1	1	1	0	1	1	0.38125	BB
1	0	1	1	1	1	0	0	0.37500	BC
1	0	1	1	1	1	0	1	0.36875	BD
1	0	1	1	1	1	1	0	0.36250	BE
1	0	1	1	1	1	1	1	0.35625	BF
1	1	0	0	0	0	0	0	0.35000	C0
1	1	0	0	0	0	0	1	0.34375	C1
1	1	0	0	0	0	1	0	0.33750	C2
1	1	0	0	0	0	1	1	0.33125	C3
1	1	0	0	0	1	0	0	0.32500	C4
1	1	0	0	0	1	0	1	0.312875	C5
1	1	0	0	0	1	1	0	0.31250	C6
1	1	0	0	0	1	1	1	0.30625	C7
1	1	0	0	1	0	0	0	0.30000	C8
1	1	0	0	1	0	0	1	0.29375	C9
1	1	0	0	1	0	1	0	0.28750	CA
1	1	0	0	1	0	1	1	0.28125	CB
1	1	0	0	1	1	0	0	0.27500	CC
1	1	0	0	1	1	0	1	0.26875	CD
1	1	0	0	1	1	1	0	0.26250	CE
1	1	0	0	1	1	1	1	0.25625	CF
1	1	0	1	0	0	0	0	0.25000	D0
1	1	0	1	0	0	0	1	0.24375	D1

NCP81022

Table 1. SVI2 VID CODES

VID7	VID6	VID5	VID4	VID3	VID2	VID1	VID0	Voltage (V)	HEX
1	1	0	1	0	0	1	0	0.23750	D2
1	1	0	1	0	0	1	1	0.23125	D3
1	1	0	1	0	1	0	0	0.22500	D4
1	1	0	1	0	1	0	1	0.21875	D5
1	1	0	1	0	1	1	0	0.21250	D6
1	1	0	1	0	1	1	1	0.20625	D7
1	1	0	1	1	0	0	0	0.20000	D8
1	1	0	1	1	0	0	1	0.19375	D9
1	1	0	1	1	0	1	0	0.18750	DA
1	1	0	1	1	0	1	1	0.18125	DB
1	1	0	1	1	1	0	0	0.17500	DC
1	1	0	1	1	1	0	1	0.16875	DD
1	1	0	1	1	1	1	0	0.16250	DE
1	1	0	1	1	1	1	1	0.15625	DF
1	1	1	0	0	0	0	0	0.15000	E0
1	1	1	0	0	0	0	1	0.14375	E1
1	1	1	0	0	0	1	0	0.13750	E2
1	1	1	0	0	0	1	1	0.13125	E3
1	1	1	0	0	1	0	0	0.12500	E4
1	1	1	0	0	1	0	1	0.11875	E5
1	1	1	0	0	1	1	0	0.11250	E6
1	1	1	0	0	1	1	1	0.10625	E7
1	1	1	0	1	0	0	0	0.10000	E8
1	1	1	0	1	0	0	1	0.09375	E9
1	1	1	0	1	0	1	0	0.08750	EA
1	1	1	0	1	0	1	1	0.08125	EB
1	1	1	0	1	1	0	0	0.07500	EC
1	1	1	0	1	1	0	1	0.06875	ED
1	1	1	0	1	1	1	0	0.06250	EE
1	1	1	0	1	1	1	1	0.05625	EF
1	1	1	1	0	0	0	0	0.05000	F0
1	1	1	1	0	0	0	1	0.04375	F1
1	1	1	1	0	0	1	0	0.03750	F2
1	1	1	1	0	0	1	1	0.03125	F3
1	1	1	1	0	1	0	0	0.02500	F4
1	1	1	1	0	1	0	1	0.01875	F5
1	1	1	1	0	1	1	0	0.01250	F6
1	1	1	1	0	1	1	1	0.00625	F7
1	1	1	1	1	0	0	0	OFF	F8
1	1	1	1	1	0	0	1	OFF	F9
1	1	1	1	1	0	1	0	OFF	FA
1	1	1	1	1	0	1	1	OFF	FB

NCP81022

Table 1. SVI2 VID CODES

VID7	VID6	VID5	VID4	VID3	VID2	VID1	VID0	Voltage (V)	HEX
1	1	1	1	1	1	0	0	OFF	FC
1	1	1	1	1	1	0	1	OFF	FD
1	1	1	1	1	1	1	0	OFF	FE
1	1	1	1	1	1	1	1	OFF	FF

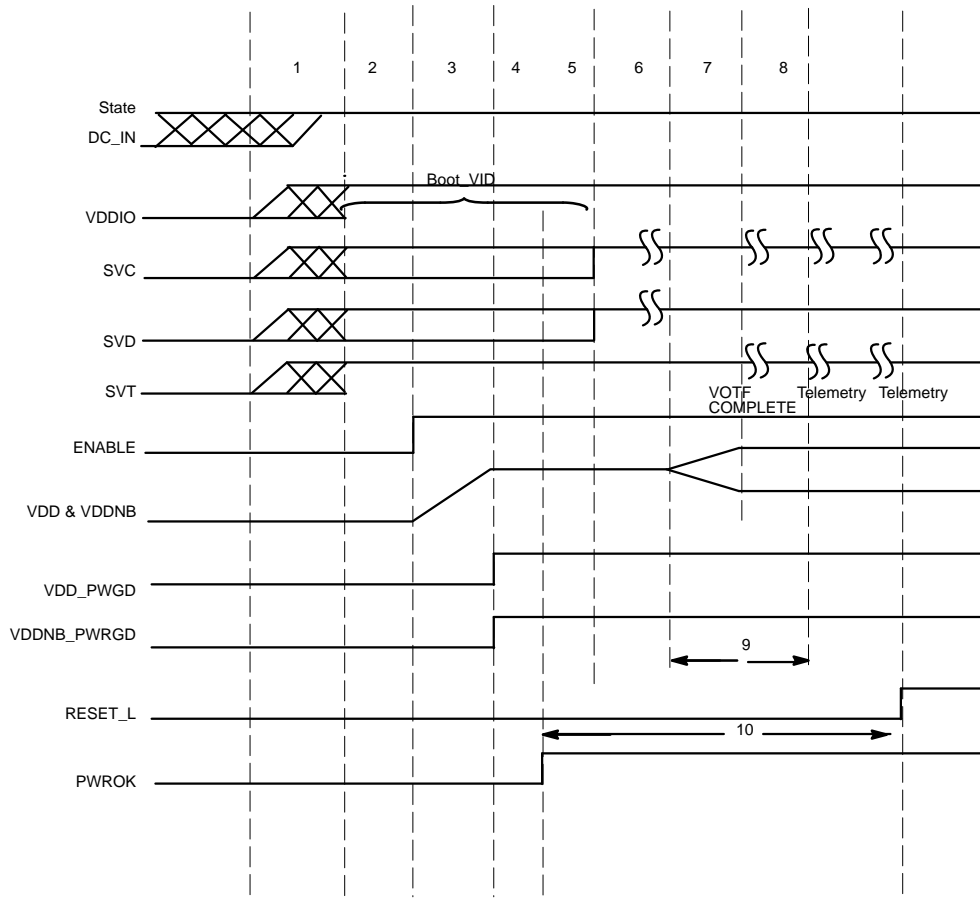

Figure 3. Start Up Timing Diagram

NCP81022

SVI2 INTERFACE

SVD SERIAL PACKET BIT DESCRIPTION

Bit	Default	Description
1:5	11000	Start code
6	1	VDD domain selector bit, if set then the following two data bytes contain the VID for VDD, the PSI state for VDD and the loadline slope trim and offset
7	0	VDDNB domain selector bit, if set then the following two data bytes contain the VID for VDDNB, the PSI state for VDDNB and the loadline slope trim and offset
8	0	
9	0	ACK
10	0	PSI0 power state indicator level 0. when this signal is asserted the NCP81022 is in a lower power state, and phase shedding is initialized.
11:17	XXXXXXX	VID code [7:1] see table 2
18	0	ACK
19	X	VID code LSB [0] see table 2
20		PSI1, when this bit is asserted the NCP81022 is in a low power state and operated in diode mode emulation mode
21	1	TFN, this is an active high signal that allows the processor to control the telemetry functionality of the NCP81022.
22:24	011	Loadline slope Trim [2:0]
25:26	10	Offset Trim [1:0]
27	0	ACK

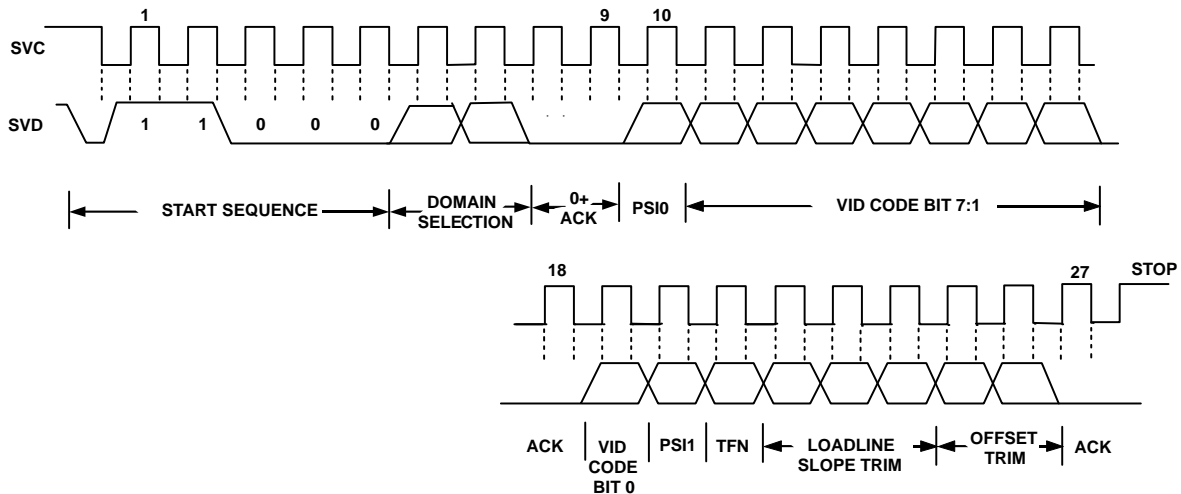

Figure 4. SVD Packet Structure

SVI2 Interface

The NCP81022 is design to accept commands over AMD's SVI2 bus. The communication is accomplished using three lines, a data line SVD, a clock line SVC and a telemetry line SVT. The SVD line can be used not only to set the voltage level of the Main rail and North bridge rail, but can also set the load line slope, programmed offset and also the PSI (power state indicator bits). The SVT line from the NCP81022 communicates voltage, current and status updates back to the processor.

Power State Indicator (PSI)

The SVI2 protocol defines two PSI levels, PSI0 and PSI1. These are active low signals which indicate when the NCP81022 can enter low power states to improve system efficiency and performance. Increasing levels of PSI state indicates low current consumption of the processor.

NCP81022

It is possible for the processor to assert PSI0 and PSI1 out of order i.e. to enter PSI1 prior to PSI0 however; PSI0 always takes priority over PSI1.

With increasing load current demand the number of active phases increase instantaneous. The NCP81022 can potentially change from single-phase to user-configured multiphase operation in a single step, depending on PSI state.

PSI0 is activated once the system power is in the region of 20–30 A, in this mode the NCP81022 controller reduces the number of phases in operation thus reducing switching losses of the system. If the current continues to drop to 1–3 A PSI1 is asserted and the NCP81022 enters diode emulation mode, operating in single phase mode. See below table for PSI mode operation.

PSI0#	PSI1#	Phase
0	0	1-Phase DCM
0	1	1-Phase CCM
1	0	Full phase mode
1	1	Full phase mode

Telemetry

The TFN bit along with the VDD and VDDNB domain selectors are used to change the functionality of the telemetry. See table below for description.

TFN = 1		Description
VDD	VDDNB	
0	1	Telemetry is in voltage and current mode. V&I is sent back for both VDD and VDDNB rails
0	0	Telemetry is in voltage only mode. Voltage information is sent back for both VDD and VDDNB rails
1	0	Telemetry is disabled
1	1	Reserved for future use

Loadline Slope

Within the SVI2 protocol the NCP81022 controller has the ability to manipulate the loadline slope of both the VDD and VDDNB rails independently of each other, when Enable and PWROK are asserted. Loadline slope trim information is transmitted in 3 bits , 22:24, over the SVD packet. Please see table below for description.

Loadline Slope Trim [0:2]	Description
000	Remove all LL droop from output
001	LL slope 12.9%
010	LL slope 25.8%
011	LL slope (Default 38.7%)
100	LL slope 51.6%
101	LL slope 64.8%
110	LL slope 77.4%
111	LL slope 90.2%

NCP81022

Offset Trim

Within the SVI2 protocol the NCP81022 controller has the ability to manipulate the offset of both the VDD and VDDNB rails independently of each other, when Enable and PWROK are asserted. Descriptions of offset codes are described below.

Offset Trim [1:0]	Description
00	0 offset
01	Initial offset -25 mV
10	Use initial offset (default)
11	Initial offset +25 mV

SVT Serial Packet

The NCP81022 has the ability to sample and report voltage and current for both the VDD and VDDNB domain. This information is reported serially over the SVT line which is clocked using the processor driven SVC line. When the PWROK is deasserted, the NCP81022 is not collecting or reporting telemetry information. When PWROK is asserted, the telemetry information reported back is as described below. If the NCP81022 is configured in voltage only telemetry then the sampled voltage for VDD and the sampled voltage for the VDDNB are sent together in every SVT telemetry packet.

Parameter	Value	Unit
Number of voltage Bits	9	Bits
Maximum reporting Voltage	3.15	V
Minimum reported Voltage	0.00	V
Voltage resolution	6.25	mV
Voltage accuracy from 1.2 V to 800 mV	±1	LSB
Voltage accuracy for voltages greater than 1.2 V and less than 800 mV	±2	LSB
Recommended voltage moving average window size	50	µs
Minimum voltage only telemetry reporting rate	20	kHz
Number of bits in current data	8	Bits
Max reported current (FFh = OCP)	100	% of IDD spike _ocp
Max reported current (00h)	0	% of IDD spike _ocp

If the NCP81022 is configured in voltage and current mode then the samples voltage and current information for VDD is sent out in one SVT telemetry packet while the voltage and current information for the VDDNB domain is sent out in the next SVT telemetry packet. The telemetry report rate while the NCP81022 is in current and voltage mode, is double that which is observed in voltage only mode. The reported voltage and current are moving average representations.

Bit	Description		Bit	
0	SVT0	See table below for description	10	Voltage Bit 0
1	SVT1		11	Voltage Bit 8 '0' in V and I mode
2	Voltage Bit 8		12	Voltage or current Bit 7
3	Voltage Bit 7		13	Voltage or current Bit 6
4	Voltage Bit 6		14	Voltage or current Bit 5
5	Voltage Bit 5		15	Voltage or current Bit 4
6	Voltage Bit 4		16	Voltage or current Bit 3
7	Voltage Bit 3		17	Voltage or current Bit 2
8	Voltage Bit 2		18	Voltage or current Bit 1
9	Voltage Bit 1		19	Voltage or current Bit 0

NCP81022

SVT0, SVT1	Description
0,0	Telemetry packet belongs to the VDD domain and in V&I mode.
0,1	Telemetry packet belongs to the VDDNB domain and in V&I mode.
1,0	VOTF Complete, a stop immediately follows these two bits during the next SVC high period. Telemetry data does not follow this bit configuration
1,1	Telemetry package in voltage representation only. (default)

SVI2 VR to Processor Data Communication

As described previously the NCP81022 has the ability to send digitally encoded voltage and current values for the VDD and VDDNB domains to the processor, it also has the capability to send VID On The Fly (VOTF) complete mechanism. The processor uses this information as an indicator for when the VDD, VDDNB are independently, or collectively, at the requested stepped-up VID voltage. The VOTF complete mechanism is not used for VID changes to lower or for repeated VID codes.

VOTF Complete is transmitted as an SVT packet. Since a VOTF request could apply to one or two voltage domains, rules are suggested below to handle these cases.

VID Change	Offset Change	Loadline Change	VOFT Timing	Force or Decay Change
UP	Unchanged	Unchanged	After slewing	Force voltage change
Down	Unchanged	Unchanged	NO VOTF	Voltage Decay
X	UP	Unchanged	After slewing	Force voltage change
X	Down	Unchanged	After slewing	Force voltage change
X	Unchanged	Up	After slewing	Force voltage change
X	Unchanged	Down	After slewing	Force voltage change

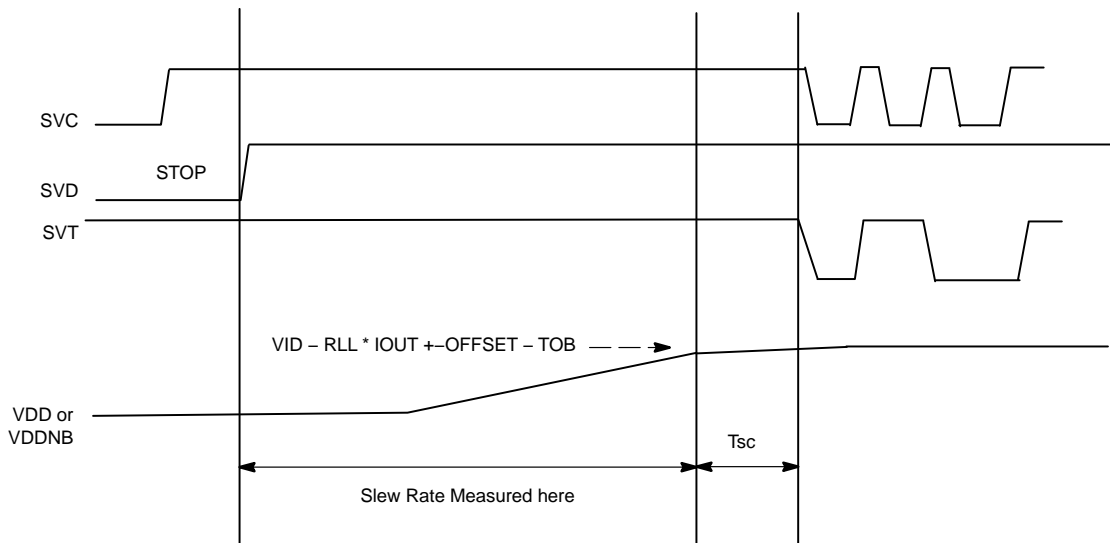

Figure 5. Slew Rate Timing

*Max Tsc = 5 μs

- Telemetry takes priority over VOTF Complete signals
- VOTF complete can be sent if the net voltage change is 0 or negative
- VOTF Complete is only used to indicate that a rail(s) has finish slewing to a higher voltage.
- If a VOTF request for a higher voltage is sent for both VDD and VDDNB rails, but only domain will go up in voltage then the returned VOTF Complete will indicate that the increasing domain has finished slewing
- If the processor starts a VOTF request but the VOTF is incomplete then the NCP81022 will not sent the VOTF Complete sequence until after the new VOTF request.

NCP81022

- If the processor is sending a SVD packet when the NCP81022 is sending telemetry packet to send, then the NCP81022 waits to send the telemetry until after the SVD packet has stopped transmitting.
- If the processor stops sending the SVD packet while the NCP81022 is sending telemetry then no action has to be taken, the NCP81022 shifts in the new SVD packet and finishes sending the telemetry while the processor is sending the SVD packet.
- SVT packets are not sent while PWROK is deasserted
- The NCP81022 will not collect or send telemetry data when telemetry functionality is disabled by the TFN bits

The following timing diagrams cover the SVC, SVD and SVT timing when PWROK is asserted and data is being transmitted, the table that follows defines the min and max value for each timing specification.

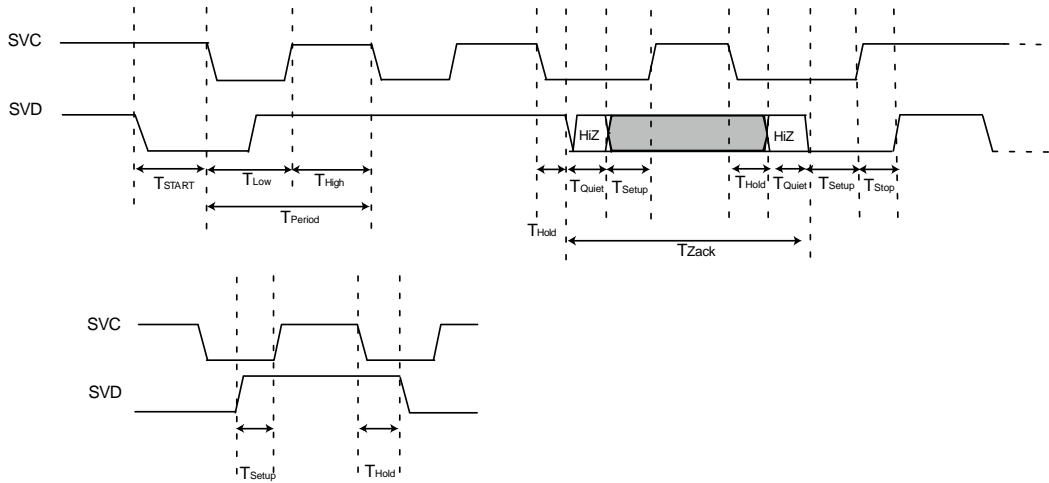

Figure 6. SDV SVC Timing

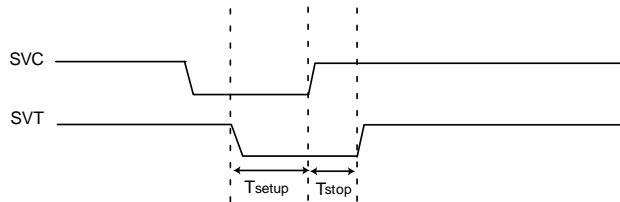

Figure 7. SVT Stop Timing

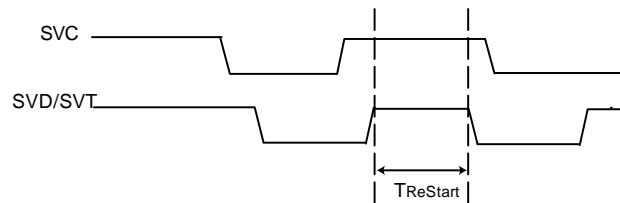

Figure 8. SVD or SVT Re-Start Timing

NCP81022

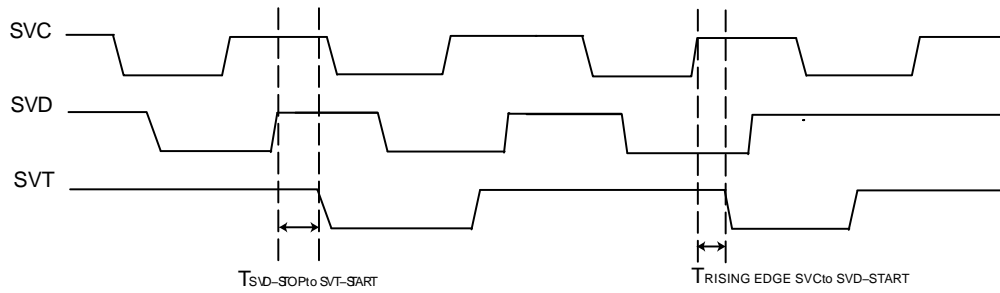

Figure 9. SVT start and Stop timing

Table 2. SVI2 BUS TIMING PARAMETERS FOR 3.33 MHz OR 20 MHz OPERATION

Parameter	Min	Max	Unit
T _{PERIOD}	50	TDC	ns
SVC Frequency	TDC	20	MHz
T _{HIGH} SVC High Time	20		ns
T _{Low} SVC Low Time	30		ns
T _{setup} (SVD, SVT Setup time to SVC rise edge)	5	10	ns
T _{Hold} (SVD, SVT Hold time from SVC falling edge)	5	10	ns
T _{Quiet} (Time neither processor nor VR is driving the SVD line)	10		ns
T _{ZACK} (total time processor tristates SVD)	50		ns
T _{START}	20		ns
T _{STOP}	10		ns
T _{ReSTART} (Time Between Stop and Start on SVD)	50		ns
T _{ReSTART} (Time Between Stop and Start on SVD)	50		ns
T _{SVD-STOP to SVT-START} (Time Between SVD stop and SVT Start)	80		ns
T _{Rising Edge SVC to SVT-Start} (Time between Rising Edge of SVC after last SVT bit to SVD start)	20		ns
SVC, SVD, SVT Fall Time VOH_DC to VOL_DC		1	ns
SVC, SVD, SVT Rise Time VOH_DC to VOL_DC		1	ns
T _{Skew-SVC-SVD} The skew between SVC, SVD as seen at the NCP81022; dictated by layout and tested by simulation		1	ns
T _{Skew-SVC-SVD} The skew between SVC, SVD as seen at the Processor; dictated by layout and tested by measurement		2	ns
T _{Propagation} The propagation delay of SVC, SVD, SVT; measured from the transmitter to the receiver		2	ns
SVC glitches filter width. NCP81022's glitch filter will reject any SVC transition that persists for shorter periods than this	3	5	ns

Slew Rate

Slew rate is programmable on power up; a resistor from the SR pin to ground sets the slew rate. Each rail can be programmed independently between 10 mV/μs, see table below for resistor values.

Slew Rate	Resistance (Ω)
10 mV/μs	10k
20 mV/μs	25k
30 mV/μs	45k

NCP81022

BOOT VOLTAGE PROGRAMMING

The NCP81022 has a VBOOT voltage register that can be externally programmed for both Main Rail and North Bridge boot-up output voltage. The VBOOT voltage can be programmed when PWROK is deasserted, through the logic levels present on SVC and SVD. The table below defines the Boot-VID codes

BOOT VOLTAGE TABLE:

SVC	SVD	Boot Voltage
0	0	1.1
0	1	1.0
1	0	0.9
1	1	0.8

ADDRESSING PROGRAMMING

The NCP81102 supports eight possible SMBus Addresses. Pin 28 (PWM4) is used to set the SMBus Address. On power up a 10 µA current is sourced from this pin through a resistor connected to this pin and the resulting voltage is measured. The Table below provides the resistor values for each corresponding SMBus Address. The address value is latched at startup.

Table 3. SMBus ADDRESS

Resistor Value	SMBus (Hex)
10k	20
25k	21
45k	22
70k	23
95k	24
125k	25
165k	26
220k	27

Programming the ICC_Max

A resistor to ground on the IMAX pin program the ICC_Max value at the time the NCP81022 is enabled. 10 µA is sourced from this pin to generate a voltage on the program resistor. The resistor value should be no less than 10k.

$$R_{\text{ICC_MAX}} = \frac{(2 * \text{ICC_MAX})}{(10\mu * 256)}$$

Remote Sense Amplifier

A high performance high input impedance true differential amplifier is provided to accurately sense the output voltage of the regulator. The VSP and VSN inputs should be connected to the regulator's output voltage sense points. The remote sense amplifier takes the difference of the output voltage with the DAC voltage and adds the droop voltage to:

$$V_{\text{DIFF}} = (V_{\text{VSP}} - V_{\text{VSN}}) + (1.3 \text{ V} - V_{\text{DAC}}) + (V_{\text{DROOP}} - V_{\text{CSREF}})$$

This signal then goes through a standard error compensation network and into the inverting input of the error amplifier. The non-inverting input of the error amplifier is connected to the same 1.3 V reference used for the differential sense amplifier output bias.

High Performance Voltage Error Amplifier

A high performance error amplifier is provided for high bandwidth transient performance. A standard type 3 compensation circuit is normally used to compensate the system.

Differential Current Feedback Amplifiers

Each phase has a low offset differential amplifier to sense that phase current for current balance and per phase OCP protection during soft-start. The inputs to the CSREF and CSPx pins are high impedance inputs. It is recommended that any external filter resistor RCSN not exceed 10 kΩ to avoid offset issues with leakage current. It is also recommended that the voltage sense

element be no less than 0.5 mΩ for accurate current balance, user care should be taken in board design if lower DCR inductor are used as this may affect the current balance in light load conditions. Fine tuning of this time constant is generally not required.

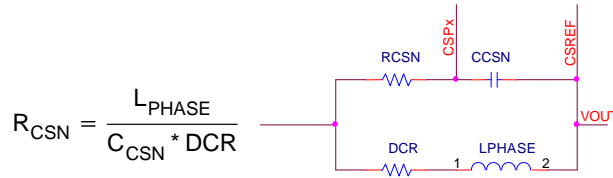

Figure 10. Differential Current Feedback

The individual phase current is summed into to the PWM comparator feedback in this way current is balanced is via a current mode control approach.

Total Current Sense Amplifier

The NCP81022 uses a patented approach to sum the phase currents into a single temperature compensated total current signal. This signal is then used to generate the output voltage droop, total current limit, and the output current monitoring functions. The total current signal is floating with respect to CSREF. The current signal is the difference between CSCOMP and CSREF. The Ref (n) resistors sum the signals from the output side of the inductors to create a low impedance virtual ground. The amplifier actively filters and gains up the voltage applied across the inductors to recover the voltage drop across the inductor series resistance (DCR). Rth is placed near an inductor to sense the temperature of the inductor. This allows the filter time constant and gain to be a function of the Rth NTC resistor and compensate for the change in the DCR with temperature.

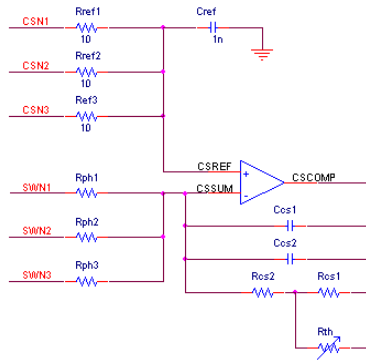

Figure 11. Current Sense Amplifier

The DC gain equation for the current sensing:

$$V_{CSCOMP-CSREF} = - \frac{Rcs2 + \frac{Rcs1 \cdot Rth}{Rcs1 + Rth}}{Rph} * (I_{out_Total} * DCR)$$

Set the gain by adjusting the value of the Rph resistors. The DC gain should set to the output voltage droop. If the voltage from CSCOMP to CSREF is less than 100mV then it is recommended to increase the gain of the CSCOMP amp and add a resistor divider to the Droop pin filter. This is required to provide a good current signal to offset voltage ratio for the ILIM pin. When no droop is needed, the gain of the amplifier should be set to provide ~100 mV across the current limit programming resistor at full load. The values of Rcs1 and Rcs2 are set based on the 220k NTC and the temperature effect of the inductor and should not need to be changed. The NTC should be placed near the closest inductor. The output voltage droop should be set with the droop filter divider.

The pole frequency in the CSCOMP filter should be set equal to the zero from the output inductor. This allows the circuit to recover the inductor DCR voltage drop current signal. Ccs1 and Ccs2 are in parallel to allow for fine tuning of the time constant using commonly available values. It is best to fine tune this filter during transient testing.

$$F_z = \frac{DCR@25^\circ C}{2 * \pi * L_{Phase}}$$

$$F_p = \frac{1}{2 * \pi * \left(Rcs2 + \frac{Rcs1 \cdot Rth@25^\circ C}{Rcs1 + Rth@25^\circ C} \right) * (Ccs1 + Ccs2)}$$

NCP81022

Programming the Current Limit

The current-limit thresholds are programmed with a resistor between the ILIM and CSCOMP pins. The ILIM pin mirrors the voltage at the CSREF pin and the current limit comparators. Set the value of the current limit through CSREF– CSCOMP voltage at I_{out_LIMIT} condition as shown below:

$$R_{ILIM} = \frac{\frac{R_{cs2} + \frac{R_{cs1} \cdot R_{th}}{R_{cs1} + R_{th}}}{R_{ph}} \cdot (I_{out_LIMIT} \cdot DCR)}{10 \mu A} \quad \text{or} \quad R_{ILIM} = \frac{V_{CSREF-CSCOMP@ILIMIT}}{10 \mu A}$$

Programming DROOP and DAC feedforward

Programming Rdroop sets the gain of the DAC feed-forward and Cdroop provides the time constant to cancel the time constant of the system per the equations below. Cout_total is the total output capacitance of the system design.

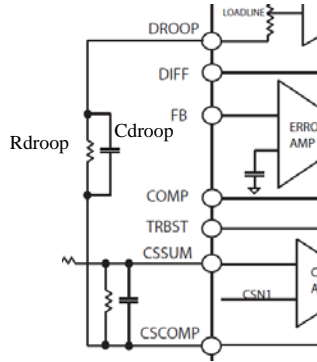

$$R_{droop} = (C_{out_total}) \cdot loadline \cdot 453.6 \cdot 10^6$$

$$C_{droop} = (loadline \cdot (C_{out_total})) / R_{droop}$$

Figure 12. Droop RC

Programming IOOUT

The IOOUT pin sources a current equal to the ILIM sink current gained by the IOOUT Current Gain. The voltage on the IOOUT pin is monitored by the internal A/D converter and should be scaled with an external resistor to ground such that a load equal to ICCMAX generates a 2 V signal on IOOUT. A pull-up resistor from 5 V VCC can be used to offset the IOOUT signal positive if needed.

$$R_{IOOUT} = \frac{2.0 V \cdot R_{LIMIT}}{10 \cdot \frac{R_{cs2} + \frac{R_{cs1} \cdot R_{th}}{R_{cs1} + R_{th}}}{R_{ph}} \cdot (I_{out_ICCMAX} \cdot DCR)}$$

Precision Oscillator

A programmable precision oscillator is provided. The clock oscillator serves as the master clock to the ramp generator circuit. This oscillator is programmed by a resistor to ground on the ROSC pin. The oscillator can also be programmed over the SMBus interface through register 0xF7. The oscillator frequency range is between 200 kHz/phase to 1 MHz/phase in 32 steps. The ROSC pin provides approximately 2 V out and the source current is mirrored into the internal ramp oscillator.

NCP81022

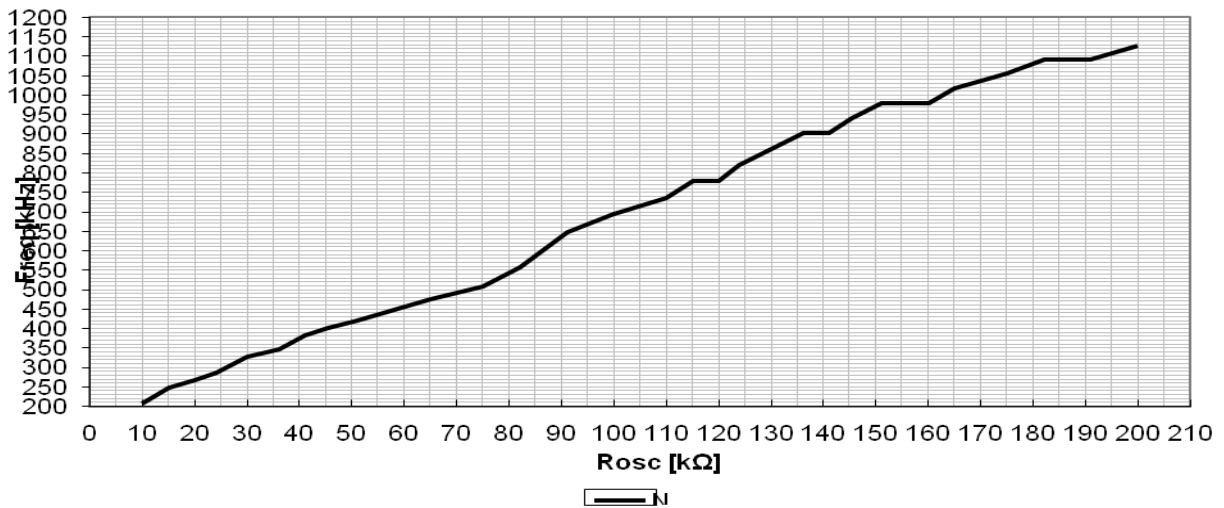

Figure 13. NCP81022 Operating Frequency vs. Rosc

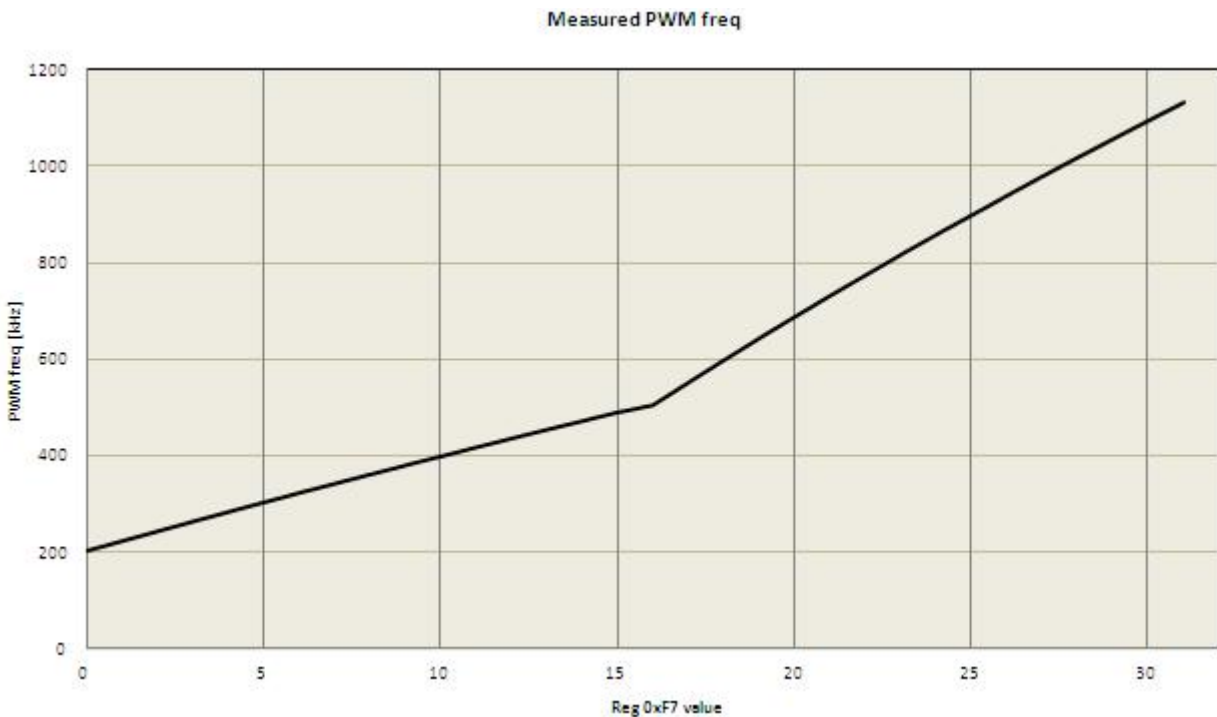

Figure 14. PWM vs. Register Code

The oscillator generates triangle ramps that are 0.5~2.5 V in amplitude depending on the VRMP pin voltage to provide input voltage feed forward compensation. The ramps are equally spaced out of phase with respect to each other and the signal phase rail is set half way between phases 1 and 2 of the multi phase rail for minimum input ripple current.

Programming the Ramp Feed-Forward Circuit

The ramp generator circuit provides the ramp used by the PWM comparators. The ramp generator provides voltage feed-forward control by varying the ramp magnitude with respect to the VRMP pin voltage. The VRMP pin also has a 4 V UVLO function. The VRMP UVLO is only active after the controller is enabled. The VRMP pin is a high impedance input when the controller is disabled.

The PWM ramp time is changed according to the following,

$$V_{\text{RAMPpk=pkPP}} = 0.1 * V_{\text{VRMP}}$$

NCP81022

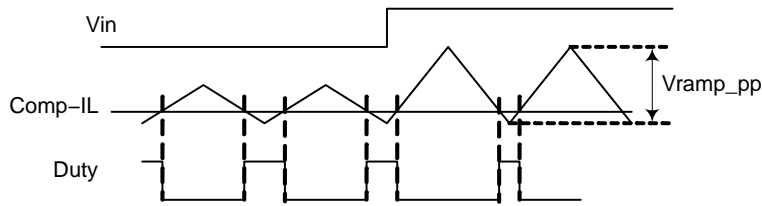

Figure 15. Ramp Feedforward

Programming TRBST#

The TRBST# pin provides a signal to offset the output after load release overshoot. This network should be fine tuned during the board tuning process and is only necessary in systems with significant load release overshoot. The TRBST# network allows maximum boost for low frequency load release events to minimize load release ringing back undershoot. The network time constants are set up to provide a TRBST# roll off at higher frequencies where it is not needed. $C_{boost1} \cdot R_{bst1}$ controls the time constant of the load release boost. This should be set to counter the under shoot after load release. $R_{bst1} + R_{bst2}$ controls the maximum amount of boost during rapid step loading. R_{bst2} is generally much larger than R_{bst1} . The $C_{boost2} \cdot R_{bst2}$ time constant controls the roll off frequency of the TRBST# function.

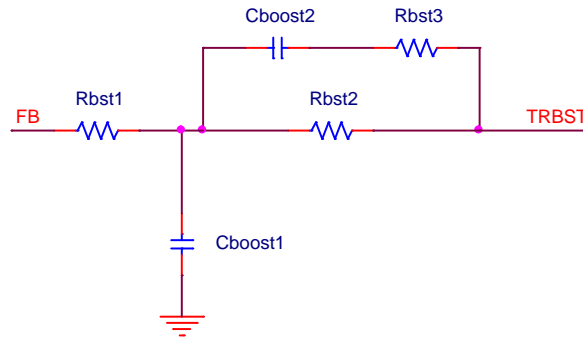

Figure 16. TRBST Circuit

PWM Comparators

During steady state operation, the duty cycle is centered on the valley of the triangle ramp waveform and both edges of the PWM signal are modulated. During a transient event the duty will increase rapidly and proportionally turning on all phases as the error amp signal increases with respect to the ramps to provide a highly linear and proportional response to the step load.

Phase Detection Sequence for Main Rail

During start-up, the number of operational phases and their phase relationship is determined by the internal circuitry monitoring the CSN Pins. Normally, NCP81022 main rail operates as a 4-phase PWM controller. Connecting CSN4 pin to VCC programs 3-phase operation, connecting CSN2 and CSN4 pin to VCC programs 2-phase operation, connecting CSN2, CSN3 and CSN4 pin to VCC programs 1-phase operation. Prior to soft start, while ENABLE is high, CSN4 to CSN2 pins sink approximately 50 μ A. An internal comparator checks the voltage of each pin versus a threshold of 4.5V. If the pin is tied to VCC, its voltage is above the threshold. Otherwise, an internal current sink pulls the pin to GND, which is below the threshold. PWM1 is low during the phase detection interval, which takes 30 μ s. After this time, if the remaining CSN outputs are not pulled to VCC, the 50 μ A current sink is removed, and NCP81022 main rail functions as normal 4 phase controller. If the CSNs are pulled to VCC, the 50 μ A current source is removed, and the outputs are driven into a high impedance state.

The PWM outputs are logic-level devices intended for driving fast response external gate drivers such as the NCP5901 and NCP5911. Because each phase is monitored independently, operation approaching 100% duty cycle is possible. In addition, more than one PWM output can be on at the same time to allow overlapping phases.

PHASE DETECTION

Number of phases	Programming pin CSNX	Unused pins
4+1	All CSN pin connected normally.	No unused pins
3+1	Connect CSN4 to VCC through a 2k resistor. All other CSN pins connected normally.	Float PWM4 Ground CSP4

NCP81022

PHASE DETECTION

Number of phases	Programming pin CSNX	Unused pins
2+1	Connect CSN2 and CSN4 to VCC through a 2k resistor. All other CSN pins connected normally.	Float PWM4 and PWM2 Ground CSP4, and CSP2
1+1	Connect CSN2, CSN3 and CSN4 to VCC through a 2k resistor. All other CSN pins connected normally.	Float PWM4, PWM3 and PWM2 Ground CSP4, CSP3 and CSP2
4+0	CSN1NB pulled to VCC through 2k resistor. All other CSN pins connected normally.	Float PWM1NB, Ilim NB, Diffout NB, Comp NB, TRBSTNB and CScompNB Ground IoutNB, DroopNB, FB NB, CSSUMNB, CSPNB and VDDNB
3+0	Connect CSN4 and CSN1NB to VCC through a 2k resistor. All other CSN pins connected normally.	Float PWM4, PWM1NB, Ilim NB, Diffout NB, Comp NB, TRBSTNB and CScompNB Ground CSP4, IoutNB, DroopNB, FB NB, CSSUMNB, CSPNB and VDDNB
2+0	Connect CSN2, CSN4 and CSN1NB to VCC through a 2k resistor. All other CSN pins connected normally.	Float PWM4, PWM2, PWM1NB, Ilim NB, Diffout NB, Comp NB, TRBSTNB and CScompNB Ground CSP4, CSP2, IoutNB, DroopNB, FB NB, CSSUMNB, CSPNB and VDDNB
1+0	Connect CSN2, CSN3, CSN4 and CSN1NB to VCC through a 2k resistor. CSN1 pin connected normally.	Float PWM4, PWM3, PWM2, PWM1NB, Ilim NB, Diffout NB, Comp NB, TRBSTNB and CScompNB Ground CSP4, CSP3, CSP2, IoutNB, DroopNB, FB NB, CSSUMNB, CSPNB and VDDNB

Protection Features

Output voltage out of regulation is defined as either a UVP or OVP event. The protection mechanism in case of either type of fault is described in this section.

Gate Driver UVLO Protection

The NCP811022 monitors Vcc and DRON signals during UVLO restart, as shown in Figure 17.

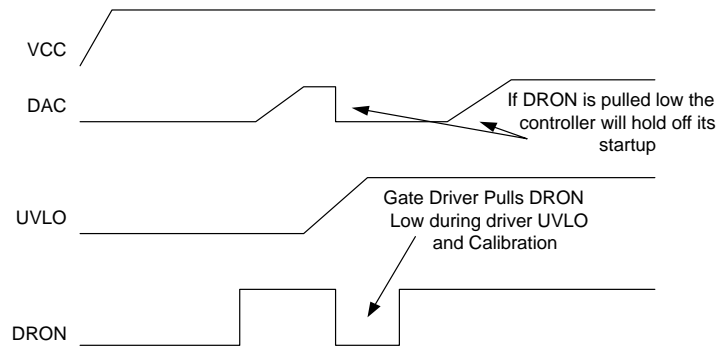

Figure 17. Gate Driver UVLO Restart

Soft Start

Soft start is implemented internally. A digital counter steps the DAC up from zero to the target voltage based on the predetermined slew rate programmed on startup. The controller enables and sets the PWM signal to the 2.0 V MID state to indicate that the drivers should be in diode mode. The COMP pin released to begin soft-start. The DAC will ramp from Zero to the target DAC codes and the PWM outputs will begin to fire. Each phase will move out of the MID state when the first PWM pulse is produced preventing the discharge of a pre-charged output.

NCP81022

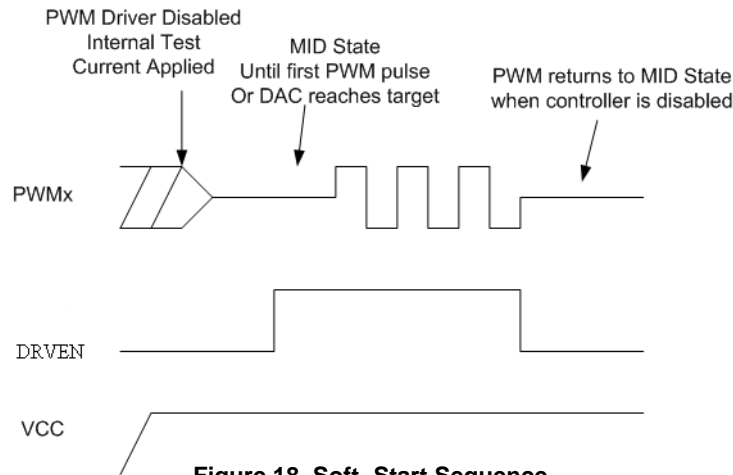

Figure 18. Soft-Start Sequence

Over Current Latch- Off Protection

The NCP81022 support **IDDSPIKE**, an amount of current drawn by the processor that exceeds the sustained design current limit, TDC, for a thermally significant period of time <10 ms. The NCP81022 incorporates a dual threshold current based protection mechanism for both the VDD and the VDDNB output to protect the NCP81022 if the output current exceeds TDC.

The NCP81022 provides two different types of current limit protection. During normal operation a programmable total current limit is provided that scales with the phase count during power saving operation. A second fixed per-phase current limit is provided for VID lower than 0.25 V, such as during soft-start.

The level of total current limit is set with the resistor from the ILIM pin to CSCOMP pin. Internally the current through ILIM pin is scaled and then compared to two current thresholds 10 μ A and 15 μ A, where 10 μ A threshold is scaled to indicate the 100% current limit and 15 μ A indicates the 150% current limit. If 100% current limit is exceeded, an internal latch-off counter starts. The controller shuts down if the over current fault is not removed after 50 μ s. If 150% current limit is exceeded, the controller shuts down immediately. To recover from an OCP fault the EN pin must be cycled low. The current limit is scaled when phase shedding is in operation. Phase shedding from 4-phase to single phase scales the current limit to its 1/4; phase shedding from 2-phase to single phase scales the current limit to its half.

During startup the per phase current limit is active to protect the individual output stages. This limit monitors the voltage drop across the DCR through the CSPx and CSREF pins. The minimum threshold is 36 mV.

Under Voltage Monitor

Both output, VDD and VDDNB, must be protected from an under-voltage fault, which is indicative of a short circuit fault. The UVP threshold is shown in the table below. The output voltage is monitored at the output of the differential amplifier for UVLO. If the output falls more than 300 mV below the DAC-DROOP voltage the UVLO comparator will trip sending the VDD_PWRGD/VDDNB_PWRGD signal low. If a UVP event occurs, the NCP81022 need to be re-enable by cycling the enable pin.

Over Voltage Protection

During normal operation the output voltage is monitored at the differential inputs VSP and VSN. If the output voltage exceeds the DAC voltage by approximately 325 mV, LGx from integrated drivers will be forced high and PWM/PWMA will be forced low when OVP is triggered. And then the DAC will ramp down to zero to avoid a negative output voltage spike during shutdown. When the DAC gets to zero, LGx will be forced high and PWM/PWMA will be forced low with DRON remaining high. To reset the part the EN pin must be cycled low.

NCP81022

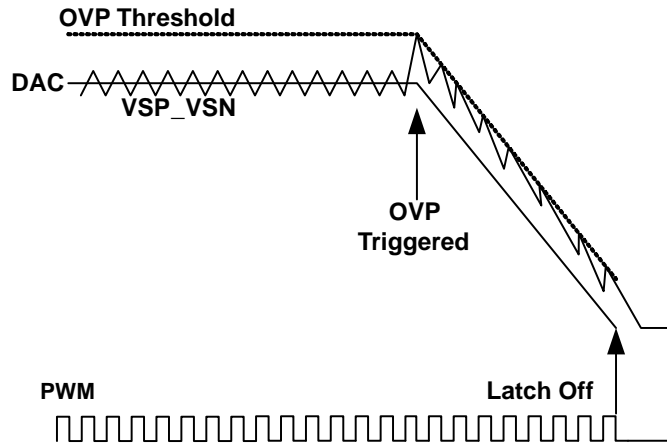

Figure 19. OVP Threshold Behavior

Parameter	Min	Typ	Max	Description
UVP Threshold	300 mV	325 mV	350 mV	Voltage below programmed VID
OVP Threshold	300 mV	325 mV	350 mV	Voltage below programmed VID
Non-Fault domain Power down or PWRGD Delay	1		10	μS

Layout Notes

The NCP81022 has differential voltage and current monitoring. This improves signal integrity and reduces noise issues related to layout for easy design use. To insure proper function there are some general rules to follow:

Careful layout in per phase and total current sensing are critical for jitter minimization, accurate current balancing and ILIM monitoring. Give the first priority in component placement and trace routing to per phase and total current sensing circuit. The per phase inductor current sense RC filters should always be placed as close to the CSREF and CSP pins on the controller as possible. The filter cap from CSCOMP to CSREF should also be close to the controller. The temperature-compensate resistor R_{TH} should be placed as close as possible to the Phase 1 inductor. The wiring path between R_{CSX} and R_{PHX} should be kept as short as possible and well away from switch node lines. The Refx resistors ($10\ \Omega$) connected to CSREF pin should be placed near the inductors to reduce the length of traces. The above layout notes are shown in the following diagram:

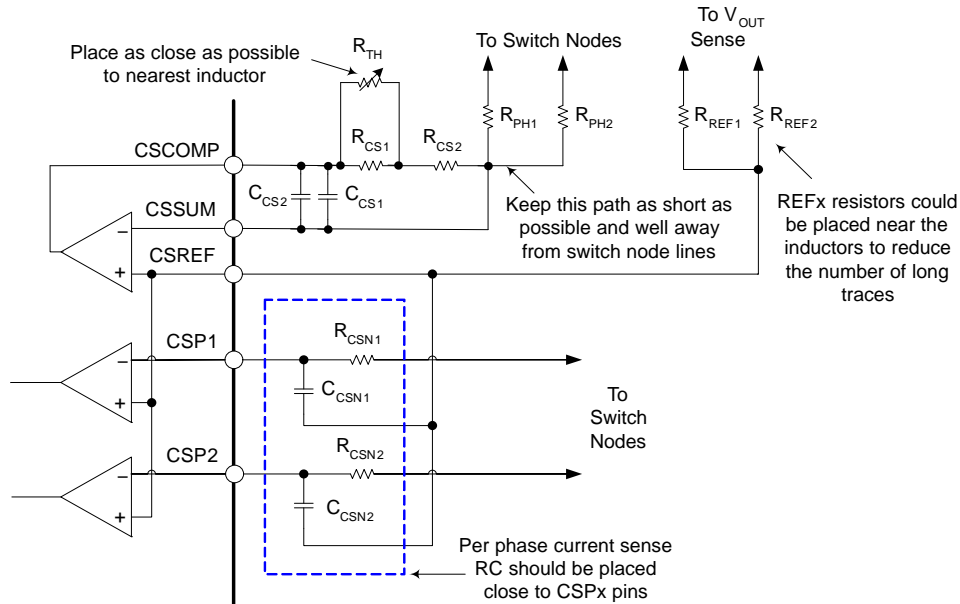

Figure 20.

NCP81022

Place the VCC decoupling caps as close as possible to the controller VCC pin. For any RC filter on the VCC and VDDBP pins, the resistor should be no higher than 2.2 Ω to prevent large voltage drop.

The small high feed back cap from COMP to FB should be as close to the controller as possible. Keep the FB traces short to minimize their capacitance to ground.

Digital Interface

Control of the NCP81022 is carried out using the Digital Interface.

The NCP81022 is connected to this bus as a slave device, under the control of a master controller.

Data is sent over the serial bus in sequences of nine clock pulses: eight bits of data followed by an acknowledge bit from the slave device. Transitions on the data line must occur during the low period of the clock signal and remain stable during the high period, because a low-to-high transition when the clock is high might be interpreted as a stop signal. The number of data bytes that can be transmitted over the serial bus in a single read or write operation is limited only by what the master and slave devices can handle.

1. When all data bytes have been read or written, stop conditions are established. In write mode, the master pulls the data line high during the tenth clock pulse to assert a stop condition. In read mode, the master device overrides the acknowledge bit by pulling the data line high during the low period before the ninth clock pulse; this is known as No Acknowledge. The master takes the data line low during the low period before the tenth clock pulse, and then high during the tenth clock pulse to assert a stop condition.

Any number of bytes of data can be transferred over the serial bus in one operation, but it is not possible to mix read and write in one operation because the type of operation is determined at the beginning and cannot subsequently be changed without starting a new operation.

In the NCP81022, write operations contain one, two or three bytes, and read operations contain one or two bytes. The command code or register address determines the number of bytes to be read or written, See the register map for more information.

To write data to one of the device data registers or read data from it, the address pointer register must be set so that the correct data register is addressed (i.e. command code), and then data can be written to that register or read from it.

The first byte of a read or write operation always contains an address that is stored in the address pointer register. If data is to be written to the device, the write operation contains a second data byte that is written to the register selected by the address pointer register.

This write byte operation is shown in Figure 22. The device address is sent over the bus, and then R/\overline{W} is set to 0. This is followed by two data bytes. The first data byte is the address of the internal data register to be written to, which is stored in the address pointer register. The second data byte is the data to be written to the internal data register.

2. The read byte operation is shown in Figure 23. First the command code needs to be written to the NCP81022 so that the required data is sent back. This is done by performing a write to the NCP81022 as before, but only the data byte containing the register address is sent, because no data is written to the register. A repeated start is then issued and a read operation is then performed consisting of the serial bus address; R/\overline{W} bit set to 1, followed by the data byte read from the data register.
3. It is not possible to read or write a data byte from a data register without first writing to the address pointer register, even if the address pointer register is already at the correct value.
4. In addition to supporting the send byte, the NCP81022 also supports the read byte, write byte, read word and write word protocols.

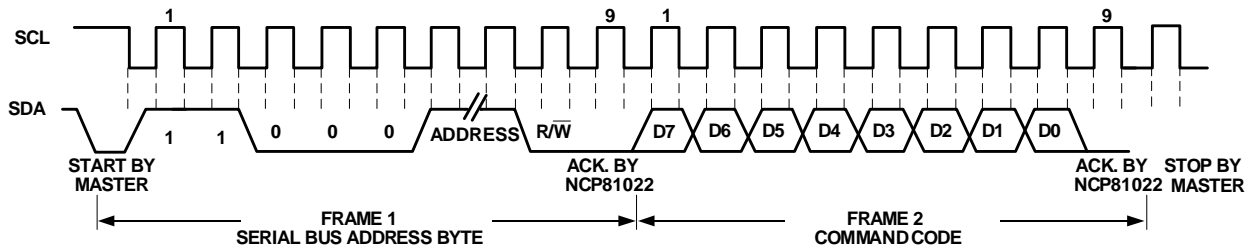

Figure 21. Send Byte

NCP81022

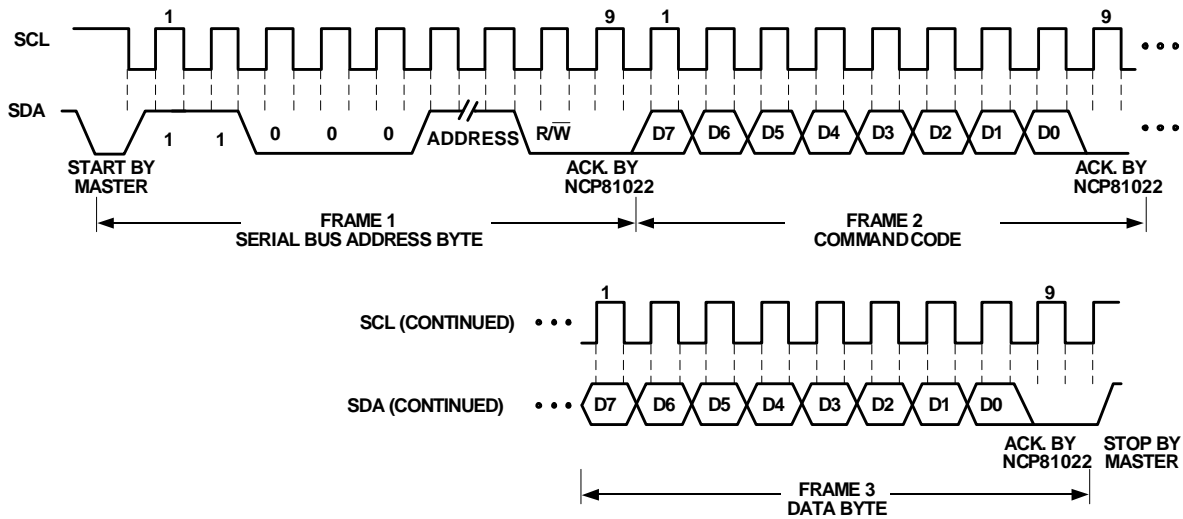

Figure 22. Write Byte

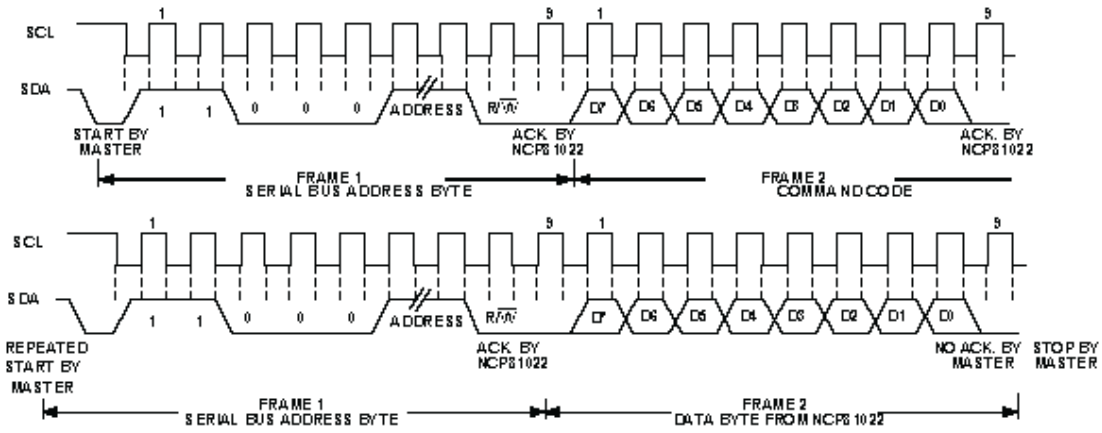

Figure 23. Read Byte

The following abbreviations are used in the diagrams:

- S – START
- P – STOP
- R – READ
- W – WRITE
- A – ACKNOWLEDGE
- \bar{A} – NO ACKNOWLEDGE

The NCP81022 uses the following write protocols.

Send Byte

In this operation, the master device sends a single command byte to a slave device as follows:

1. The master device asserts a start condition on SDA.
2. The master sends the 7-bit slave address followed by the write bit (low).
3. The addressed slave device asserts ACK on SDA.
4. The master sends a command code.
5. The slave asserts ACK on SDA.
6. The master asserts a stop condition on SDA and the transaction ends.

For the NCP81022, the send byte protocol is used to clear Faults. This operation is shown in Figure 22.

NCP81022

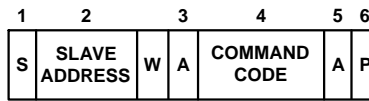

If the master is required to read data from the register immediately after setting up the address, it can assert a repeat start condition immediately after the final ACK and carry out a single byte read without asserting an intermediate stop condition.

Write Byte

In this operation, the master device sends a command byte and one data byte to the slave device as follows:

1. The master device asserts a start condition on SDA.
2. The master sends the 7-bit slave address followed by the write bit (low).
3. The addressed slave device asserts ACK on SDA.
4. The master sends a command code.
5. The slave asserts ACK on SDA.
6. The master sends a data byte.
7. The slave asserts ACK on SDA.
8. The master asserts a stop condition on SDA and the transaction ends.

The byte write operation is shown in Figure 22.

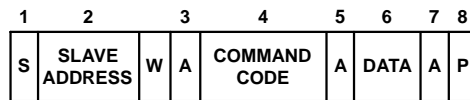

Write Word

In this operation, the master device sends a command byte and two data bytes to the slave device as follows:

1. The master device asserts a start condition on SDA.
2. The master sends the 7-bit slave address followed by the write bit (low).
3. The addressed slave device asserts ACK on SDA.
4. The master sends a command code.
5. The slave asserts ACK on SDA.
6. The master sends the first data byte.
7. The slave asserts ACK on SDA.
8. The master sends the second data byte.
9. The slave asserts ACK on SDA.
10. The master asserts a stop condition on SDA and the transaction ends.

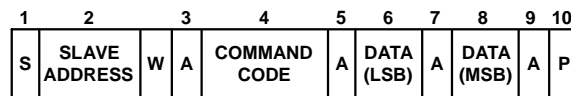

Block Write

In this operation, the master device sends a command byte and a byte count followed by the stated number of data bytes to the slave device as follows:

1. The master device asserts a START condition on SDA.
2. The master sends the 7-bit slave address followed by the write bit (low).
3. The addressed slave device asserts ACK on SDA.
4. The master sends a command code
5. The slave asserts ACK on SDA
6. The master sends the byte count N
7. The slave asserts ACK on SDA
8. The master sends the first data byte
9. The slave asserts ACK on SDA
10. The master sends the second data byte.
11. The slave asserts ACK on SDA
12. The master sends the remainder of the data bytes

NCP81022

13. The slave asserts an ACK on SDA after each data byte.
14. After the last data byte the master asserts a STOP condition on SDA

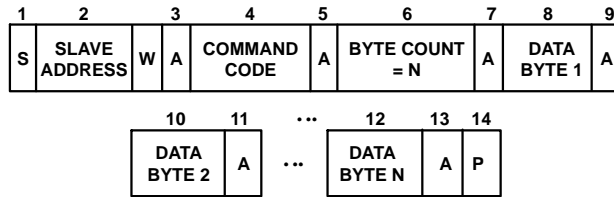

Extended Write Command

An extended write command is executed with the following format:

1. The master device asserts a START condition on SDA
2. The master sends the 7-bit slave address followed by the write bit (low).
3. The addressed slave device asserts ACK on SDA
4. The master sends a command extension code (FEh)
5. The slave asserted ACK on SDA
6. The master sends a command code
7. The slave asserted ACK on SDA
8. The master sends a data byte.
9. The slave asserts ACK on SDA.
10. The master asserts a stop condition on SDA and the transaction ends.

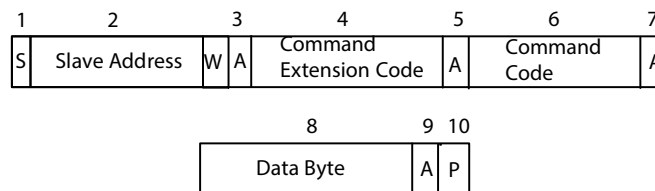

The NCP81022 uses the following SMBus read protocols.

Read Byte

In this operation, the master device receives a single byte from a slave device as follows:

1. The master device asserts a start condition on SDA.
2. The master sends the 7-bit slave address followed by the write bit (low).
3. The addressed slave device asserts ACK on SDA.
4. The master sends a command code.
5. The slave asserted ACK on SDA.
6. The master sends a repeated start condition on SDA
7. The master sends the 7 bit slave address followed by the read bit (high)
8. The slave asserts ACK on SDA
9. The slave sends the Data Byte
10. The master asserts NO ACK on SDA.
11. The master asserts a stop condition on SDA and the transaction ends.

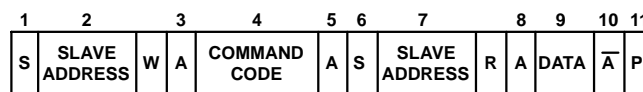

Read Word

In this operation, the master device receives two data bytes from a slave device as follows:

1. The master device asserts a start condition on SDA.
2. The master sends the 7-bit slave address followed by the write bit (low).

NCP81022

3. The addressed slave device asserts ACK on SDA.
4. The master sends a command code.
5. The slave asserted ACK on SDA.
6. The master sends a repeated start condition on SDA
7. The master sends the 7 bit slave address followed by the read bit (high)
8. The slave asserts ACK on SDA
9. The slave sends the first Data Byte (low Data Byte)
10. The master asserts ACK on SDA.
11. The slave sends the second Data Byte (high Data Byte)
12. The masters asserts a No ACK on SDA
13. The master asserts a stop condition on SDA and the transaction ends

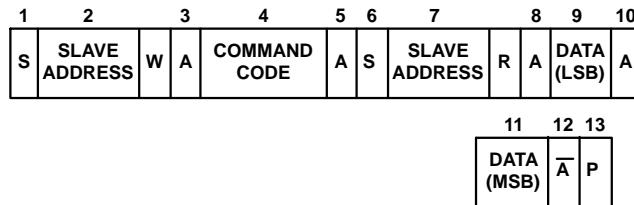

Block Read

In this operation, the master device sends a command byte, the slave sends a byte count followed by the stated number of data bytes to the master device as follows:

1. The master device asserts a START condition on SDA.
2. The master sends the 7-bit slave address followed by the write bit (low).
3. The addressed slave device asserts ACK on SDA.
4. The master sends a REPEATED START condition on SDA
5. The master sends the 7-bit slave address followed by the read bit (high).
6. The slave asserts ACK on SDA
7. The slave sends the byte count N
8. The master asserts ACK on SDA
9. The slave sends the first data byte
10. The master asserts ACK on SDA
11. The slave sends the remainder of the data bytes, the master asserts an ACK on SDA after each data byte.
12. After the last data byte the master asserts a No ACK on SDA.
13. The master asserts a STOP condition on SDA

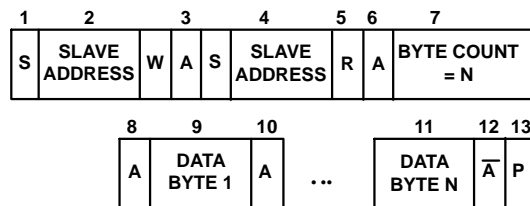

Extended Read Command

An extended Read byte command is executed with the following format and is shown in figure TBD below:

1. The master device asserts a START condition on SDA.
2. The master sends the 7-bit slave address followed by the write bit (low).
3. The addressed slave device asserts ACK on SDA
4. The master sends a command extension code (FEh)
5. The slave asserted ACK on SDA.
6. The master sends a command code
7. The slave asserted ACK on SDA.
8. The master sends a REPEATED START condition on SDA
9. The master sends the 7 bit slave address followed by the read bit (high)

NCP81022

10. The slave asserts ACK on SDA
11. The slave sends the Data Byte
12. The master asserts NO ACK on SDA.
13. The master asserts a stop condition on SDA and the transaction ends.

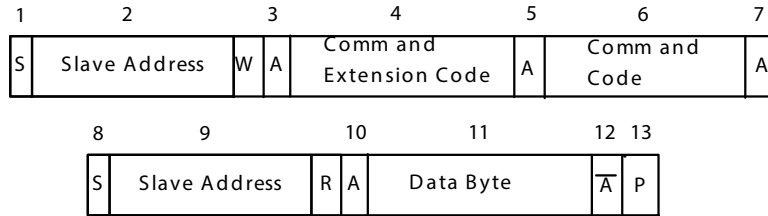

The NCP81022 includes a timeout feature. If there is no Bus activity for 35 ms, the NCP81022 assumes that the bus is locked and releases the bus. This prevents the device from locking or holding the SMBus expecting data. Some SMBus controllers cannot handle the SMBus timeout feature, so it can be disabled.

To prevent rogue programs or viruses from accessing critical NCP81022 register settings, the lock bit can be set. Setting Bit 0 of the Lock/Reset sets the lock bit and locks critical registers. In this mode, certain registers can no longer be written to until the NCP81022 is powered down and powered up again. For more information on which registers are locked see the register map.

REGISTER MAP

CMD Code	R/W	Default	Description	#Bytes	Comment		
0x01	R/W	0x80	Operation	1	00xx xxxx – Immediate Off 01xx xxxx – Soft Off 1000 xxxx – On (slew rate set by soft start) – Default 1001 10xx – Margin Low (Act on Fault) 1010 10xx – Margin High (Act on Fault)		
0x02	R/W	0x17	ON_OFF_Config	1	Configures how the controller is turned on and off		
					Bit	Default	Comment
					7:6	00	Reserved for Future Use
					5	1	Reserved
					4	1	This bit is read only. Switching starts when commanded by the Control Pin and the Operation Command, as set in Bits 3:0
					3	0	0 : Unit ignores OPERATION commands over the Interface 1: Unit responds to OPERATION command, power up may also depend upon Control input, as described in Bit 2
					2	1	0: Unit ignores Main Rail EN pin 1: Unit responds Main Rail EN pin, power up may also depend upon the Operation Register, as described for Bit 3
					1	1	Control Pin polarity 0 = Active Low 1 = Active High
0	1	This bit is read only. 1 means that when the controller is disabled it will either immediately turn off or soft off (as set in the Operation Command)					
0x03	W	NA	Clear_Faults	0	Writing any value to this command code will clear all Status Bits immediately.		
0x10	R/W	0x00	Write_Protect	1	The Write_protect command is used to control writing to the device. There is also a lock bit in the Manufacturer Specification Registers that once set will disable writes to all commands until the power to the NCP81022 is cycled.		
0x19	R	0xB0	Capability	1	This command allows the host to get some information on the SMBus device		
					Bit	Default	Comment
					7	1	PEC (Packet Error Checking is supported)
					6:5	01	Max supported bus speed is 400kHz
					4	0	Reserved
3:0	000	Reserved for future use					
0x20	R	0x22	Vout_Mode	1	The NCP81022 supports SVI2 VID mode for programming the output voltage		

NCP81022

REGISTER MAP

CMD Code	R/W	Default	Description	#Bytes	Comment			
0x21	R/W	0x00	Vout_Command	2	Sets the output voltage using the SVI2 VID table decoding			
0x24	R/W	0x00	Vout_Max	2	Sets the max output voltage when programming VID Code through SMBus. When programming VID through SVI2, then SVI2 Vout max applies.			
0x25	R/W	0x0018	VOUT_MARGIN_HIGH	2	Sets the output voltage when operation command is set to Margin High. Programmed in VID Mode.			
0x26	R/W	0x00A8	VOUT_MARGIN_LOW	2	Sets the output voltage when operation command is set to Margin Low. Programmed in VID Mode.			
0x38	R/W	0x0001	IOUT_CAL_GAIN	2	Sets the ratio of voltage sensed to current output. Scale is Linear and is expressed in 1/Ω			
0x39	R/W	0x0000	Iout Offset					
0x4A	R/W		Iout_Fault_limit		This sets the output current fault limit. Once exceeded Bit 7 of the Status IOUT Command gets set and the FAULT output gets asserted (if not masked)			
0x55	R/W	0x0010	VIN_OV_FAULT_LIMIT	2	This sets the input over voltage fault limit. Once exceeded the VIN Overvoltage Fault Bit, Bit 7, gets set in the Status Input Register and the FAULT output is asserted. This limit is set using Linear Mode, in V.			
0x68	R/W	0x012C	POUT_OP_FAULT_LIMIT	2	This sets the output power over power fault limit. Once exceeded Bit 1 of the Status IOUT Command gets set and the FAULT output gets asserted (if not masked)			
0x78	R	0x00	STATUS BYTE	1	Bit	Name	Description	
					7	BUSY	A fault was declared because the NCP81022 was busy and unable to respond	
					6	OFF	This bit is set whenever the NCP81022 is not switching	
					5	VOUT_OV	This bit gets set whenever the NCP81022 goes into OVP mode.	
					4	IOUT_OC	This bit gets set whenever the NCP81022 latches off due to an over current event.	
					3	Reserved	Reserved	
					2	Reserved	Reserved	
					1	Reserved	Reserved	
					0	None of the Above	A fault has occurred which is not one of the above	
0x79	R	0x0000	STATUS WORD	2	Byte	Bit	Name	Description
					Low	7	Res	Reserved for future use
					Low	6	OFF	This bit is set whenever the NCP81022 is not switching
					Low	5	VOUT_OV	This bit gets set whenever the NCP81022 goes into OVP mode
					Low	4	IOUT_OC	This bit gets set whenever the NCP81022 latches off due to an over current event
					Low	3	Reserved	Reserved
					Low	2	Reserved	Reserved
					Low	1	Reserved	Reserved
					Low	0	None of the Above	A fault has occurred which is not one of the above
					Byte	Bit	Name	Description
					High	7	VOUT	This bit gets set whenever the measured output voltage goes outside its power good limits or an OVP event has taken place, i.e. any bit in Status VOUT is set
					High	6	Iout/Pout	This bit gets set whenever the measured output current or power exceeds its warning limit or goes into OCP. i.e. any bit in Status IOUT is set
					High	5	Input	This bit gets set whenever the measured input voltage falls outside its Fault limit
					High	4	MFR	A manufacturer specific warning or fault has occurred
					High	3	VDD_PWRGD	The VDD_PWRGD signal is deasserted. Same as PowerGood in General Status
					High	2	Reserved	Reserved
					High	1	OTHER	A Status bit in Status Other is asserted
					High	0	Res	Reserved for future use

NCP81022

REGISTER MAP

CMD Code	R/W	Default	Description	#Bytes	Comment		
					Bit	Name	Description
0x7A	R	0x00	STATUS VOUT	1			
					7	VOUT_OVERVOLTAGE FAULT	This bit gets set whenever an OVP Event takes place
					6	VOUT_OVERVOLTAGE WARNING	Not Supported
					5	VOUT_UNDERVOLTAGE WARNING	Not supported
					4	Reserved	Reserved
					3	VOUT_MAX Warning	Not supported, Can't program an output greater than max VID as there are no bits to program it
					2	Reserved	Reserved
					1	Reserved	Reserved
					0	Reserved	Reserved
0x7B	R	0x00	STATUS IOOUT	1			
					7	IOOUT Overcurrent Fault	This bit gets set if the NCP81022 latches off due to an OCP Event
					6	Reserved	Reserved for future use
					5	IOOUT Overcurrent Warning	Not supported
					4	Reserved	Reserved for future use
					3	Reserved	Reserved for future use
					2	Reserved	Reserved for future use
					1	POUT Over Power Fault	This bit gets set if the measured POUT exceeds the FAULT Limit
					0	Reserved	Reserved
0x7C	R	0x00	STATUS INPUT	1			
					7	VIN Overvoltage FAULT	This bit gets set when the input voltage goes above its programmed FAULT limit
					6	Reserved	Reserved for future use.
					5	Reserved	Reserved for future use.
					4	Reserved	Reserved for future use.
					3	Reserved	Reserved for future use.
					2	Reserved	Reserved for future use.
					1	Reserved	Reserved for future use.
					0	Reserved	Reserved for future use.
0x88	R	0x00	Read_VIN	2	Readback of input voltage, measured using VRMP Input. Readback is in linear mode		
0x8B	R	0x00	Read_VOUT	2	Readback output voltage. Voltage is read back in VID Mode		
0x8C	R	0x00	Read_IOOUT	2	Readback output current. Current is read back in Linear Mode (Amps)		
0x96	R	0x00	Read_POUT	2	Readback Output Power, read back in Linear Mode in W's.		
0x99	R	0x1A	MFR_ID	2	0x1A		
0x9A	R	0x1022	MFR_MODEL	2	0x1022		
0x9B	R	0x00	MFR_REVISION	1	0x00		
0xD0	R/W	0x00	Lock/Reset	1	Bit 0 = Lock Bit Bit 1 = Reset Bit		
0xD1	R/W	0x01	Manufacturer Config	1	Bit 0 = ADC Bit 1 = Reserved Bit 2 = Reserved Bit 3 = SMB_TO_EN		

NCP81022

REGISTER MAP

CMD Code	R/W	Default	Description	#Bytes	Comment				
0xD2	R/W	0x00	VR Config 1	1	Bit 0= 0, All SVI2 parameters programmed through SVI2; Default = 0 1, All SVI2 parameters programmed through Digital interface Bit 1 = Reserved Bit 2 = Voltage rail; Voltage rail = 0 then main rail is programmable, Voltage rail = 1 then North Bridge rail is programmable over SMBus. Default = 0 Bit 3 = Reserved Bit 4 = Reserved Bit 5 = Reserved Bit 6 = CLIM_EN, 0 = CLIM Latch off enabled = default, 1 = CLIM Latchoff disabled Bit 7 = Reserved				
0xD3	R/W	0x03	VR Config 2	1	Comment				
					Bit	Name	PSI0#	PSI1#	Phase
					0:1	PSI0/PSI1	0	0	1-Phase DCM
							0	1	1-Phase CCM
							1	0	Full Phase
							1	1	Full Phase
					2	Not Supported			
3:4	Reserved								
5	Not Supported								
6	Reserved								
0xD4	R		Vout_Linear	2	Readback of output voltage in Linear Mode. Exponent fixed at -9				
0xD5	R/W	0x02	Vout Trim	1	Programmable Offset Voltage. Data format is 2's complement 00 = 0 01-25 mV 10 = initial programmed offset (default) 11 = +25 mV 11				
0xD7	R/W	0x00	Initial offset						
0xE3	R/W	0x08	Current Limit	1	Sets the value of the current limit relative to the current limit set by the ILIM pin.				
0xE4	R/W	0x03	Loadline	1	This register sets the internal loadline attenuation. The max loadline is controlled externally by setting the gain of the CSA. The max loadline can be adjusted between 0% and 100% of the external loadline. 000-Remove all loadline drop from output 001-LL slope 12.9% 010-LL slope 25.8% 011-LL slope 38.7% 100- LL slope 51.6% 101- LL slope 64.8% 110 LL slope 77.4% 111 LL slope 90.3%				
0xE5	R/W	0x03	Initial loadline						
0xE6	R/W	0x00	Special purpose offset						
0xE7	R	0x00	Current VID	2	This register reports back the current VID Code being output incl. Offset being output				
0xF3	R	0x00	Vboot	1	Read back Vboot value- VID code format				
0xF7	R/W	0x0A	OSC Freq.	1	This register adjusts the oscillator frequency from 240Khz to 1 MHz				
0xFB	R/W	0x00	General Status		Bit 0 - Ready Bit 1 - VDD_PWRGD Bit 3 - RESERVED Bit 4 - RESERVED Bit 5 - Clim limit exceeded but not long enough for Latch off				
0xFC	R	0x00	Reserved		Reserved				
0xFD	R	0x00	Phase Status		Bit 0 = Phase 1 Bit 1 = Phase 2 Bit 2 = Phase 3 Bit 3 = Phase 4				

NCP81022

ORDERING INFORMATION

Device	Package	Shipping†
NCP81022MNTXG	QFN52 (Pb-Free)	2500 / Tape & Reel

†For information on tape and reel specifications, including part orientation and tape sizes, please refer to our Tape and Reel Packaging Specifications Brochure, BRD8011/D.

NCP81022

PACKAGE DIMENSIONS

QFN52 6x6, 0.4P CASE 485BE ISSUE B

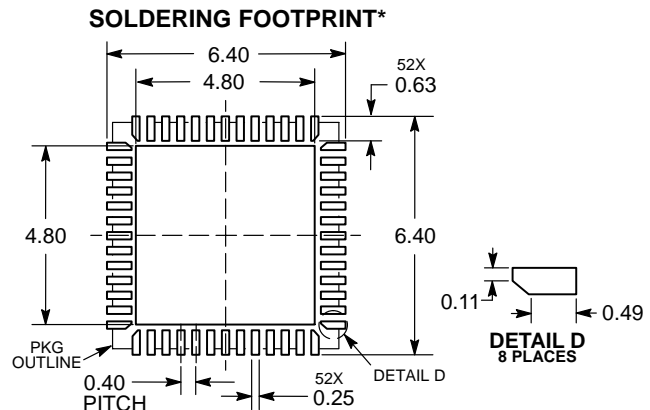
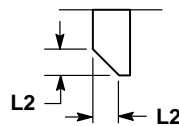
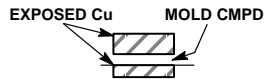
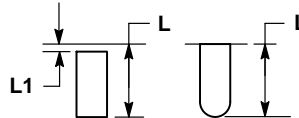
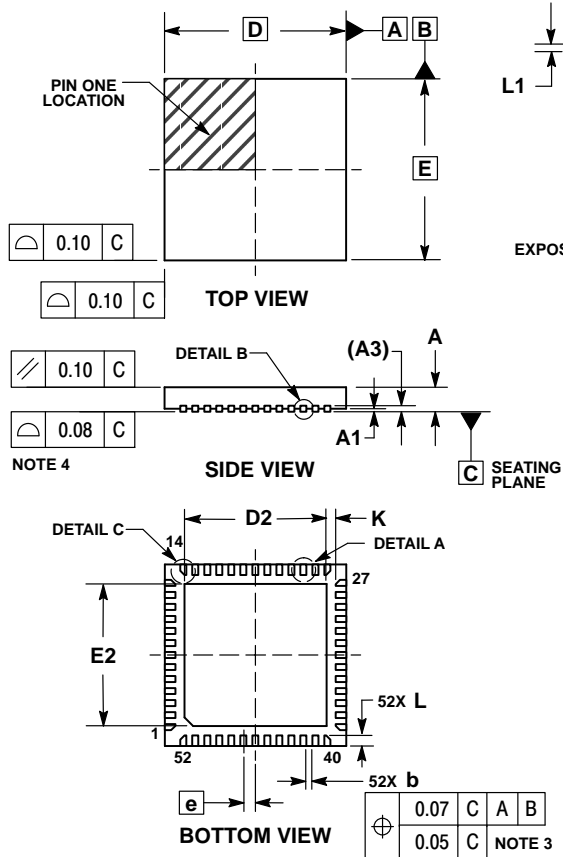

DIMENSIONS: MILLIMETERS

*For additional information on our Pb-Free strategy and soldering details, please download the ON Semiconductor Soldering and Mounting Techniques Reference Manual, SOLDERRM/D.

NOTES:

1. DIMENSIONING AND TOLERANCING PER ASME Y14.5M, 1994.
2. CONTROLLING DIMENSIONS: MILLIMETERS.
3. DIMENSION b APPLIES TO PLATED TERMINAL AND IS MEASURED BETWEEN 0.15 AND 0.30mm FROM TERMINAL TIP
4. COPLANARITY APPLIES TO THE EXPOSED PAD AS WELL AS THE TERMINALS.

DIM	MILLIMETERS	
	MIN	MAX
A	0.80	1.00
A1	0.00	0.05
A3	0.20	REF
b	0.15	0.25
D	6.00	BSC
D2	4.60	4.80
E	6.00	BSC
E2	4.60	4.80
e	0.40	BSC
K	0.30	REF
L	0.25	0.45
L1	0.00	0.15
L2	0.15	REF

AMD is a registered trademark of Advanced Micro Devices, Inc.

ON Semiconductor and the are registered trademarks of Semiconductor Components Industries, LLC (SCILLC) or its subsidiaries in the United States and/or other countries. SCILLC owns the rights to a number of patents, trademarks, copyrights, trade secrets, and other intellectual property. A listing of SCILLC's product/patent coverage may be accessed at www.onsemi.com/site/pdf/Patent-Marking.pdf. SCILLC reserves the right to make changes without further notice to any products herein. SCILLC makes no warranty, representation or guarantee regarding the suitability of its products for any particular purpose, nor does SCILLC assume any liability arising out of the application or use of any product or circuit, and specifically disclaims any and all liability, including without limitation special, consequential or incidental damages. "Typical" parameters which may be provided in SCILLC data sheets and/or specifications can and do vary in different applications and actual performance may vary over time. All operating parameters, including "Typicals" must be validated for each customer application by customer's technical experts. SCILLC does not convey any license under its patent rights nor the rights of others. SCILLC products are not designed, intended, or authorized for use as components in systems intended for surgical implant into the body, or other applications intended to support or sustain life, or for any other application in which the failure of the SCILLC product could create a situation where personal injury or death may occur. Should Buyer purchase or use SCILLC products for any such unintended or unauthorized application, Buyer shall indemnify and hold SCILLC and its officers, employees, subsidiaries, affiliates, and distributors harmless against all claims, costs, damages, and expenses, and reasonable attorney fees arising out of, directly or indirectly, any claim of personal injury or death associated with such unintended or unauthorized use, even if such claim alleges that SCILLC was negligent regarding the design or manufacture of the part. SCILLC is an Equal Opportunity/Affirmative Action Employer. This literature is subject to all applicable copyright laws and is not for resale in any manner.

PUBLICATION ORDERING INFORMATION

LITERATURE FULFILLMENT:
Literature Distribution Center for ON Semiconductor
19521 E. 32nd Pkwy, Aurora, Colorado 80011 USA
Phone: 303-675-2175 or 800-344-3860 Toll Free USA/Canada
Fax: 303-675-2176 or 800-344-3867 Toll Free USA/Canada
Email: orderlit@onsemi.com

N. American Technical Support: 800-282-9855 Toll Free
USA/Canada
Europe, Middle East and Africa Technical Support:
Phone: 421 33 790 2910
Japan Customer Focus Center
Phone: 81-3-5817-1050

ON Semiconductor Website: www.onsemi.com
Order Literature: <http://www.onsemi.com/orderlit>
For additional information, please contact your local Sales Representative