

## 阅读申明

- 1.本站收集的数据手册和产品资料都来自互联网，版权归原作者所有。如读者和版权方有任何异议请及时告之，我们将妥善解决。
- 2.本站提供的中文数据手册是英文数据手册的中文翻译，其目的是协助用户阅读，该译文无法自动跟随原稿更新，同时也可能存在翻译上的不当。建议读者以英文原稿为参考以便获得更精准的信息。
- 3.本站提供的产品资料，来自厂商的技术支持或者使用者的心得体会等，其内容可能存在描述上的差异，建议读者做出适当判断。
- 4.如需与我们联系，请发邮件到marketing@iczoom.com，主题请标有“数据手册”字样。

## Read Statement

1. The datasheets and other product information on the site are all from network reference or other public materials, and the copyright belongs to the original author and original published source. If readers and copyright owners have any objections, please contact us and we will deal with it in a timely manner.
2. The Chinese datasheets provided on the website is a Chinese translation of the English datasheets. Its purpose is for reader's learning exchange only and do not involve commercial purposes. The translation cannot be automatically updated with the original manuscript, and there may also be improper translations. Readers are advised to use the English manuscript as a reference for more accurate information.
3. All product information provided on the website refer to solutions from manufacturers' technical support or users the contents may have differences in description, and readers are advised to take the original article as the standard.
4. If you have any questions, please contact us at marketing@iczoom.com and mark the subject with "Datasheets" .

STRUCTURE Silicon Monolithic Integrated Circuit

NAME OF PRODUCT DC-AC Inverter Control IC

 TYPE **BD9215AFV**

 FUNCTION
 

- 36V High voltage process
- 1ch control with Full-Bridge
- Lamp current and voltage sense feed back control
- Sequencing easily achieved with Soft Start Control
- Short circuit protection with Timer Latch
- Under Voltage Lock Out
- Mode-selectable the operating or stand-by mode by stand-by pin
- For master IC, Synchronous operating with slave IC
- BURST mode controlled by PWM and DC input
- Output liner Control by external DC voltage

## ○Absolute Maximum Ratings (Ta = 25°C)

Parameter	Symbol	Limits	Unit
Supply Voltage	Vcc	36	V
BST pin	BST	40	V
SW pin	SW	36	V
BST-SW voltage difference	BST-SW	15	V
Operating Temperature Range	Topr	-40~+85	°C
Storage Temperature Range	Tstg	-55~+150	°C
Maximum Junction Temperature	Tjmax	+150	°C
Power Dissipation	Pd	1062*	mW

\*Pd derate at 8.5mW/°C for temperature above Ta = 25°C (When mounted on a PCB 70.0mm × 70.0mm × 1.6mm)

## ○Operating condition

Parameter	Symbol	Limits	Unit
Supply voltage	Vcc	8.5~30.0	V
BST voltage	BST	5.0~37.5	V
BST-SW voltage difference	BST-SW	5.0~14.0	V
DRIVER frequency	FOUT	30~110	kHz
BCT oscillation frequency	fBCT	0.05~1.00	kHz

○Electric Characteristics (Ta=25°C、VCC=24V、STB=UVLO=3.0V)

Parameter	Symbol	Limits			Unit	Conditions
		MIN.	TYP.	MAX.		
((WHOLE DEVICE))						
Operating current	Icc1	—	5.0	9.0	mA	FOUT=60kHz, FB=GND, BST=OPEN
Stand-by current	Icc2	—	6.3	20	μA	
((STAND BY CONTROL))						
Stand-by voltage H	VstH	2	—	VCC	V	System ON
Stand-by voltage L	VstL	-0.3	—	0.8	V	System OFF
((UVLO BLOCK))						
Operating voltage (UVLO)	Vuvlo	2.16	2.25	2.34	V	
Hysteresis width (UVLO)	$\Delta$ Vuvlo	0.085	0.110	0.135	V	
((REG BLOCK))						
REG output voltage	VREG	7.35	7.50	7.65	V	
REG source current	IREG	20	—	—	mA	
((OSC BLOCK))						
RT pin Voltage	VRT	1.05	1.50	1.95	V	
Soft start current	ISS	1.7	2.2	2.7	μA	
SS operation start Voltage	VSS_ST	0.18	0.20	0.22	V	
SS term END Voltage	VSS_ED	1.35	1.50	1.65	V	
SRT ON resistance	RSRT	—	85	170	Ω	
((BOSC BLOCK))						
BOSC Max voltage	VBCTH	1.94	2	2.06	V	fBCT=0.3kHz
BOSC Min voltage	VBCTL	0.4	0.5	0.6	V	fBCT=0.3kHz
BOSC constant current	IBCT	1.35/BRT	1.5/BRT	1.65/BRT	A	VBCT=0.2V
BOSC frequency	fBCT	291	300	309	Hz	(BRT=37.8kΩ BCT=0.047μF)
((FEED BACK BLOCK))						
IS threshold voltage 1	VIS1	1.225	1.25	1.275	V	
IS threshold voltage 2	VIS2	—	VREFIN	VIS1	V	VREF applying voltage
VS threshold voltage	VVS	1.22	1.25	1.28	V	
IS source current 1	IIS1	—	—	0.9	μA	DUTY=2.2V
IS source current 2	IIS2	40	50	60	μA	DUTY=0V IS=1.0V
VS source current	IVS	—	—	0.9	μA	
IS COMP detect voltage 1	VISCOMP1	0.606	0.625	0.644	V	VREFIN ≥ 1.25V
IS COMP detect voltage 2	VISCOMP2	—	0.50	—	V	VREFIN= 1V
VREF input voltage range	VREFIN	0.6	—	1.6	V	No effect at VREF > 1.25V
((DUTY BLOCK))						
High voltage	VDUTY-OUTH	3.8	4.0	4.2	V	
Low voltage	VDUTY-OUTL	—	—	0.5	V	
DUTY-OUT sink resistance	RDUTY-OUT_sink	—	150	300	Ω	
DUTY-OUT source resistance	RDUTY-OUT_source	—	300	600	Ω	
((OUTPUT BLOCK))						
LN output sink resistance	RsinkLN	1.8	3.5	7.0	Ω	
LN output source resistance	RsourceLN	4.5	9.0	18.0	Ω	
HN output sink resistance	RsinkHN	1.8	3.5	7.0	Ω	VBST-VSW=7.0V
HN output source resistance	RsourceLN	4.5	9.0	18.0	Ω	VBST-VSW=7.0V
MAX DUTY	MAX DUTY	46.0	48.5	49.5	%	FOUT=60kHz
OFF period	TOFF	100	200	400	ns	
Drive output frequency	FOUT	57.9	60	62.1	kHz	RT=21kΩ
((TIMER LATCH BLOCK))						
Timer Latch setting voltage	VCP	3.88	4.0	4.12	V	
Timer Latch setting current	ICP	1.6	2.1	2.6	μA	
((COMP BLOCK))						
COMP over voltage detect voltage	VCOMPH	3.88	4.0	4.12	V	VSS > 1.65V
Hysteresis width (COMP)	$\Delta$ VCOMPH	0.15	0.20	0.25	V	
((Synchronous Block))						
High voltage	VCT_SYNC	3.8	4.0	4.2	V	
Low voltage	VCT_SYNC	—	—	0.5	V	
CT_SYNC_OUT sink resistance	RSYNC_OUT_sink	—	150	300	Ω	
CT_SYNC_OUT source resistance	RSYNC_OUT_source	—	300	400	Ω	

(This product is not designed to be radiation-resistant.)

○Package Dimensions

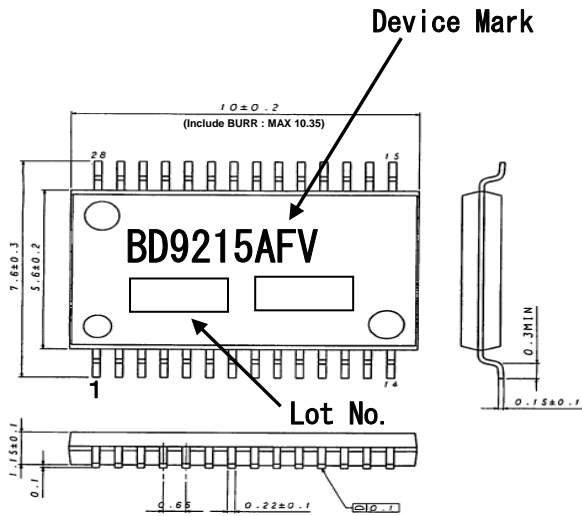

SSOP-B28 (Unit:mm)

○Block Diagram

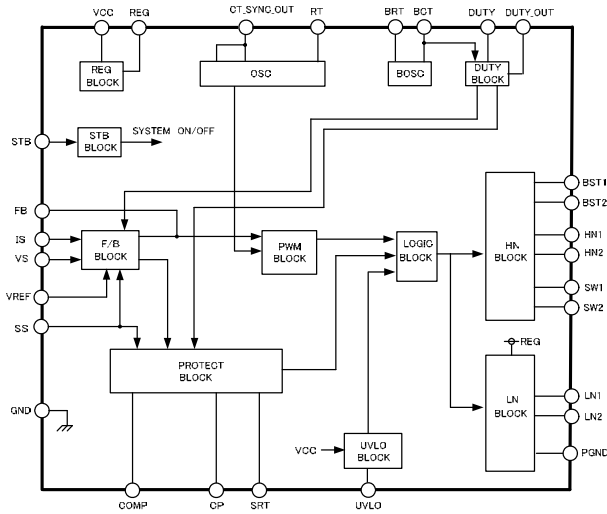

○Pin Description

PIN No.	PIN NAME	FUNCTION
1	PGND	Ground for FET drivers
2	LN2	NMOS FET driver
3	HN2	NMOS FET driver
4	SW2	Lower rail voltage for HN2 output
5	BST2	Boot-Strap input for HN2 output
6	DUTY_OUT	BURST signal output pin
7	CT_SYNC_OUT	CT synchronous signal output pin
8	SRT	External resistor from SRT to RT for adjusting the start-up triangle oscillator
9	RT	External resistor from RT to GND for adjusting the triangle oscillator
10	GND	GROUND
11	BCT	External capacitor from BCT to GND for adjusting the BURST triangle oscillator
12	BRT	External resistor from BRT to GND for adjusting the BURST triangle oscillator
13	DUTY	Control PWM mode and BURST mode
14	STB	Stand-by switch
15	CP	External capacitor from CP to GND for Timer Latch
16	VREF	Reference voltage input pin for Error amplifier
17	VS	Error amplifier input
18	IS	Error amplifier input
19	FB	Error amplifier output
20	SS	External capacitor from SS to GND for Soft Start Control
21	COMP	Over voltage detect pin
22	VCC	Supply voltage input
23	UVLO	External Under Voltage Lock Out
24	REG	Internal regulator output
25	BST1	Boot-Strap input for HN1 output
26	SW1	Lower rail voltage for HN1 output
27	HN1	NMOS FET driver
28	LN1	NMOS FET driver

○NOTE FOR USE

1. This product is produced with strict quality control, but might be destroyed if used beyond its absolute maximum ratings. Once IC is destroyed, failure mode will be difficult to determine, like short mode or open mode. Therefore, physical protection countermeasure, like fuse is recommended in case operating conditions go beyond the expected absolute maximum ratings.
2. The circuit functionality is guaranteed within of ambient temperature operation range as long as it is within recommended operating range. The standard electrical characteristic values cannot be guaranteed at other voltages in the operating ranges, however the variation will be small.
3. Mounting failures, such as misdirection or miscounts, may harm the device.
4. A strong electromagnetic field may cause the IC to malfunction.
5. The GND pin should be the location within  $\pm 0.3V$  compared with the PGND pin. ALL Pin (except SW1, SW2, BST1, BST2, HN1, HN2,) Voltage should be under VCC voltage +0.3V even if the voltage is under each terminal ratings.
6. BD9215AFV incorporate a built-in thermal shutdown circuit (TSD circuit). The thermal shutdown circuit (TSD circuit) is designed only to shut the IC off to prevent runaway thermal operation. It is not designed to protect the IC or guarantee its operation of the thermal shutdown circuit is assumed.
7. When modifying the external circuit components, make sure to leave an adequate margin for external components actual value and tolerance as well as dispersion of the IC.
8. About the external FET, the parasitic Capacitor may cause the gate voltage to change, when the drain voltage is switching. Make sure to leave adequate margin for this IC variation.
9. Under operating CP charge (under error mode) analog dimming and burst dimming are not operate.
10. Under operating Slow Start Control (SS is less than 1.5V), It does not operate Timer Latch.
11. By STB voltage, BD9215AFV are changed to 2 states. Therefore, do not input STB pin voltage between one state and the other state (0.8~2.0V).
12. The pin connected a connector need to connect to the resistor for electrical surge destruction.
13. This IC is a monolithic IC which (as shown is Fig-1) has P<sup>+</sup> substrate and between the various pins. A P-N junction is formed from this P layer of each pin. For example, the relation between each potential is as follows,

○(When GND > PinB and GND > PinA, the P-N junction operates as a parasitic diode.)

○(When PinB > GND > PinA, the P-N junction operates as a parasitic transistor.)

Parasitic diodes can occur inevitably in the structure of the IC. The operation of parasitic diodes can result in mutual interference among circuits as well as operation faults and physical damage. Accordingly you must not use methods by which parasitic diodes operate, such as applying a voltage that is lower than the GND (P substrate) voltage to an input pin.

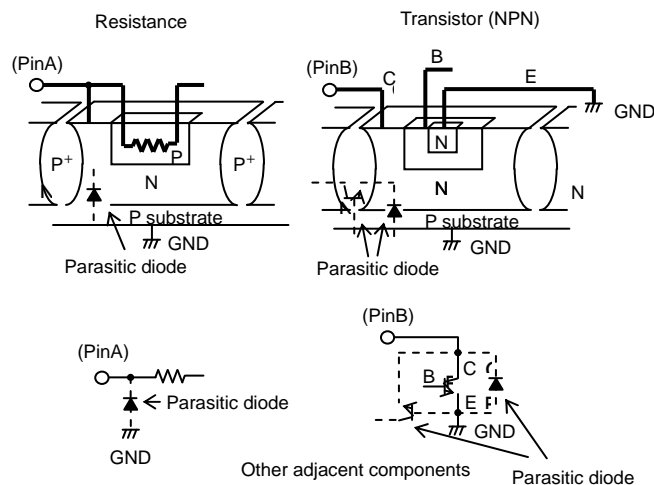

Fig-1 Simplified structure of a Bipolar IC

## Notes

No copying or reproduction of this document, in part or in whole, is permitted without the consent of ROHM Co.,Ltd.

The content specified herein is subject to change for improvement without notice.

The content specified herein is for the purpose of introducing ROHM's products (hereinafter "Products"). If you wish to use any such Product, please be sure to refer to the specifications, which can be obtained from ROHM upon request.

Examples of application circuits, circuit constants and any other information contained herein illustrate the standard usage and operations of the Products. The peripheral conditions must be taken into account when designing circuits for mass production.

Great care was taken in ensuring the accuracy of the information specified in this document. However, should you incur any damage arising from any inaccuracy or misprint of such information, ROHM shall bear no responsibility for such damage.

The technical information specified herein is intended only to show the typical functions of and examples of application circuits for the Products. ROHM does not grant you, explicitly or implicitly, any license to use or exercise intellectual property or other rights held by ROHM and other parties. ROHM shall bear no responsibility whatsoever for any dispute arising from the use of such technical information.

The Products specified in this document are intended to be used with general-use electronic equipment or devices (such as audio visual equipment, office-automation equipment, communication devices, electronic appliances and amusement devices).

The Products specified in this document are not designed to be radiation tolerant.

While ROHM always makes efforts to enhance the quality and reliability of its Products, a Product may fail or malfunction for a variety of reasons.

Please be sure to implement in your equipment using the Products safety measures to guard against the possibility of physical injury, fire or any other damage caused in the event of the failure of any Product, such as derating, redundancy, fire control and fail-safe designs. ROHM shall bear no responsibility whatsoever for your use of any Product outside of the prescribed scope or not in accordance with the instruction manual.

The Products are not designed or manufactured to be used with any equipment, device or system which requires an extremely high level of reliability the failure or malfunction of which may result in a direct threat to human life or create a risk of human injury (such as a medical instrument, transportation equipment, aerospace machinery, nuclear-reactor controller, fuel-controller or other safety device). ROHM shall bear no responsibility in any way for use of any of the Products for the above special purposes. If a Product is intended to be used for any such special purpose, please contact a ROHM sales representative before purchasing.

If you intend to export or ship overseas any Product or technology specified herein that may be controlled under the Foreign Exchange and the Foreign Trade Law, you will be required to obtain a license or permit under the Law.



Thank you for your accessing to ROHM product informations.  
More detail product informations and catalogs are available, please contact us.

## ROHM Customer Support System

<http://www.rohm.com/contact/>