

阅读申明

- 1.本站收集的数据手册和产品资料都来自互联网，版权归原作者所有。如读者和版权方有任何异议请及时告之，我们将妥善解决。
- 2.本站提供的中文数据手册是英文数据手册的中文翻译，其目的是协助用户阅读，该译文无法自动跟随原稿更新，同时也可能存在翻译上的不当。建议读者以英文原稿为参考以便获得更精准的信息。
- 3.本站提供的产品资料，来自厂商的技术支持或者使用者的心得体会等，其内容可能存在描述上的差异，建议读者做出适当判断。
- 4.如需与我们联系，请发邮件到marketing@iczoom.com，主题请标有“数据手册”字样。

Read Statement

1. The datasheets and other product information on the site are all from network reference or other public materials, and the copyright belongs to the original author and original published source. If readers and copyright owners have any objections, please contact us and we will deal with it in a timely manner.
2. The Chinese datasheets provided on the website is a Chinese translation of the English datasheets. Its purpose is for reader's learning exchange only and do not involve commercial purposes. The translation cannot be automatically updated with the original manuscript, and there may also be improper translations. Readers are advised to use the English manuscript as a reference for more accurate information.
3. All product information provided on the website refer to solutions from manufacturers' technical support or users the contents may have differences in description, and readers are advised to take the original article as the standard.
4. If you have any questions, please contact us at marketing@iczoom.com and mark the subject with "Datasheets" .

Features

- Digital Self-supervising Watchdog with Hysteresis
- Three 250-mA Output Drivers
- One Relay Driver, Two Lamp Drivers
- Lamp Drivers with Auxiliary Ground
- Lamp Drivers Short-circuit Protected
- Lamp Drivers with Status Feedback
- Enable Output
- Over-/Undervoltage Detection and Reset
- All Power Outputs Protected Against Standard Transients
- All Power Outputs Protected Against 40-V Load Dump
- Automatically Activated Lamp Drivers if V_S is Disconnected
- Automatically Activated Lamp Drivers Via AUX GND if Standard Ground is Disconnected

Description

The U6809B is designed to support the fail-safe function of safety-critical systems such as ABS. It includes a relay driver, two independent short-circuit-protected lamp drivers which are supplied by redundant ground lines, two monitoring circuits for the lamp driver output voltage and output current, a watchdog controlled by an external RC network and a reset circuit initiated by an over- and undervoltage condition of the 5-V supply providing a positive and a negative reset signal.



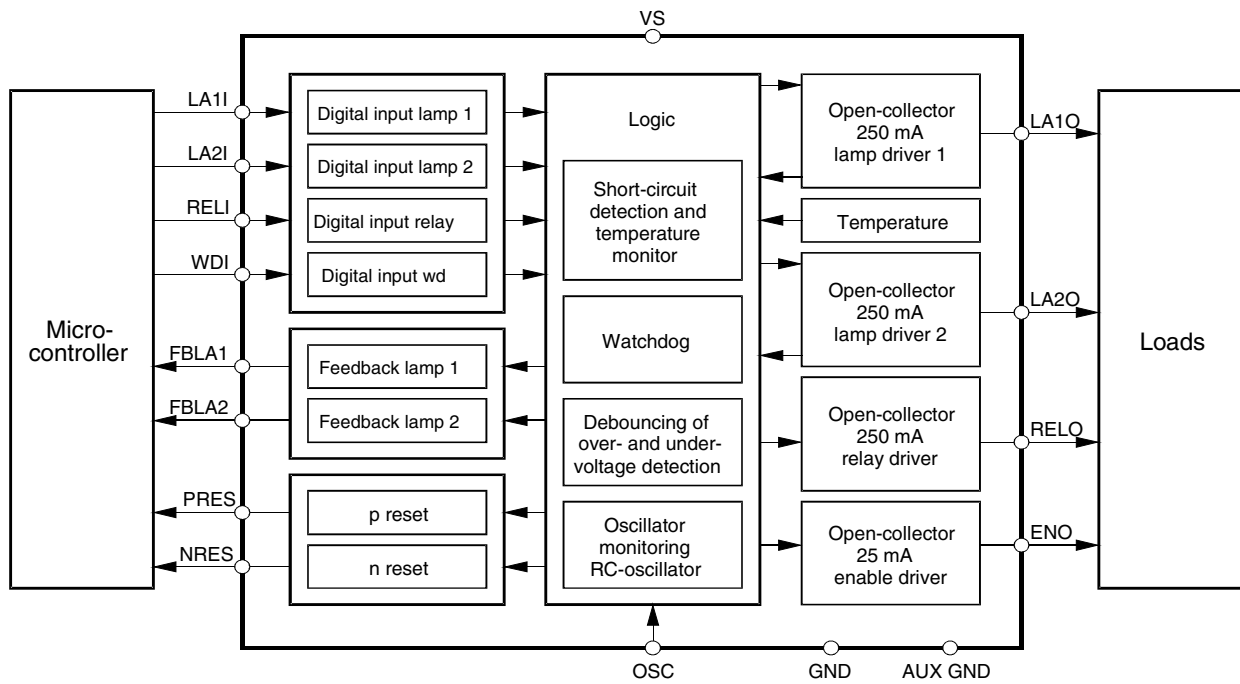
Fail-safe IC with Relay Driver and Lamp Driver

U6809B

Rev. 4764A-AUTO-10/03

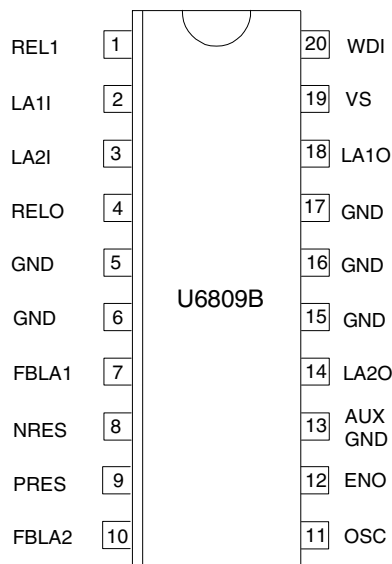


Figure 1. Block Diagram



Pin Configuration

Figure 2. Pinning SO20



Pin Description

Pin	Name	Type	Function	Logic
1	RELI	Digital input	Activation of relay driver	Driver on: L Driver off: H
2	LA1I	Digital input	Activation of lamp driver 1	Driver off: L Driver on: H
3	LA2I	Digital input	Activation of lamp driver 2	Driver off: L Driver on: H
4	RELO	Open-collector driver output	Fail-safe relay driver	Driver off: --- Driver on: L
5, 6	GND	Supply	Standard ground	
7	FBLA1	Digital output	Feedback lamp1	See Table 1 on page 5 and Table 2 on page 5
8	NRES	Digital output	Negative reset signal	Reset: L No reset: H
9	PRES	Digital output	Positive reset signal	Reset: H No reset: L
10	FBLA2	Digital output	Feedback lamp 2	See Table 1 on page 5 and Table 2 on page 5
11	OSC	Analog input	External RC for watchdog timer	
12	ENO	Open-collector output	Watchdog disable output	Watchdog ok: --- Watchdog n ok: L
13	AUX, GND	Supply	Auxiliary ground of lamp drivers	
14	LA2O	Open-collector driver output	Warning lamp driver	Driver off: --- Driver on: L
15, 16, 17	GND	Supply	Standard ground	
18	LA1O	Open-collector driver output	Warning lamp driver	Driver off: --- Driver on: L
19	VS	Supply	5 V supply	
20	WDI	Digital input	Watchdog trigger signal	Pulse sequence

Detailed Block Diagram with External Components

Figure 3. Detailed Block Diagram

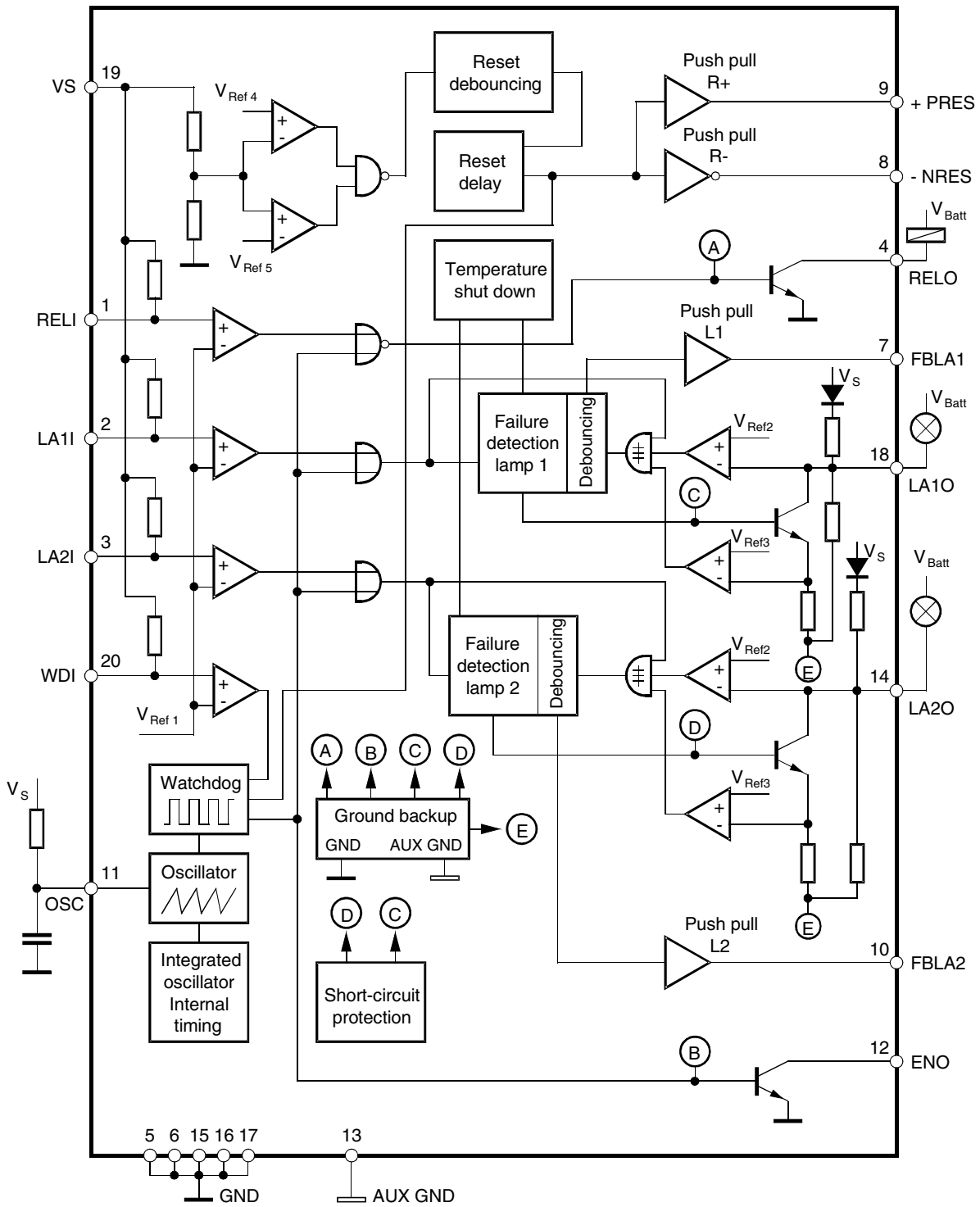


Table 1. Truth Table for Lamp Drivers and Lamp Feedback

Inputs			Outputs			Comment
Lamp (I)	Lamp Voltage	Lamp Current	Lamp Driver Current	Lamp Current	Feedback Lamp	
0	1	0	off	off	1	Output ok or open (internal pull-up) or shorted to V_{Batt}
0	1	1	on	off	1	Output shorted to V_{Batt} and faulty input level
0	0	1	on	on	0	Internal driver activated due to internal failure
0	0	0	off	on	0	Output shorted to GND
1	0	1	on	on	0	Output ok
1	1	1	on	off	1	Output shorted to V_{Batt}
1	1	0	off	off	1	Internal driver deactivated due to internal failure or thermal shutdown
1	0	0	off	on/off	1	Output shorted to GND or open

Explanation

Lamp voltage is logic 1 if output voltage > threshold voltage detection
 Lamp voltage is logic 0 if output voltage < threshold voltage detection
 Lamp current is logic 1 if output current > threshold current detection
 Lamp current is logic 0 if output current < threshold current detection

Table 2. Table of Fault Detection

Condition	Feedback Lamp	
	Lamp Input is 0 (Lamp off)	Lamp Input is 1 (Lamp on)
Normal operation	1	0
Lamp output shorted to GND	0 (= detection)	1 (= detection)
Lamp output shorted to V_{Batt}	1 (= no detection)	1 (= detection)
Lamp output open	1 (= no detection)	1 (= detection)
Feedback shorted to GND	0 (= detection)	0 (= no detection)
Feedback shorted to V_S	1 (= no detection)	1 (= detection)
Lamp input shorted to GND	1 (= no detection)	1 (= detection)
Lamp input shorted to V_S	0 (= detection)	0 (= no detection)

Fail-safe Functions

A fail-safe IC has to maintain its monitoring function even if there is a fault condition at one of the pins (e.g., short circuit). This ensures that a microcontroller system would not be brought into a critical status. A critical status is reached if the system is not able to actuate a warning lamp and switch off the relay. The following table shows fault conditions for different pins during which the IC still works as a fail-safe device.

Table 3. Table of Fault Condition

Pin	Function	Short to V_S	Short to V_{Batt}	Short to GND	Open Circuit
LA2O	Short-circuit proof driver for warning lamp	LA2O partly on	LA2O off	LA2O on	LA2O off
LA2I	Digital input to activate warning lamp	LA2O on	LA2O on	LA2O off	LA2O on
FBLA2	Digital feedback of warning lamp	Faulty feedback	Faulty feedback	Faulty feedback	Faulty feedback
LA1O	Short-circuit proof driver for warning lamp	LA1O partly on	LA1O off	LA1O on	LA1O off
LA1I	Digital input to activate warning lamp	LA1O on	LA1O on	LA1O off	LA1O on
FBLA1	Digital feedback of warning lamp	Faulty feedback	Faulty feedback	Faulty feedback	Faulty feedback
RELI	Digital input to activate the fail safe relay	Relay off	Relay off	Relay on	Relay off
WDI	Watchdog trigger input	Watchdog reset	Watchdog reset	Watchdog reset	Watchdog reset
OSC	Capacitor and resistor of watchdog	Watchdog reset	Watchdog reset	Watchdog reset	Watchdog reset

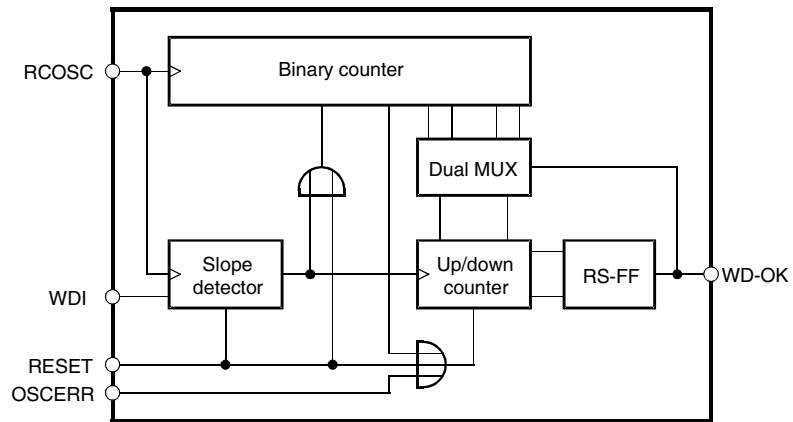
Description of the Watchdog

Abstract

The microcontroller is monitored by a digital window watchdog which accepts an incoming trigger signal of a constant frequency for correct operation. The frequency of the trigger signal can be varied in a broad range as the watchdog's time window is determined by external RC components.

The following description refers to Figure 1 on page 2.

Figure 4. Watchdog Block Diagram



WDI Input (Pin 20)

The microcontroller has to provide a trigger signal with the frequency f_{WDI} which is fed to the WDI input. A positive edge of f_{WDI} detected by a slope detector resets the binary and clocks the up/down counter additionally. The up/down counter only counts from 0 to 3 or reverse. Each correct trigger increments the up/down counter by 1, each wrong trigger decrements it by 1. As soon as the counter reaches the count of 3 the RS flip-flop is set (see Figure 5). A missing incoming trigger signal is detected after 250 clocks of the internal watchdog frequency f_{RC} (see WD-OK output) and resets the up/down counter directly.

RCOSC Input

With an external RC circuitry the IC generates a time base (frequency f_{RC}) independent from the microcontroller. The watchdog's time window refers to a frequency of

$$RC = 100 \times f_{WDI}$$

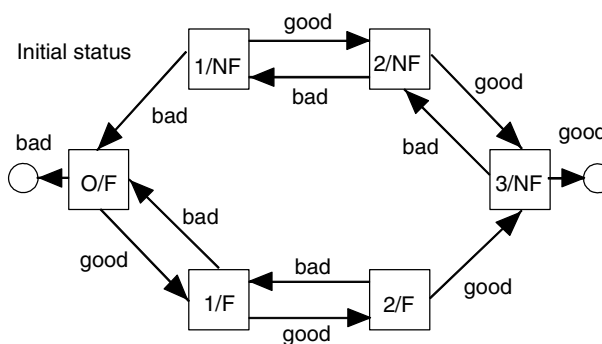
Reset Input

During power-on and under-/overvoltage detection a reset signal is fed to this pin. It resets the watchdog timer and sets the initial state.

WD - OK Output

After the up/down counter has been incremented to the count of 3 (see Figure 5, WD state diagram), the RS flip-flop is set and the WD-OK output becomes logic "1". This information is available for the microcontroller at the open-collector output ENO. If, on the other hand, the up/down counter is decremented to 0 the RS flip flop is reset, the WD OK output and the ENO output are disabled. The WD OK output also controls a dual MUX stage which shifts the time window by one clock after a successful trigger, thus forming a hysteresis to provide stable conditions for the evaluation of the trigger signal "good or false". The WD OK signal is also reset in case the watchdog counter is not reset after 250 clocks (missing trigger signal).

Watchdog State Diagram Figure 5. Watchdog State Diagram



Explanation

In each block, the first character represents the state of the counter. The second notation indicates the fault status of the counter. A fault status is indicated by an "F" and a no fault status is indicated by an "NF". When the watchdog is powered up initially, the counter starts at the 0/F block (initial state). "Good" indicates that a pulse has been received whose width resides within the timing window. "Bad" indicates that a pulse has been received whose width is either too short or too long.

Watchdog Window Calculation

Example with recommended values

$$C_{osc} = 3.3 \text{ nF} \quad (\text{should be preferably } 10\%, \text{ NPO})$$

$$R_{osc} = 39 \text{ k}\Omega \quad (\text{may be } 5\%, \quad R_{osc} < 100 \text{ k}\Omega \text{ due to leakage current and humidity})$$

RC Oscillator

$$t_{WDC} \text{ (s)} = 10^{-3} \times [C_{osc} \text{ (nF)} \times [(0.00078 \times R_{osc} \text{ (k}\Omega)) + 0.0005]]$$

$$f_{WDC} \text{ (Hz)} = 1/(t_{WDC})$$

Watchdog WDI

$$f_{WDI} \text{ (Hz)} = 0.01 \times f_{WDC}$$

$$t_{WDC} = 100 \text{ }\mu\text{s} \rightarrow f_{WDC} = 10 \text{ kHz}$$

$$f_{WDI} = 100 \text{ Hz} \rightarrow t_{WDI} = 10 \text{ ms}$$

WDI Pulse Width for Fault Detection After 3 Pulses

Upper watchdog window

$$\text{Minimum: } 169/f_{WDC} = 16.9 \text{ ms} \rightarrow f_{WDC}/169 = 59.1 \text{ Hz}$$

$$\text{Maximum: } 170/f_{WDC} = 17.0 \text{ ms} \rightarrow f_{WDC}/170 = 58.8 \text{ Hz}$$

Lower watchdog window

$$\text{Minimum: } 79/f_{WDC} = 7.9 \text{ ms} \rightarrow f_{WDC}/79 = 126.6 \text{ Hz}$$

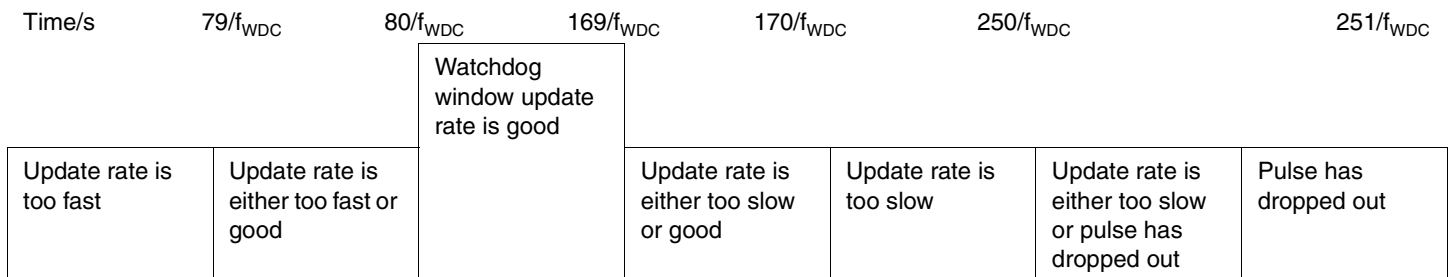
$$\text{Maximum: } 80/f_{WDC} = 8.0 \text{ ms} \rightarrow f_{WDC}/80 = 125.0 \text{ Hz}$$

WDI Dropouts for Immediate Fault Detection

$$\text{Minimum: } 250/f_{WDC} = 25 \text{ ms}$$

$$\text{Maximum: } 251/f_{WDC} = 25.1 \text{ ms}$$

Figure 6. Watchdog Timing Diagram with Tolerances



Remark to Reset Delay

The duration of the over- or undervoltage pulses determines the enable and reset output. A pulse duration shorter than the debounce time has no effect on the outputs. A pulse longer than the debounce time results in the first reset delay. If a pulse appears during this delay, a 2nd delay time is triggered. Therefore, the total reset delay time can be longer than specified in the datasheet.

Absolute Maximum Ratings

Stresses beyond those listed under “Absolute Maximum Ratings” may cause permanent damage to the device. This is a stress rating only and functional operation of the device at these or any other conditions beyond those indicated in the operational sections of this specification is not implied. Exposure to absolute maximum rating conditions for extended periods may affect device reliability.

Parameters	Symbol	Value	Unit
Supply voltage range	V_S	-0.2 to +16	V
AUX GND offset voltage to GND	V_{AUX}	±1.5	V
AUX GND offset current to GND	I_{AUX}	-600	mA
Power dissipation $V_S = 5\text{ V}$; $T_{amb} = 125^\circ\text{C}$	P_{tot}	700	mW
Thermal resistance	R_{thjc}	25	K/W
Junction temperature	T_j	150	°C
Ambient temperature range	T_{amb}	-40 to +125	°C
Storage temperature range	T_{stg}	-55 to +155	°C

Electrical Characteristics

$V_S = 5\text{ V}$, $T_{amb} = -40\text{ to }+125^\circ\text{C}$; reference pin is GND; $f_{intern} = 100\text{ kHz} + 50\% - 45\%$, $f_{WDC} = 10\text{ kHz} \pm 10\%$; $f_{WDI} = 100\text{ Hz}$

Parameters	Test Conditions	Symbol	Min.	Typ.	Max.	Unit
Supply Voltage						
Operation range general		V_S	4.5		5.5	V
Operation range reset		V_S	1.5		16.0	V
Supply Current						
Lamp driver on, relay off	$T_{amb} = -40^\circ\text{C}$ $T_{amb} = 125^\circ\text{C}$				40 35	mA mA
Lamp driver off, relay on	$T_{amb} = -40^\circ\text{C}$ $T_{amb} = 125^\circ\text{C}$				25 20	mA mA
Lamp driver off, relay off	$T_{amb} = -40^\circ\text{C}$ $T_{amb} = 125^\circ\text{C}$				15 10	mA mA
Auxiliary Ground (AUX GND)						
AUX GND offset voltage operation range	$T_{amb} = -40^\circ\text{C}$ $T_{amb} = 90^\circ\text{C}$ $T_{amb} = 125^\circ\text{C}$		-1.2 -0.65 -0.5		1.2 1.0 0.8	V V V
AUX GND offset voltage to GND	$I_{AUX} = -600\text{ mA}$		-1.7		3.0	V
Digital Inputs (LA1I, LA2I, REL1 and WDI)						
Detection low			-0.2		$0.2 \times V_S$	V
Detection high			$0.7 \times V_S$		$V_S + 0.5\text{ V}$	V
Resistance to V_S			10		40	kΩ
Input current low	Input voltage = 0 V		100		550	μA
Input current high	Input voltage = V_S		-5		5	μA

Electrical Characteristics (Continued)

$V_S = 5\text{ V}$, $T_{\text{amb}} = -40\text{ to }+125^\circ\text{C}$; reference pin is GND; $f_{\text{intern}} = 100\text{ kHz} + 50\% - 45\%$, $f_{\text{WDC}} = 10\text{ kHz} \pm 10\%$; $f_{\text{WDI}} = 100\text{ Hz}$

Parameters	Test Conditions	Symbol	Min.	Typ.	Max.	Unit
Digital Outputs; Lamp Driver Feedbacks (FBLA1, FBLA2)						
Voltage low	$I \leq 1.6\text{ mA}$		0		0.5	V
Voltage high	$I \leq 10\text{ A}$ $10\text{ A} \leq I \leq 1.6\text{ mA}$		$0.8 \times V_S$ $0.7 \times V_S + 0.1$		V_S	V
Threshold voltage detection			$0.4 \times V_S$		$0.5 \times V_S$	V
Threshold current detection			10		50	mA
Digital Outputs (PRES and NRES)						
Voltage high	$I \leq 100\text{ A}$		$0.7 \times V_S + 0.1$		V_S	V
Voltage low	$I \leq 1\text{ mA}$		0		0.3	V
Digital Output (ENO) with Open Collector						
Saturation voltage low	$I \leq 25\text{ mA}$		0		0.3	V
Clamping voltage			26		30	V
Current limit low			25			mA
Leakage current	$V_{\text{ENO}} = 5\text{ V}$ $V_{\text{ENO}} = 16\text{ V}$ $V_{\text{ENO}} = 26\text{ V}$				20 100 200	μA μA μA
Lamp Drivers (LA10 and LA20) with Integrated Pull-up Resistor						
Saturation voltage	$I \leq 125\text{ mA}$; $V_S = 5\text{ V}$ $I \leq 125\text{ mA}$; $V_S = 0\text{ V}$				0.5 1.5	V V
Saturation voltage 250 mA requires enhanced heat sink	$I \leq 250\text{ mA}$; $V_S = 5\text{ V}$ $I \leq 250\text{ mA}$; $V_S = 0\text{ V}$ $I \leq 250\text{ mA}$; no GND				1.0 2.0 3.0	V V V
Maximum load current	$T_{\text{amb}} = 90^\circ\text{C}$ $T_{\text{amb}} = 125^\circ\text{C}$		250 180			mA mA
Clamping voltage			26		30	V
Leakage current	$V_{\text{LA10, LA20}} = 16\text{ V}$ $V_{\text{LA10, LA20}} = 26\text{ V}$				1 3	mA mA
Threshold current limitation			0.5		1.0	A
Pull-up resistor			2		17	k Ω
Relay Driver (RELO)						
Saturation voltage	$I \leq 250\text{ mA}$				0.5	V
Maximum load current	$T_{\text{amb}} = 90^\circ\text{C}$ $T_{\text{amb}} = 125^\circ\text{C}$		250 200			mA mA
Clamping voltage			26		30	V
Leakage current	$V_{\text{Batt}} = 16\text{ V}$ $V_{\text{Batt}} = 26\text{ V}$				20 200	μA μA
Reset and V_S Control						
Lower reset level		V_S	4.5		4.8	V
Upper reset level		V_S	5.2		5.5	V
Hysteresis			25			mV
Reset debounce time			120		500	μs

Electrical Characteristics (Continued)

$V_S = 5\text{ V}$, $T_{\text{amb}} = -40\text{ to }+125^\circ\text{C}$; reference pin is GND; $f_{\text{intern}} = 100\text{ kHz} + 50\% - 45\%$, $f_{\text{WDC}} = 10\text{ kHz} \pm 10\%$; $f_{\text{WDI}} = 100\text{ Hz}$

Parameters	Test Conditions	Symbol	Min.	Typ.	Max.	Unit
Reset delay			20		80	ms
Watchdog Timing						
Feedback reaction time (FBLA1, FBLA2)	No fault, edge at LA11, LA21	t_{FB}	2.56		12.8	ms
Minimum lamp input toggle time for a secure feedback reaction	No fault, pulse at LA11, LA21	$t_{\text{P,FB}}$	10.24			ms
Power-on-reset prolongation time		t_{POR}	34.3		103.1	ms
Detection time for RC-oscillator fault	$V_{\text{RC}} = \text{constant}$	t_{RCerror}	81.9		246	ms
Time interval for over-/undervoltage detection		$t_{\text{D,OUV}}$	0.16		0.64	ms
Reaction time of NRES output on over-/undervoltage		$t_{\text{R,OUV}}$	0.187		0.72	ms
Minimum toggle time for a secure broken ground detection		$t_{\text{P,BGND}}$	13.3			μs
Maximum reaction time for broken ground detection		$t_{\text{R,BGND}}$			100	μs
Nominal frequency for WDI	$f_{\text{RC}} = 100 \times f_{\text{WDI}}$	f_{WDI}	10		130	Hz
Nominal frequency for RC	$f_{\text{WDI}} = 1/100 \times f_{\text{RC}}$	f_{RC}	1		13	kHz
Minimum pulse duration for a secure WDI input pulse detection		$t_{\text{P,WDI}}$	182			μs
Frequency range for a correct WDI signal		f_{WDI}	64.7		112.5	Hz
Number of incorrect WDI trigger counts for locking the outputs		n_{lock}		3		
Number of correct WDI trigger counts for releasing the outputs		n_{release}		3		
Detection time for a stuck WDI signal	$V_{\text{WDI}} = \text{constant}$	t_{WDIerror}	24.5		25.5	ms
Watchdog Timing Relative to f_{RC}						
Minimum pulse duration for a securely WDI input pulse detection				2		cycles
Frequency range for a correct WDI signal			80		170	cycles
Hysteresis range at the WDI ok margins				1		cycle
Detection time for a stuck WDI signal	$V_{\text{WDI}} = \text{constant}$		250		251	cycles

Protection Against Transient Voltages According to ISO TR 7637-3 Level 4 (Except Pulse 5)

Pulse	Voltage	Source Resistance ⁽¹⁾	Rise Time	Duration	Amount
1	-110 V	10 Ω	100 V/s	2 ms	15.000
2	+110 V	10 Ω	100 V/s	0.05 ms	15.000
3a	-160 V	50 Ω	30 V/ns	0.1 s	1 h
3b	+150 V	50 Ω	20 V/ns	0.1 s	1 h
5	40 V	2 Ω	10 V/ms	250 ms	20

Notes: 1. Lamp drivers: 1.2 Ω lamps need to be added to the source resistance.
 Relay driver: relay coil with $R_{\min} = 70 \Omega$ need to be added to the source resistance.

Application Hints

- The lamp output pins LA1O and LA2O may need to be protected by external protection diodes against reversed battery (e.g., BAV 202) in order to avoid a reset during negative pulses.
- If pilot lamps with a wattage of $P > 1.2 \text{ W}$ are connected, external Zener diodes are mandatory.

Timing Diagrams

Figure 7. Watchdog in Too Fast Condition

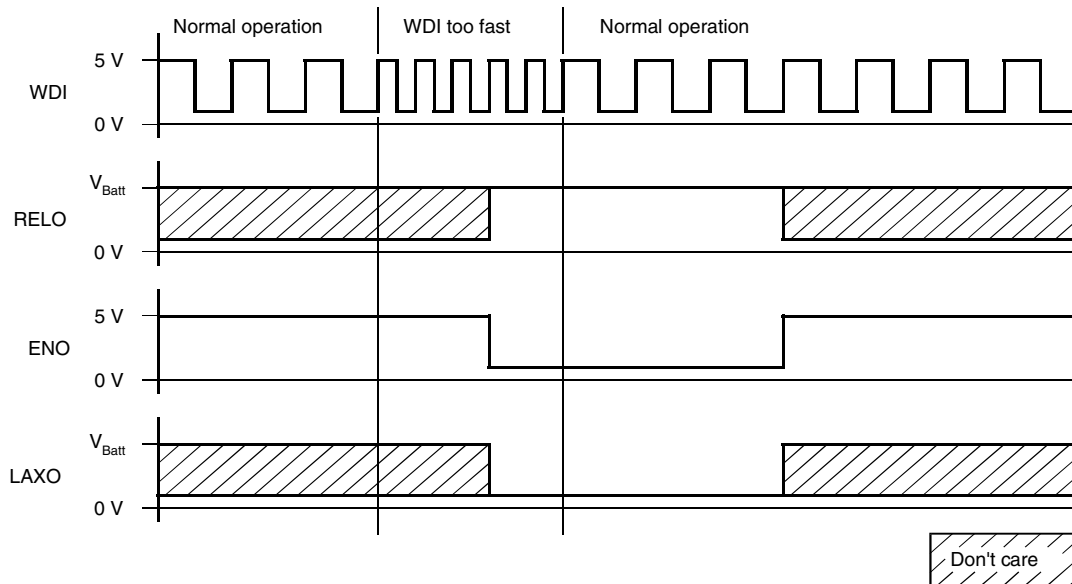


Figure 8. Watchdog in Too Slow Condition

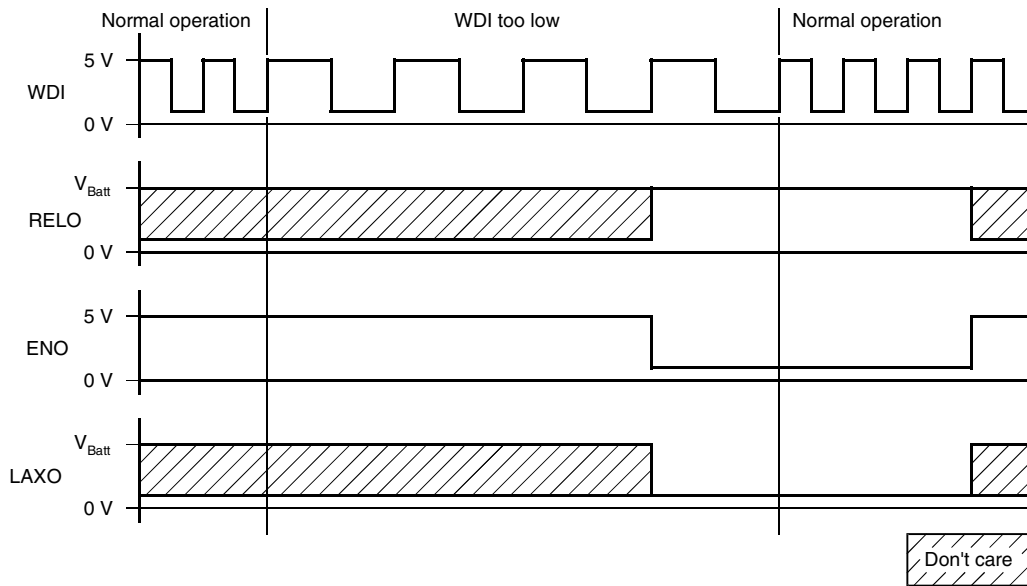


Figure 9. Overvoltage Condition

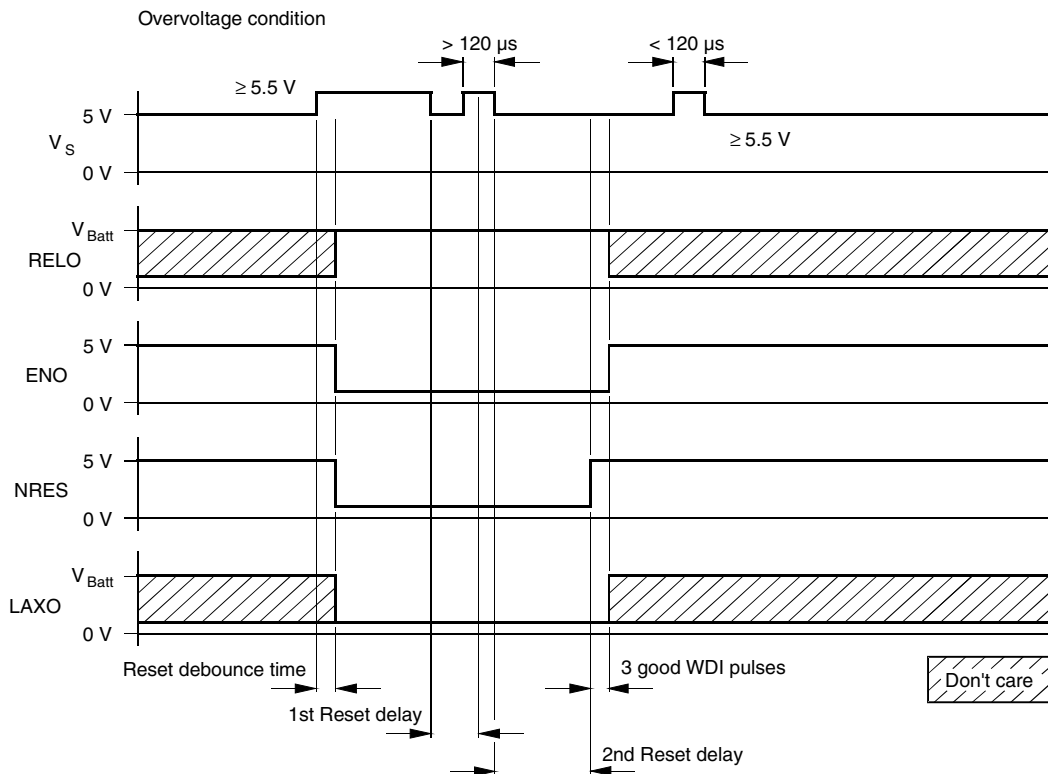
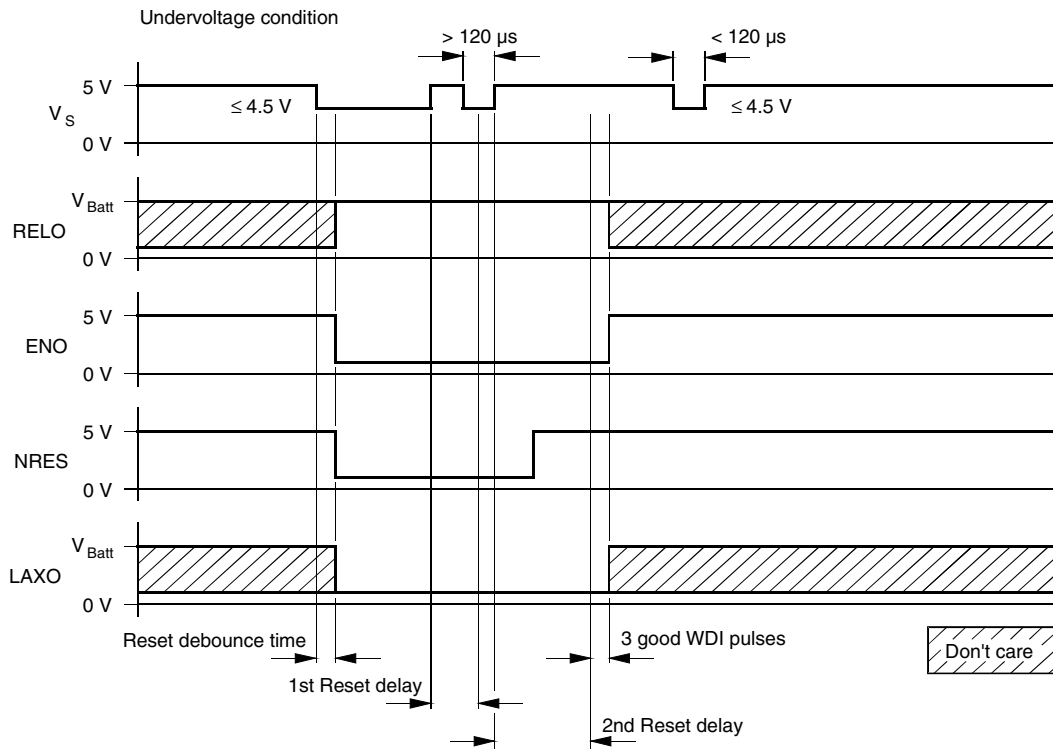


Figure 10. Undervoltage Condition



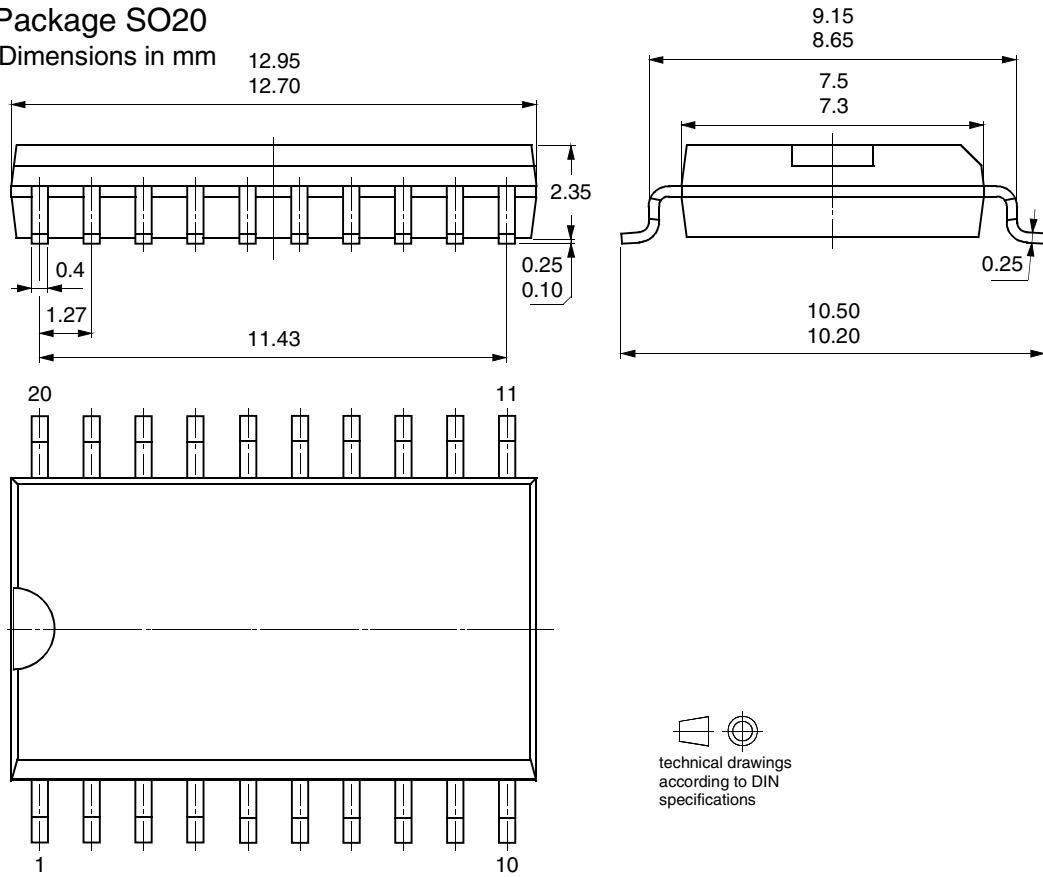
Ordering Information


Extended Type Number	Package	Remarks
U6809B	SO20 special lead frame	–

Package Information

Package SO20

Dimensions in mm




 technical drawings
 according to DIN
 specifications



Atmel Corporation

2325 Orchard Parkway
San Jose, CA 95131, USA
Tel: 1(408) 441-0311
Fax: 1(408) 487-2600

Regional Headquarters

Europe

Atmel Sarl
Route des Arsenaux 41
Case Postale 80
CH-1705 Fribourg
Switzerland
Tel: (41) 26-426-5555
Fax: (41) 26-426-5500

Asia

Room 1219
Chinachem Golden Plaza
77 Mody Road Tsimshatsui
East Kowloon
Hong Kong
Tel: (852) 2721-9778
Fax: (852) 2722-1369

Japan

9F, Tonetsu Shinkawa Bldg.
1-24-8 Shinkawa
Chuo-ku, Tokyo 104-0033
Japan
Tel: (81) 3-3523-3551
Fax: (81) 3-3523-7581

Atmel Operations

Memory

2325 Orchard Parkway
San Jose, CA 95131, USA
Tel: 1(408) 441-0311
Fax: 1(408) 436-4314

Microcontrollers

2325 Orchard Parkway
San Jose, CA 95131, USA
Tel: 1(408) 441-0311
Fax: 1(408) 436-4314

La Chantrerie
BP 70602
44306 Nantes Cedex 3, France
Tel: (33) 2-40-18-18-18
Fax: (33) 2-40-18-19-60

ASIC/ASSP/Smart Cards

Zone Industrielle
13106 Rousset Cedex, France
Tel: (33) 4-42-53-60-00
Fax: (33) 4-42-53-60-01

1150 East Cheyenne Mtn. Blvd.
Colorado Springs, CO 80906, USA
Tel: 1(719) 576-3300
Fax: 1(719) 540-1759

Scottish Enterprise Technology Park
Maxwell Building
East Kilbride G75 0QR, Scotland
Tel: (44) 1355-803-000
Fax: (44) 1355-242-743

RF/Automotive

Theresienstrasse 2
Postfach 3535
74025 Heilbronn, Germany
Tel: (49) 71-31-67-0
Fax: (49) 71-31-67-2340

1150 East Cheyenne Mtn. Blvd.
Colorado Springs, CO 80906, USA
Tel: 1(719) 576-3300
Fax: 1(719) 540-1759

Biometrics/Imaging/Hi-Rel MPU/ High Speed Converters/RF Datacom

Avenue de Rochepleine
BP 123
38521 Saint-Egreve Cedex, France
Tel: (33) 4-76-58-30-00
Fax: (33) 4-76-58-34-80

Literature Requests

www.atmel.com/literature

Disclaimer: Atmel Corporation makes no warranty for the use of its products, other than those expressly contained in the Company's standard warranty which is detailed in Atmel's Terms and Conditions located on the Company's web site. The Company assumes no responsibility for any errors which may appear in this document, reserves the right to change devices or specifications detailed herein at any time without notice, and does not make any commitment to update the information contained herein. No licenses to patents or other intellectual property of Atmel are granted by the Company in connection with the sale of Atmel products, expressly or by implication. Atmel's products are not authorized for use as critical components in life support devices or systems.

© Atmel Corporation 2003. All rights reserved.

Atmel® and combinations thereof are the registered trademarks of Atmel Corporation or its subsidiaries.

Other terms and product names may be the trademarks of others.



Printed on recycled paper.