

阅读申明

- 1.本站收集的数据手册和产品资料都来自互联网，版权归原作者所有。如读者和版权方有任何异议请及时告之，我们将妥善解决。
- 2.本站提供的中文数据手册是英文数据手册的中文翻译，其目的是协助用户阅读，该译文无法自动跟随原稿更新，同时也可能存在翻译上的不当。建议读者以英文原稿为参考以便获得更精准的信息。
- 3.本站提供的产品资料，来自厂商的技术支持或者使用者的心得体会等，其内容可能存在描述上的差异，建议读者做出适当判断。
- 4.如需与我们联系，请发邮件到marketing@iczoom.com，主题请标有“数据手册”字样。

Read Statement

1. The datasheets and other product information on the site are all from network reference or other public materials, and the copyright belongs to the original author and original published source. If readers and copyright owners have any objections, please contact us and we will deal with it in a timely manner.
2. The Chinese datasheets provided on the website is a Chinese translation of the English datasheets. Its purpose is for reader's learning exchange only and do not involve commercial purposes. The translation cannot be automatically updated with the original manuscript, and there may also be improper translations. Readers are advised to use the English manuscript as a reference for more accurate information.
3. All product information provided on the website refer to solutions from manufacturers' technical support or users the contents may have differences in description, and readers are advised to take the original article as the standard.
4. If you have any questions, please contact us at marketing@iczoom.com and mark the subject with "Datasheets" .

FAN7310

LCD Backlight Inverter Drive Integrated Circuit

Features

- High-Efficiency, Single-Stage Power Conversion
- Wide Input Voltage Range: 5V to 24V
- Backlight Lamp Ballast and Soft Dimming
- Reduce External Components
- Precision Voltage Reference Trimmed to 2%
- ZVS full-bridge topology
- Soft-Start Feature
- PWM Control at Fixed Frequency
- Analog and Burst Dimming Function
- Synchronizable Switching Frequency with External Signal
- Open-Lamp Protection
- Open-Lamp Regulation
- 20-Pin SSOP

Applications

- LCD TV
- LCD Monitor

Description

The FAN7310 provides all the control functions for a series parallel resonant converter and contains a pulse width modulation (PWM) controller to develop a supply voltage. Typical operating frequency range is between 30kHz and 250kHz, depending on the CCFL and the transformer's characteristics. The FAN7310 has a patent-pending on phase-shift control.

20-SSOP

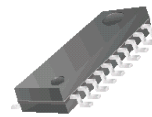

Ordering Information

Part Number	Package	Pb-Free	Operating Temperature Range	Packing Method
FAN7310G	20-SSOP	Yes	-25°C ~ 85°C	Rail
FAN7310GX	20-SSOP	Yes		Tape & Reel

Typical Application

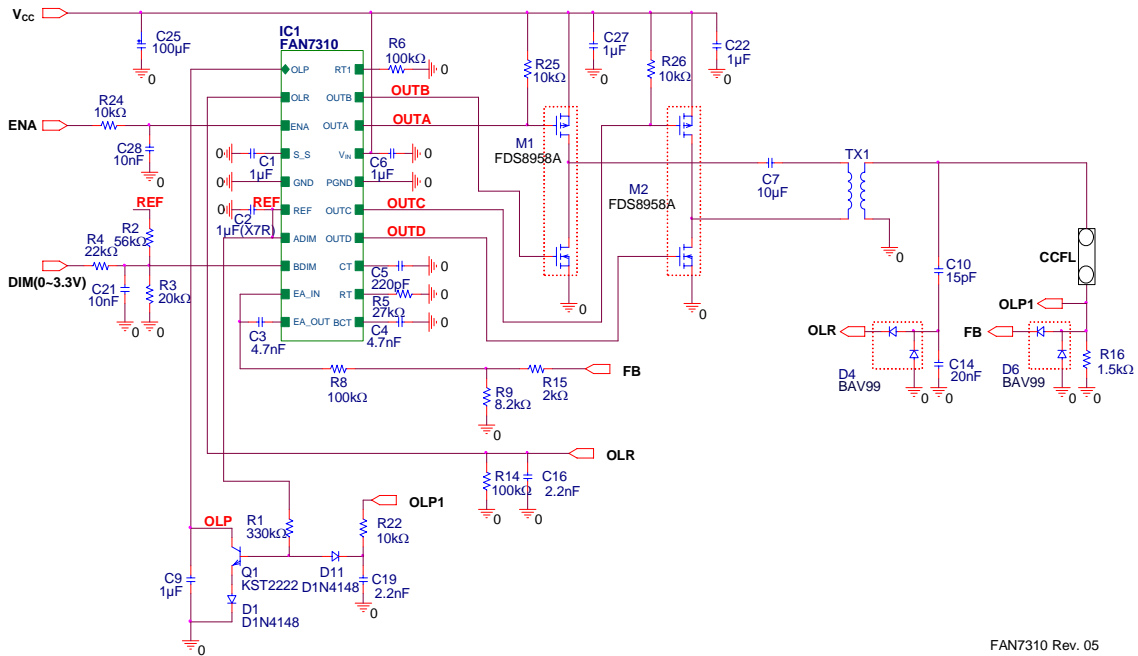

FAN7310 Rev. 05

Figure 1. Application Circuit for CCFL

Internal Block Diagram

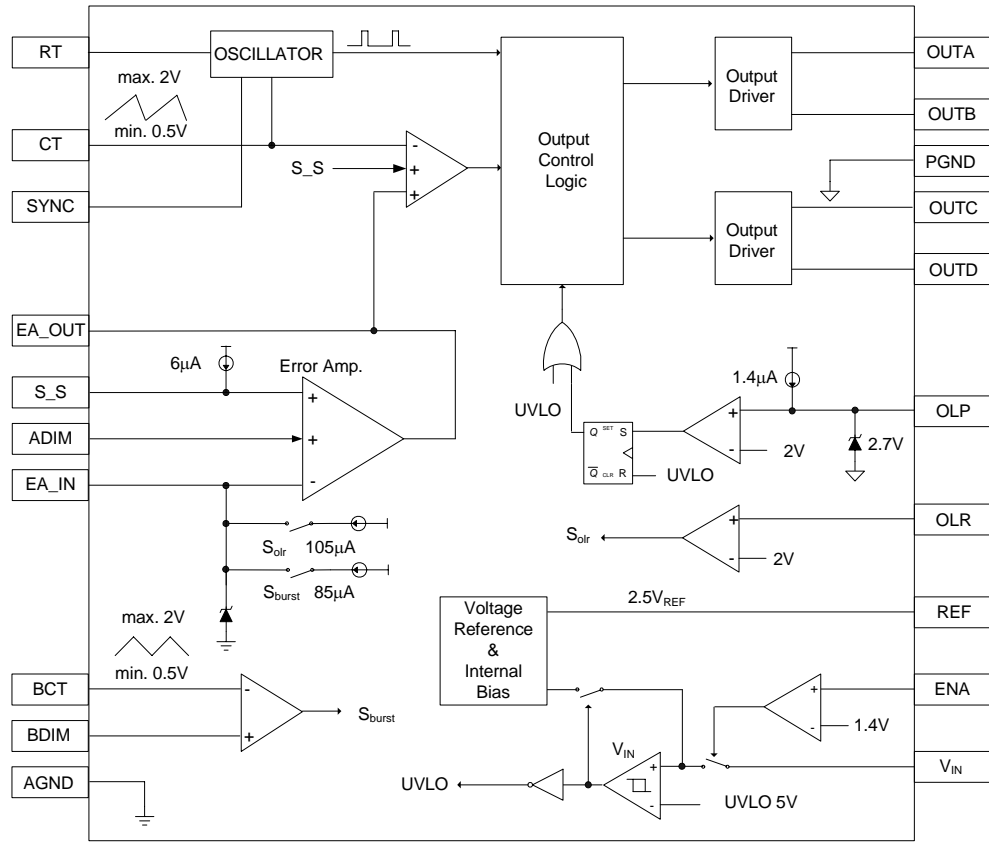

FAN7310 Rev.03

Figure 2. Functional Block Diagram



TRADEMARKS

The following are registered and unregistered trademarks and service marks Fairchild Semiconductor owns or is authorized to use and is not intended to be an exhaustive list of all such trademarks.

ACE [®]	Green FPS [™] e-Series [™]	Power-SPM [™]	SyncFET [™]
Build it Now [™]	GTO [™]	PowerTrench [®]	The Power Franchise [®]
CorePLUS [™]	<i>i-Lo</i> [™]	Programmable Active Droop [™]	 ™
CROSSVOLT [™]	IntelliMAX [™]	QFET [®]	TinyBoost [™]
CTL [™]	ISOPLANAR [™]	QS [™]	TinyBuck [™]
Current Transfer Logic [™]	MegaBuck [™]	QT Optoelectronics [™]	TinyLogic [®]
EcoSPARK [®]	MICROCOUPLER [™]	Quiet Series [™]	TINYOPTO [™]
FACT Quiet Series [™]	MicroPak [™]	RapidConfigure [™]	TinyPower [™]
FACT [®]	Motion-SPM [™]	SMART START [™]	TinyPWM [™]
FAST [®]	OPTOLOGIC [®]	SPM [®]	TinyWire [™]
FastvCore [™]	OPTOPLANAR [®]	STEALTH [™]	μSerDes [™]
FPS [™]	PDP-SPM [™]	SuperFET [™]	UHC [®]
FRFET [®]	Power220 [®]	SuperSOT [™] -3	UniFET [™]
Global Power Resource SM	Power247 [®]	SuperSOT [™] -6	VCX [™]
Green FPS [™]	POWEREDGE [®]	SuperSOT [™] -8	

DISCLAIMER

FAIRCHILD SEMICONDUCTOR RESERVES THE RIGHT TO MAKE CHANGES WITHOUT FURTHER NOTICE TO ANY PRODUCTS HEREIN TO IMPROVE RELIABILITY, FUNCTION, OR DESIGN. FAIRCHILD DOES NOT ASSUME ANY LIABILITY ARISING OUT OF THE APPLICATION OR USE OF ANY PRODUCT OR CIRCUIT DESCRIBED HEREIN; NEITHER DOES IT CONVEY ANY LICENSE UNDER ITS PATENT RIGHTS, NOR THE RIGHTS OF OTHERS. THESE SPECIFICATIONS DO NOT EXPAND THE TERMS OF FAIRCHILD'S WORLDWIDE TERMS AND CONDITIONS, SPECIFICALLY THE WARRANTY THEREIN, WHICH COVERS THESE PRODUCTS.

LIFE SUPPORT POLICY

FAIRCHILD'S PRODUCTS ARE NOT AUTHORIZED FOR USE AS CRITICAL COMPONENTS IN LIFE SUPPORT DEVICES OR SYSTEMS WITHOUT THE EXPRESS WRITTEN APPROVAL OF FAIRCHILD SEMICONDUCTOR CORPORATION.

As used herein:

1. Life support devices or systems are devices or systems which, (a) are intended for surgical implant into the body or (b) support or sustain life, and (c) whose failure to perform when properly used in accordance with instructions for use provided in the labeling, can be reasonably expected to result in a significant injury of the user.
2. A critical component in any component of a life support, device, or system whose failure to perform can be reasonably expected to cause the failure of the life support device or system, or to affect its safety or effectiveness.

PRODUCT STATUS DEFINITIONS

Definition of Terms

Datasheet Identification	Product Status	Definition
Advance Information	Formative or In Design	This datasheet contains the design specifications for product development. Specifications may change in any manner without notice.
Preliminary	First Production	This datasheet contains preliminary data; supplementary data will be published at a later date. Fairchild Semiconductor reserves the right to make changes at any time without notice to improve design.
No Identification Needed	Full Production	This datasheet contains final specifications. Fairchild Semiconductor reserves the right to make changes at any time without notice to improve design.
Obsolete	Not In Production	This datasheet contains specifications on a product that has been discontinued by Fairchild Semiconductor. The datasheet is printed for reference information only.

Rev. I28