

## 阅读申明

- 1.本站收集的数据手册和产品资料都来自互联网，版权归原作者所有。如读者和版权方有任何异议请及时告之，我们将妥善解决。
- 2.本站提供的中文数据手册是英文数据手册的中文翻译，其目的是协助用户阅读，该译文无法自动跟随原稿更新，同时也可能存在翻译上的不当。建议读者以英文原稿为参考以便获得更精准的信息。
- 3.本站提供的产品资料，来自厂商的技术支持或者使用者的心得体会等，其内容可能存在描述上的差异，建议读者做出适当判断。
- 4.如需与我们联系，请发邮件到marketing@iczoom.com，主题请标有“数据手册”字样。

## Read Statement

1. The datasheets and other product information on the site are all from network reference or other public materials, and the copyright belongs to the original author and original published source. If readers and copyright owners have any objections, please contact us and we will deal with it in a timely manner.
2. The Chinese datasheets provided on the website is a Chinese translation of the English datasheets. Its purpose is for reader's learning exchange only and do not involve commercial purposes. The translation cannot be automatically updated with the original manuscript, and there may also be improper translations. Readers are advised to use the English manuscript as a reference for more accurate information.
3. All product information provided on the website refer to solutions from manufacturers' technical support or users the contents may have differences in description, and readers are advised to take the original article as the standard.
4. If you have any questions, please contact us at marketing@iczoom.com and mark the subject with "Datasheets" .

## Features

- Interval Pause: 4 to 20 s
- After-wiping Time: 2 to 20 s
- Wiper Motor's Park Switch
- 0.6 s Prewash Delay
- Wipe/Wash Mode Priority
- One External Capacitor Determines All Time Sequences
- Relay Driver with Z-diode
- Interference Protection According to VDE 0839 or ISO/TR 7637/1
- Load-dump Protected

## Description

The U641B is a bi-polar integrated circuit designed for the wiper application in the automotive market. It includes wipe, wash and interval mode.

## Functional Description

As a convenience feature of the windshield wiper, intermittent and wipe/wash operation functions are implemented in most of the automobiles. The U641B is a cost-effective solution for an accurate timing function control. Wipe/wash mode has priority over interval mode. Interval pause and after-wiping time can be set to fixed values by using resistors in a broad time range. Added value can be provided with an individual, continuous adjustment of the interval pause by a potentiometer which may be built into the stalk. For proper operation, it is mandatory to feed the signal of the wiper motor's park switch into the U641B.

Figure 1. Block Diagram

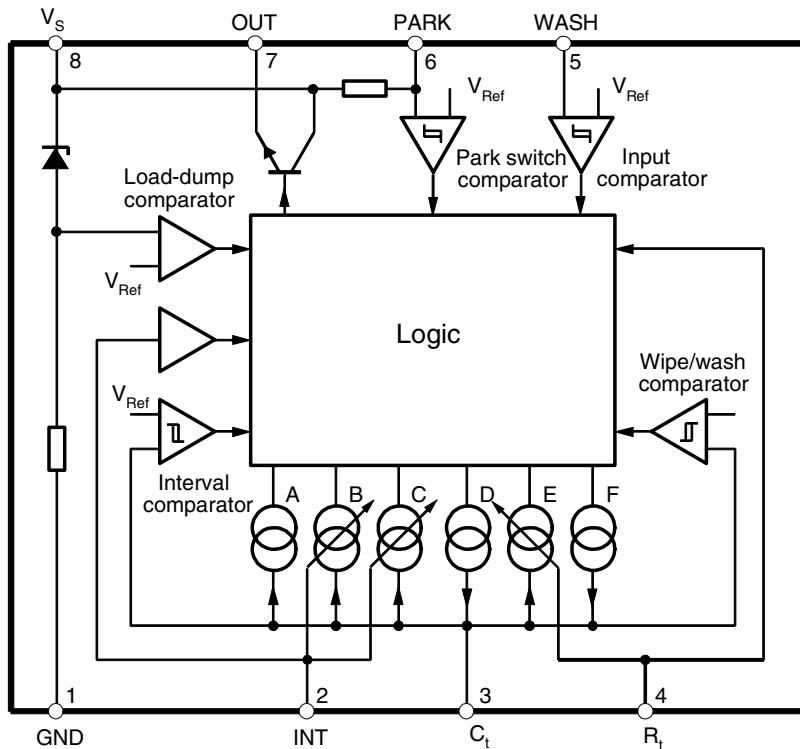

## Interval and Wipe/Wash Wiper Control IC with Delay

## U641B

## Pin Configuration

Figure 2. Pinning

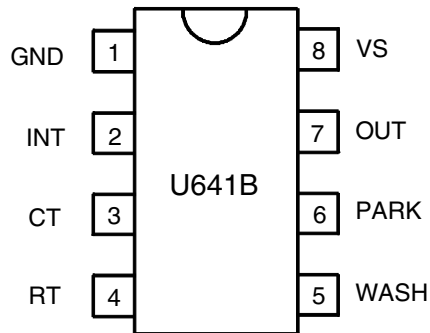

## Pin Description

Pin	Symbol	Function
1	GND	Ground
2	INT	Interval switch
3	CT	Timing capacitor $C_2$
4	RT	After-wiping time resistance
5	WASH	Wipe/wash switch
6	PARK	Park switch for wiper motor
7	OUT	Relay control output
8	VS	Supply voltage terminal 15

## Circuit Description

### Interval Function, Pin 2

By closing the interval switch,  $S_2$ , to supply voltage,  $V_{Batt}$ , the relay is activated. The internal current source (pin 3) which holds the capacitor  $C_2$  in charged state is switched-off. As soon as there is a positive potential at the park switch ( $S_1$ ), current source F (see Figure 1 on page 1) charges the capacitor  $C_2$  very quickly. After the wiper operation is finished,  $S_1$  is again at ground potential, the relay is in the off position - interval pause begins - the capacitor  $C_2$  is discharged through the current source C, till the voltage at pin 3 is below the threshold of 2 V. Interval pause can be adjusted between 4 s to 20 s with the help of potentiometer  $R_3$ . Now the relay switches on and the next interval cycle begins. Opening switch  $S_2$  causes current source A to discharge  $C_2$  immediately and current sources C and F are switched off.

### Wipe/Wash (WIWA) Operation, Pin 5

By closing the WIWA switch,  $S_3$ , to supply voltage,  $V_{Batt}$ , the water pump starts spraying the water on the windshield. During this function, the current source A is switched-off which keeps the capacitor  $C_2$  in a discharged state. Now the capacitor is charged through the current source F. If (after a time interval of approximately 600 ms) the voltage at the capacitor is greater than 6.1 V, the relay is turned on as long as the switch WIWA is closed.

The after-wiping time begins when the switch is open, the sources D and F are switched off and the source E is activated. Source E discharges the capacitor until the voltage is less than 2.2 V. The relay is off and the wiper-motor is supplied via the park switch until the park position is reached. The after-wiping time is determined by the current source E which can be regulated with the external resistor  $R_{Time}$ . When the after-wiping time has elapsed, the source A discharges the capacitor. The relay switch is independent of the park switch  $S_1$ .

### Interval and WIWA Functions

The interval function is interrupted immediately when the switch  $S_2$  is activated. The current source A discharges the capacitor to a value of 2 V, afterwards, the normal wash function starts.

Interval wiping starts immediately when the after-wipe time is over. The switching delays are slightly shorter, because the capacitor is already charged to a value of 2 V.

The Wipe/Wash function is not interrupted when the interval switch  $S_2$  is activated. The interval function begins after the WIWA function has elapsed.

**Figure 3.** Application Circuit with Interval and Wipe/Wash Operation

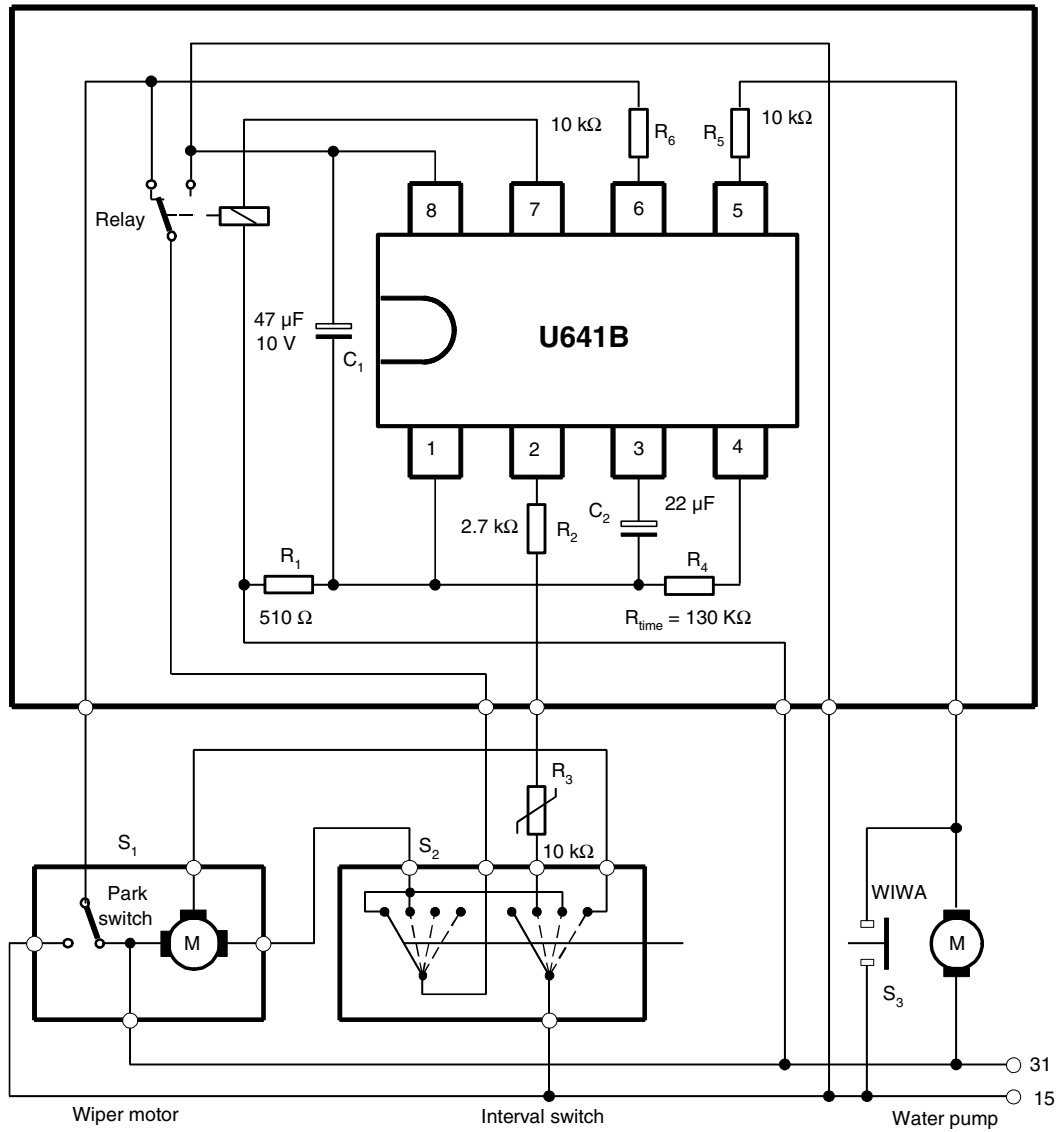

## Absolute Maximum Ratings

Stresses beyond those listed under “Absolute Maximum Ratings” may cause permanent damage to the device. This is a stress rating only and functional operation of the device at these or any other conditions beyond those indicated in the operational sections of this specification is not implied. Exposure to absolute maximum rating conditions for extended periods may affect device reliability.

Parameters	Pin	Symbol	Value	Unit
Supply voltage $t = 60$ s, terminal 15	8	$V_{\text{Batt}}$	28	V
Supply current $t = 2$ ms	8	$I_8$	1.5	A
$t = 200$ ms		$I_8$	150	mA
Relay control output current (DC) $t = 200$ ms	7	$I_7$	200	mA
		$I_7$	1.2	A
<b>Pulse Current (Control Inputs) <math>t = 200</math> ms</b>				
Park switch, $S_1$	6	$I_6$	50	mA
Wipe/Wash switch, $S_3$	5	$I_5$	50	
Interval switch, $S_2$	2	$I_2$	50	
Power dissipation $T_{\text{amb}} = 90^\circ\text{C}$		$P_{\text{tot}}$	500	mW
Storage temperature range		$T_{\text{stg}}$	-55 to +125	$^\circ\text{C}$
Ambient temperature range		$T_{\text{amb}}$	-40 to +85	$^\circ\text{C}$

## Thermal Resistance

Parameters		Symbol	Value	Unit
Junction ambient	DIP8	$R_{\text{thJA}}$	120	K/W
	SO8	$R_{\text{thJA}}$	160	K/W

## Electrical Characteristics

$V_{Batt} = 12\text{ V}$ ,  $T_{amb} = 25^\circ\text{C}$ , reference point is pin 8 (see Figure 3 on page 4) unless otherwise specified.

Parameters	Test Conditions	Pin	Symbol	Min.	Typ.	Max.	Unit
Supply voltage		8	$V_{Batt}$	9		16.5	V
Supply current			$I_8$		10		mA
Z-diode limitation			$V_1$		7.6		V
<b>Overvoltage</b>							
Threshold current			$I_1$		-50		mA
Threshold voltage			$V_{Batt}$		35		V
<b>Relay Control Output</b>		7					
Saturation voltage	$I_7 = 100\text{ mA}$ $I_7 = 200\text{ mA}$		$V_7$			-1.0 -1.5	V
Leakage current			$I_7$		100		$\mu\text{A}$
<b>Park Switch</b>		6					
Internal pull-up resistance	$R_6 = 10\text{ k}\Omega$		$R_6$		50		$\text{k}\Omega$
Switching threshold voltage			$V_6$		-3.3		V
Protection diode	$I_6 = -10\text{ mA}$ $I_6 = 10\text{ mA}$		$V_6$		-0.8		V
			$V_6$		7.6		V
<b>Input C<sub>t</sub></b>		3					
Internal resistance			$R_3$		100		$\Omega$
<b>Interval Input</b>		$R_2 = 2.7\text{ to }30\text{ k}\Omega$ 2					
Protection diode	$I_2 = -10\text{ mA}$ $I_2 = 30\text{ mA}/10\text{ ms}$		$V_2$		-0.8 7.6		V
<b>WASH Input</b>		$R_5 = 10\text{ k}\Omega$ 5					
Switching threshold/ Hysteresis			$V_5$		-1.4/ -5.4		V
Protection diode	$I_5 = -10\text{ mA}$ $I_5 = 10\text{ mA}$		V		-0.8 7.6		V
<b>Switching Characteristics</b>		$R_4 = 47\text{ k}\Omega\text{ to }300\text{ k}\Omega$ , $I_4 = -150\text{ }\mu\text{A}$					
Interval time	$R_3 = 0\text{ k}\Omega$ $R_3 = 10\text{ k}\Omega$		$t_2$	3.6 10.8	4 12	4.4 13.2	s
Prewash delay			$t_{del}$		600		ms
After-wipe-time	$R_4 = 130\text{ k}\Omega$	5	$t_5$	4.75	5.25	5.75	s

Diagrams

Figure 4. Interval Pause = f (T);  $C_t = 22 \mu\text{F}$

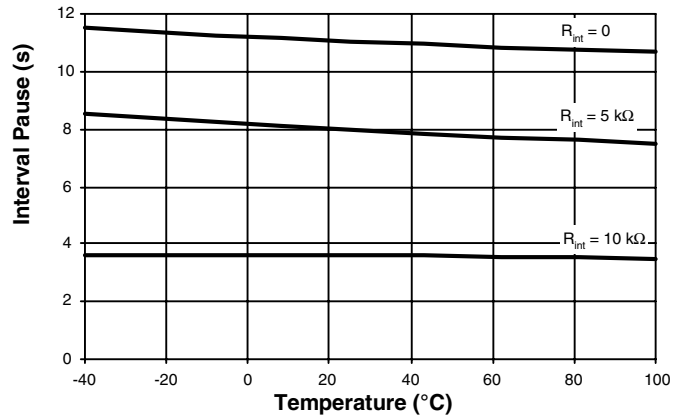

Figure 5. After-wiping Time = f (T);  $C_t = 22 \mu\text{F}$ ;  $V_{Batt} = 8 \text{ V}$

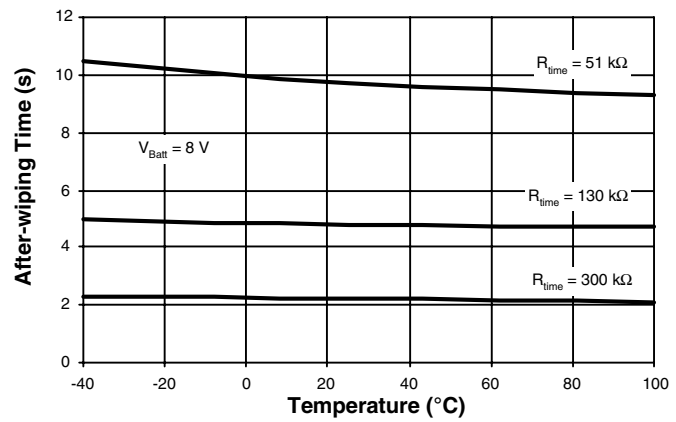
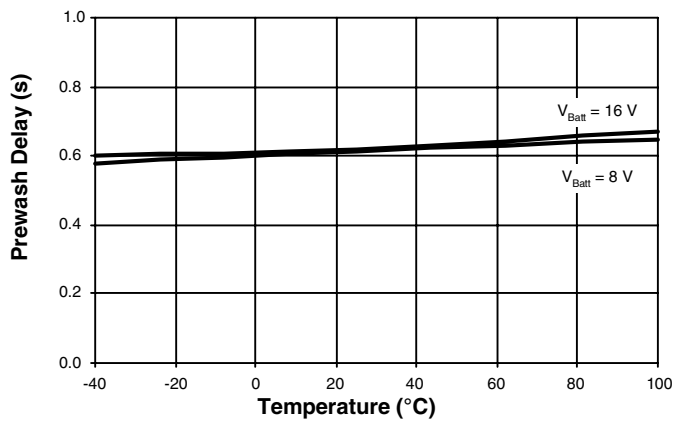
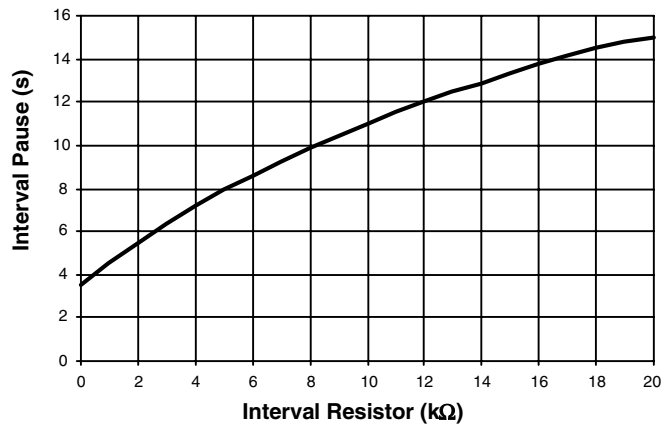

Figure 6. Prewash Time = f (T);  $C_t = 22 \mu\text{F}$

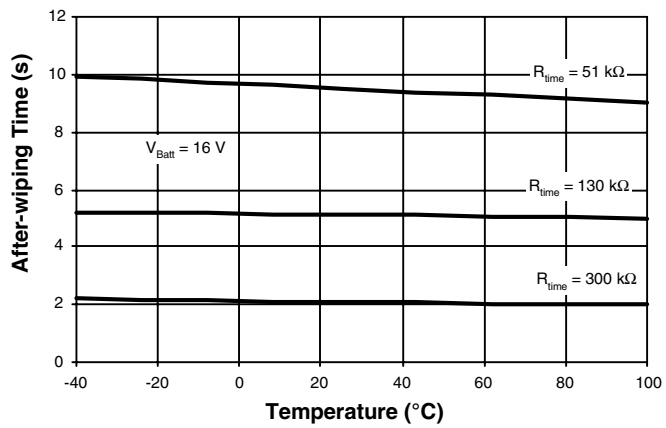



**Figure 7.** Interval Pause =  $f(R_{INT})$ ;  $C_t = 22 \mu\text{F}$



**Figure 8.** After-wiping Time =  $f(T)$ ;  $C_t = 22 \mu\text{F}$ ;  $V_{Batt} = 16 \text{ V}$



### Ordering Information

Extended Type Number	Package	Remarks
U641B	DIP8	–
U641B-FP	SO8	–

### Package Information

#### Package DIP8

Dimensions in mm

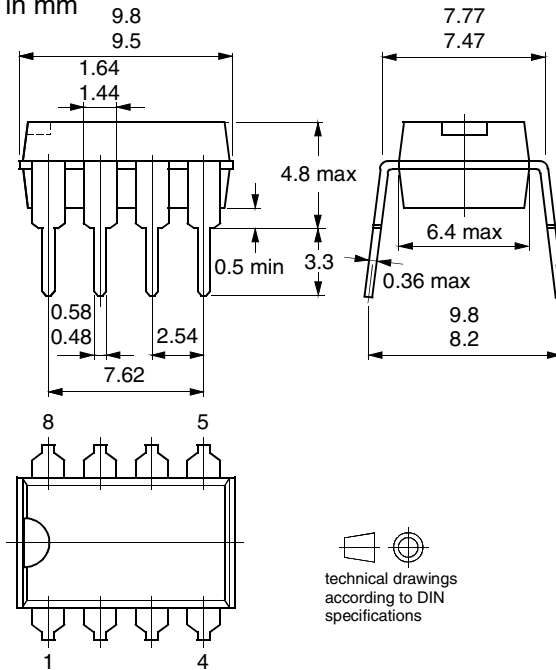

#### Package SO8

Dimensions in mm

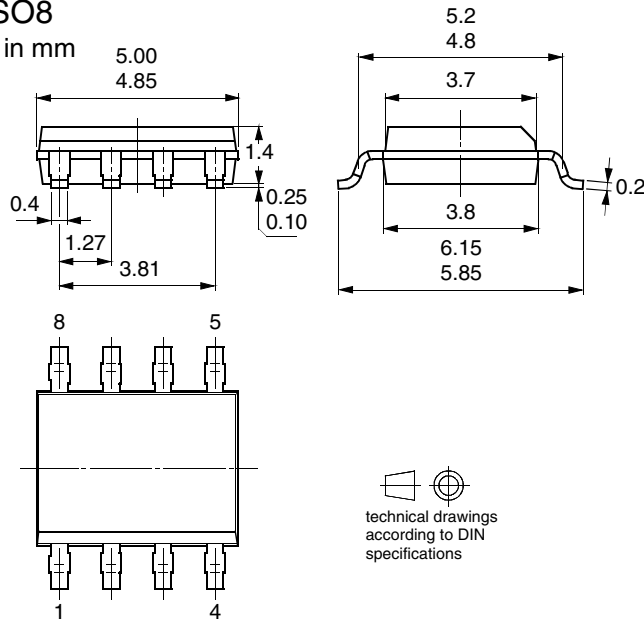



## Atmel Corporation

2325 Orchard Parkway  
San Jose, CA 95131, USA  
Tel: 1(408) 441-0311  
Fax: 1(408) 487-2600

## Regional Headquarters

### Europe

Atmel Sarl  
Route des Arsenalux 41  
Case Postale 80  
CH-1705 Fribourg  
Switzerland  
Tel: (41) 26-426-5555  
Fax: (41) 26-426-5500

### Asia

Room 1219  
Chinachem Golden Plaza  
77 Mody Road Tsimshatsui  
East Kowloon  
Hong Kong  
Tel: (852) 2721-9778  
Fax: (852) 2722-1369

### Japan

9F, Tonetsu Shinkawa Bldg.  
1-24-8 Shinkawa  
Chuo-ku, Tokyo 104-0033  
Japan  
Tel: (81) 3-3523-3551  
Fax: (81) 3-3523-7581

## Atmel Operations

### Memory

2325 Orchard Parkway  
San Jose, CA 95131, USA  
Tel: 1(408) 441-0311  
Fax: 1(408) 436-4314

### Microcontrollers

2325 Orchard Parkway  
San Jose, CA 95131, USA  
Tel: 1(408) 441-0311  
Fax: 1(408) 436-4314

La Chantrerie  
BP 70602  
44306 Nantes Cedex 3, France  
Tel: (33) 2-40-18-18-18  
Fax: (33) 2-40-18-19-60

### ASIC/ASSP/Smart Cards

Zone Industrielle  
13106 Rousset Cedex, France  
Tel: (33) 4-42-53-60-00  
Fax: (33) 4-42-53-60-01

1150 East Cheyenne Mtn. Blvd.  
Colorado Springs, CO 80906, USA  
Tel: 1(719) 576-3300  
Fax: 1(719) 540-1759

Scottish Enterprise Technology Park  
Maxwell Building  
East Kilbride G75 0QR, Scotland  
Tel: (44) 1355-803-000  
Fax: (44) 1355-242-743

### RF/Automotive

Theresienstrasse 2  
Postfach 3535  
74025 Heilbronn, Germany  
Tel: (49) 71-31-67-0  
Fax: (49) 71-31-67-2340

1150 East Cheyenne Mtn. Blvd.  
Colorado Springs, CO 80906, USA  
Tel: 1(719) 576-3300  
Fax: 1(719) 540-1759

### Biometrics/Imaging/Hi-Rel MPU/ High Speed Converters/RF Datacom

Avenue de Rochepleine  
BP 123  
38521 Saint-Egreve Cedex, France  
Tel: (33) 4-76-58-30-00  
Fax: (33) 4-76-58-34-80

---

### Literature Requests

[www.atmel.com/literature](http://www.atmel.com/literature)

**Disclaimer:** Atmel Corporation makes no warranty for the use of its products, other than those expressly contained in the Company's standard warranty which is detailed in Atmel's Terms and Conditions located on the Company's web site. The Company assumes no responsibility for any errors which may appear in this document, reserves the right to change devices or specifications detailed herein at any time without notice, and does not make any commitment to update the information contained herein. No licenses to patents or other intellectual property of Atmel are granted by the Company in connection with the sale of Atmel products, expressly or by implication. Atmel's products are not authorized for use as critical components in life support devices or systems.

© Atmel Corporation 2003. All rights reserved.

Atmel® and combinations thereof are the registered trademarks of Atmel Corporation or its subsidiaries.

Other terms and product names may be the trademarks of others.



Printed on recycled paper.