

## 阅读申明

- 1.本站收集的数据手册和产品资料都来自互联网，版权归原作者所有。如读者和版权方有任何异议请及时告之，我们将妥善解决。
- 2.本站提供的中文数据手册是英文数据手册的中文翻译，其目的是协助用户阅读，该译文无法自动跟随原稿更新，同时也可能存在翻译上的不当。建议读者以英文原稿为参考以便获得更精准的信息。
- 3.本站提供的产品资料，来自厂商的技术支持或者使用者的心得体会等，其内容可能存在描述上的差异，建议读者做出适当判断。
- 4.如需与我们联系，请发邮件到marketing@iczoom.com，主题请标有“数据手册”字样。

## Read Statement

1. The datasheets and other product information on the site are all from network reference or other public materials, and the copyright belongs to the original author and original published source. If readers and copyright owners have any objections, please contact us and we will deal with it in a timely manner.
2. The Chinese datasheets provided on the website is a Chinese translation of the English datasheets. Its purpose is for reader's learning exchange only and do not involve commercial purposes. The translation cannot be automatically updated with the original manuscript, and there may also be improper translations. Readers are advised to use the English manuscript as a reference for more accurate information.
3. All product information provided on the website refer to solutions from manufacturers' technical support or users the contents may have differences in description, and readers are advised to take the original article as the standard.
4. If you have any questions, please contact us at marketing@iczoom.com and mark the subject with "Datasheets" .

## General Description

The AS1124 is a single-chip, highly integrated CMOS solution for Power over Ethernet (PoE). Applications include Voice over IP (VoIP) Phones, Wireless LAN Access Point, Security and Web Cameras, Analog Telephone Adapters (ATA) and Point of Sales Terminals.

The AS1124 provides the functions required for power over Ethernet PD applications.

By using high-volume standard CMOS technology, Akros enables its customers to bring to market higher performance PoE devices with low cost and a small footprint.

The AS1124 integrates rectification and protection circuitry, a PD controller, and a DC-DC converter. This high level of integration provides faster response to surge events and limits stray surge current from passing through sensitive circuits, such as the Ethernet PHY device. The device is designed to provide a safe low impedance discharge paths directly back to the earth ground, resulting in superior reliability and circuit protection.

The AS1124 also supports higher power requirements. The device provides an extended classification scheme that allows for higher classes as power requirements cross above IEEE® Std. 802.3af-2003 limits.

## Features

The AS1124 is fully integrated and architected at a system level to provide the following features:

- Fully supports IEEE® Std. 802.3af-2003 and supports pre-standard IEEE® Std. 802.3at-2006 power requirements
- Meets IEC 61000-4-2/3/4/5/6 requirements for electric discharge
- Meets IEC 60950 overvoltage protection
- Integrated rectification and cable discharge protection
- Integrated DC-DC converter provides exceptional EMI performance
- Programmable DC current limit up to 800 mA
- Supports “two finger” classification for pre-standard IEEE® Std. 802.3at-2006 higher power PD applications
- Provides seamless support for local power
- Over temperature protection
- 5x5 mm QFN Package, RoHS Compliant

## Typical Applications

- Voice over IP (VoIP) phones
- Wireless LAN Access Points
- Pan, Tilt and Zoom, security and Web Cameras
- Analog Telephone Adapters (ATA)
- Point of Sale (PoS) Terminal

## Example Application Diagram

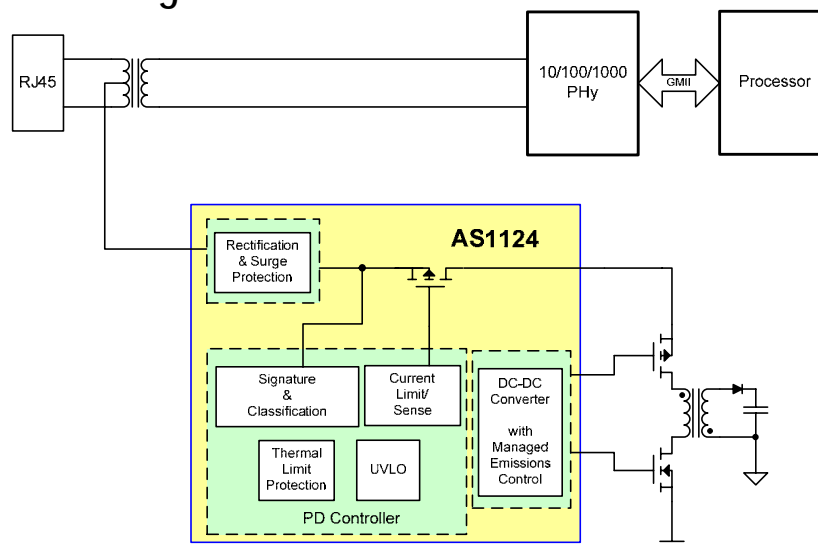
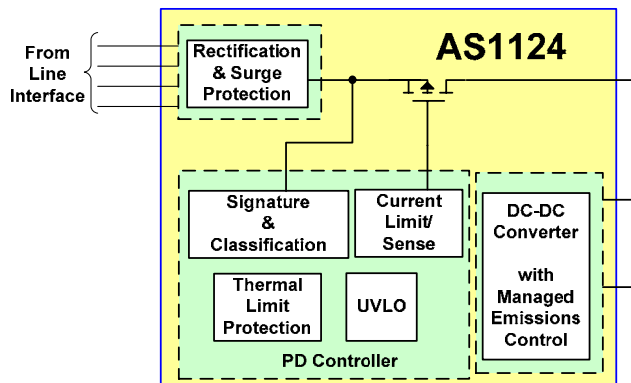

Figure 1: Typical Application Diagram for Gigabit Ethernet based PD (Flyback converter)



**Figure 1: Top-Level Block Diagram of the AS1124**

## Description

The AS1124 is a fully integrated PD that provides functions required for Power over Ethernet (PoE) applications and is scalable to support higher power applications over 2 pairs of CAT5e/6 cables. The optimized architecture of the AS1124 reduces external component cost in a small footprint package while providing high performance. The AS1124 provides:

## PD Control

The AS1124 PD Control interface is designed to provide a fully compliant IEEE 802.3af and higher powered PD system, with programmable support for the standard PD control functions. The PD Control provides the following major functions:

- Signals that it is a PD
- Determines the mode of operation of the AS1124, based on the IEEE 802.3af standard.
- Determines the mode of operation of the AS1124, based on the extended classification for higher power option.
- Manages power and thermal protection overrides.

## Modes of Operation

The AS1124 has four modes of operation:

1. Signature Detection - The PD signature is detected by the AS1124 to allow classification.
2. Classification - The PD signature is classified, to determine the power requirements of the PD.
3. Normal Operation - The PD is supplied the proper power by the AS1124.

4. Disable - PSE voltage is below normal and the power to the PD is off.

As the supply voltage from the PSE increases from initial 0V, the part transitions through the modes of operation in this sequence:

Disable → Signature Detection → Classification → Normal Operation

If no PSE is present, the AS1124 remains in the disable mode and does not affect the Ethernet link.

## PD Control Power and Thermal Protections

The AS1124 provides the following features for PD Control Power and Thermal protection:

- Under Voltage Lockout (UVLO)—The UVLO circuitry detects conditions when the voltage is too low, and disconnects the power to protect the PD.
- Current Limit/Current Sense—senses the operating current via the sense resistor and regulates the gate voltage on the on-chip power MOSFET to minimize on-chip Power dissipation.
- Thermal Limit/Protection—the AS1124 provides thermal protection for the IC by monitoring die temperatures and reducing current, or disconnecting power as appropriate.

## DC-DC Conversion

The integrated DC-DC converter operates from a switched input voltage and includes soft-start and current limiting. After the input power and enable signals are asserted, the DC-DC controller starts up. The converter provides control signals to external MOSFET switches and uses an external sense resistor to sense the transformer primary current.

As part of full system level solution for EMI, Akros has focused significant effort in reducing switching noise in the integrated power converters through unique techniques of balancing the signaling of the FET drivers and reducing ground bounce by minimizing the dV/dt switching noise.

The DC-DC architecture is a current mode converter which can be configured with external component changes for either flyback, forward or buck topologies. Both non-isolated and isolated switching technologies are supported. The PWM switching signal is controlled for low radiated and conducted emissions.

## For More Information

Contact us at [marcom@akrossilicon.com](mailto:marcom@akrossilicon.com), or Akros Silicon,

6399 San Ignacio Ave, Suite 250, San Jose, CA 95119