

阅读申明

- 1.本站收集的数据手册和产品资料都来自互联网，版权归原作者所有。如读者和版权方有任何异议请及时告之，我们将妥善解决。
- 2.本站提供的中文数据手册是英文数据手册的中文翻译，其目的是协助用户阅读，该译文无法自动跟随原稿更新，同时也可能存在翻译上的不当。建议读者以英文原稿为参考以便获得更精准的信息。
- 3.本站提供的产品资料，来自厂商的技术支持或者使用者的心得体会等，其内容可能存在描述上的差异，建议读者做出适当判断。
- 4.如需与我们联系，请发邮件到marketing@iczoom.com，主题请标有“数据手册”字样。

Read Statement

1. The datasheets and other product information on the site are all from network reference or other public materials, and the copyright belongs to the original author and original published source. If readers and copyright owners have any objections, please contact us and we will deal with it in a timely manner.
2. The Chinese datasheets provided on the website is a Chinese translation of the English datasheets. Its purpose is for reader's learning exchange only and do not involve commercial purposes. The translation cannot be automatically updated with the original manuscript, and there may also be improper translations. Readers are advised to use the English manuscript as a reference for more accurate information.
3. All product information provided on the website refer to solutions from manufacturers' technical support or users the contents may have differences in description, and readers are advised to take the original article as the standard.
4. If you have any questions, please contact us at marketing@iczoom.com and mark the subject with "Datasheets" .

SUPPLY VOLTAGE MONITOR

ISSUE 2 – JANUARY 2003

ZSM530

DEVICE DESCRIPTION

The ZSM530 is a three terminal under voltage monitor circuit for use in microprocessor systems. The threshold voltage of the device has been set to 4.3 volts making it ideal for 5 volt circuits.

Included in the device is a precise voltage reference and a comparator with built in hysteresis to prevent erratic operation. The ZSM530 features an open collector output capable of sinking at least 10mA which only requires a single external resistor to interface to following circuits.

Operation of the device is guaranteed from one volt upwards, from this level to the device threshold voltage the output is held low providing a power on reset function. Should the supply voltage, once established, at any time drop below the threshold level then the output again will pull low.

The device is available in a TO92 package for through hole applications as well as SOT223 for surface mount requirements.

FEATURES

- SOT223 and TO92 packages
- Power on reset generator
- Automatic reset generation
- Low standby current
- Guaranteed operation from 1 volt
- Wide supply voltage range
- Internal clamp diode to discharge delay capacitor
- 4.3 volt threshold for 5 volt logic
- 20mV hysteresis prevents erratic operation

APPLICATIONS

- Microprocessor systems
- Computers
- Computer peripherals
- Instrumentation
- Automotive
- Battery powered equipment

SCHEMATIC DIAGRAM

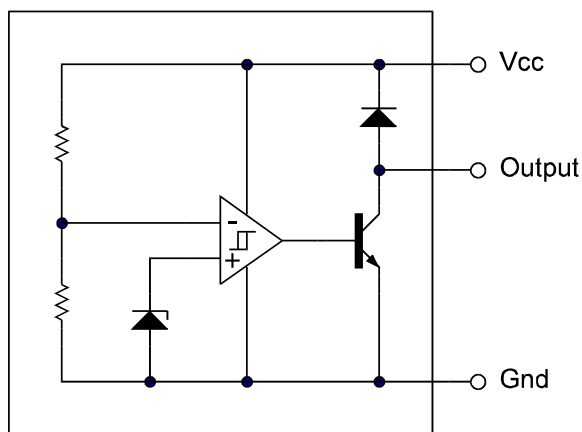

ZSM530

ABSOLUTE MAXIMUM RATING

| | | | |
|--------------------------------|--------------------|--------------------------|------------|
| Input Supply Voltage | -1 to 10V | Power Dissipation | |
| Offstate Output Voltage | 10V | TO92 | 780mW |
| Onstate Output | | SOT223 | 2W(Note 2) |
| Sink Current(Note 1) | Internally limited | | |
| Clamp Diode | | | |
| Forward Current(Note 1) | 100mA | | |
| Operating Junction Temperature | 150°C | | |
| Operating Temperature | -40 to 85°C | | |
| Storage Temperature | -55 to 150°C | | |

TEST CONDITIONS

($T_{amb}=25^{\circ}\text{C}$ for typical values, $T_{amb}=-40$ to 85°C for min/max values (Note3))

COMPARATOR

| PARAMETER | SYMBOL | MIN | TYP. | MAX. | UNITS |
|---|----------|------|------|------|-------|
| Threshold Voltage High state output (V_{cc} increasing) | V_{IH} | 4.2 | 4.31 | 4.4 | V |
| Threshold Voltage Low state output (V_{cc} decreasing) | V_{IL} | 4.2 | 4.29 | 4.4 | V |
| Hysteresis | V_H | 0.01 | 0.02 | 0.05 | V |

OUTPUT

| | | | | | |
|---|------------|-----|------|------|---------------|
| Output sink saturation: ($V_{cc}=3.8\text{V}$, $I_{sink}=8.0\text{mA}$) | V_{OL} | | 0.46 | 1.0 | V |
| ($V_{cc}=3.8\text{V}$, $I_{sink}=2.0\text{mA}$) | | | 0.15 | 0.4 | V |
| ($V_{cc}=1.0\text{V}$, $I_{sink}=0.1\text{mA}$) | | | | 0.25 | V |
| Onstate output sink current (V_{cc} , Output=3.8V) | I_{sink} | 10 | 27 | 60 | mA |
| Offstate output leakage current (V_{cc} , Output=5V) | I_{oh} | | 0.02 | 0.5 | μA |
| Clamp diode forward voltage ($I_f=10\text{mA}$) | V_f | 0.6 | 1.2 | 1.5 | V |
| Propagation delay (V_{in} 5V to 3.8V, $R_I=10\text{k}$, $T_{amb}=25^{\circ}\text{C}$) | T_d | | 2 | | μs |

TOTAL DEVICE

| | | | | | |
|--|----------|------------|-----|-----|---------------|
| Operating input voltage range | V_{cc} | 1.0 to 6.5 | | | V |
| Quiescent input current ($V_{cc}=5\text{V}$) | I_q | | 175 | 260 | μA |

Note:

1. Maximum package power dissipation must be observed.
2. Maximum power dissipation for the SOT223 package is calculated assuming that the device is mounted on a PCB measuring 2 inches square.
3. Low duty cycle pulse techniques are used during test to maintain junction temperatures as close to ambient as possible.

ZSM530

TYPICAL CHARACTERISTICS

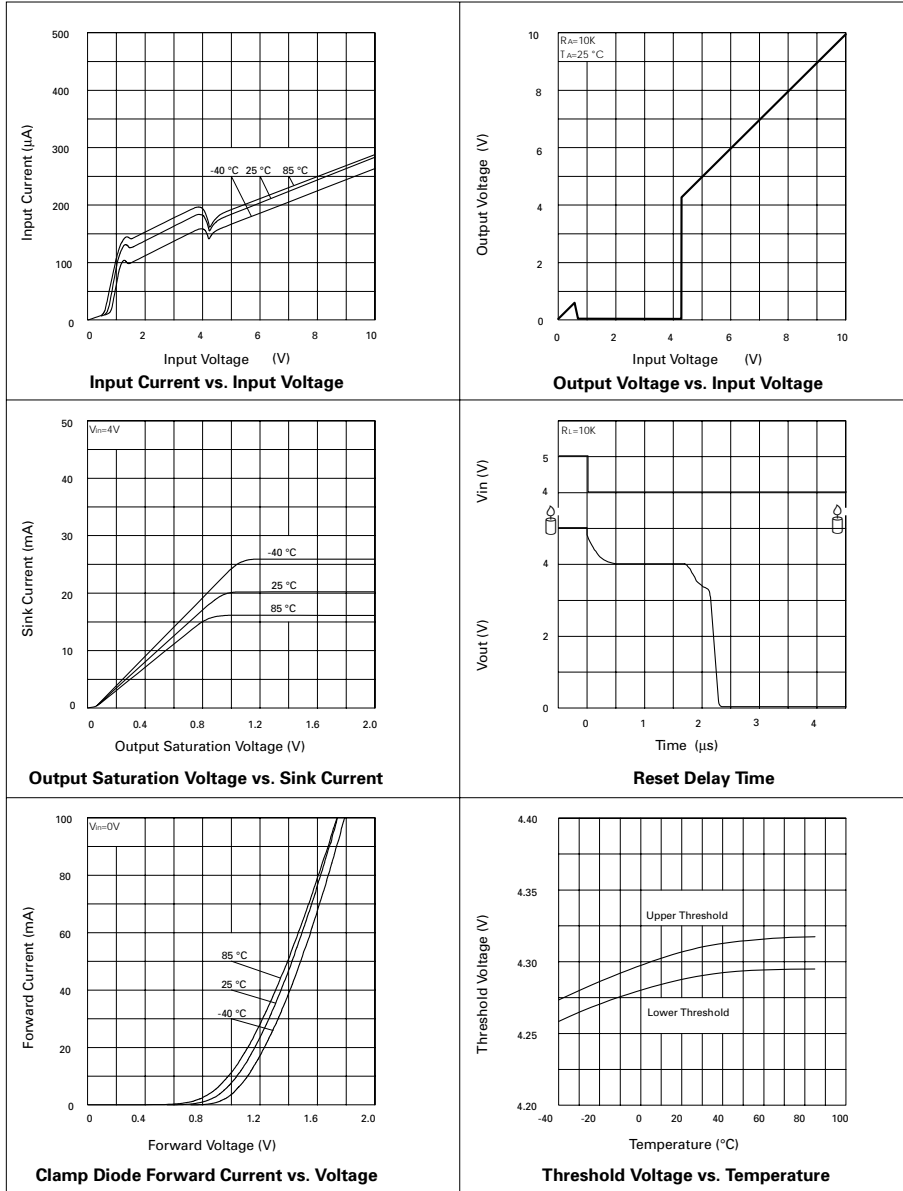

ZSM530

TIMING DIAGRAM

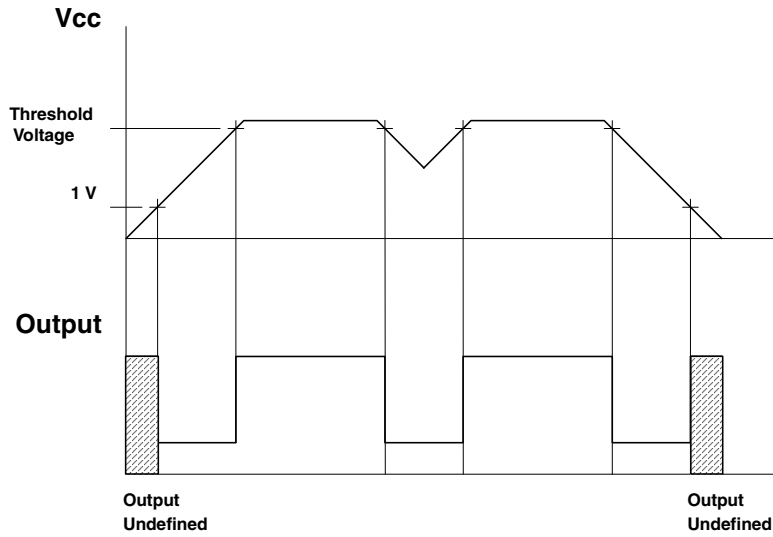

APPLICATION CIRCUIT

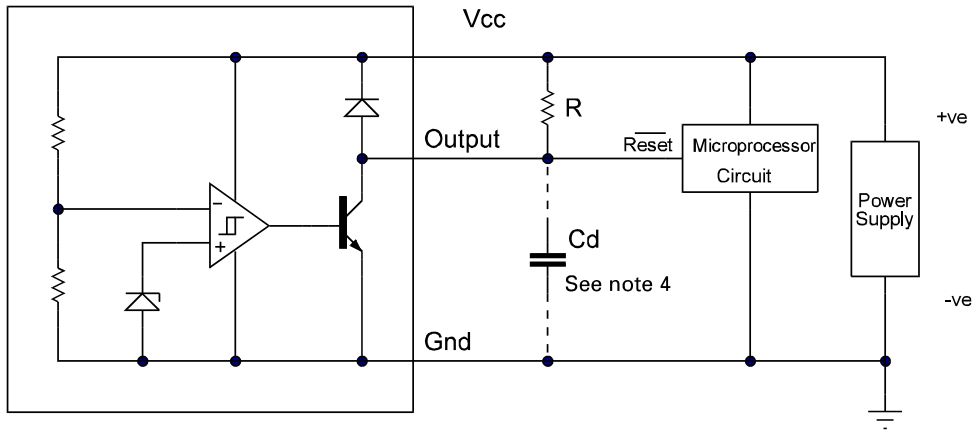

Note 4: A time delayed reset can be accomplished with the additional Cd.

$$T_{DY} = RCd \ln \left(\frac{1}{1 - \frac{V_{TH(mpu)}}{V_{in}}} \right)$$

T_{DY} = Time (Seconds)
 V_{TH} = Microprocessor Reset Threshold
 V_{in} = Power Supply Voltage

ZSM530

CONNECTION DIAGRAMS

SOT223 Package Suffix – G

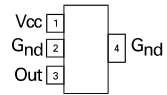

*Top View –
Pin 4 floating or connected to pin 2*

TO92 Package Suffix – C

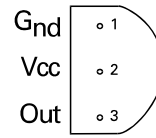

Bottom View

ORDERING INFORMATION

| Part Number | Package | Part Mark |
|-------------|---------|-----------|
| ZSM530G | SOT223 | ZSM530 |
| ZSM530C | TO92 | ZSM530 |