

阅读申明

- 1.本站收集的数据手册和产品资料都来自互联网，版权归原作者所有。如读者和版权方有任何异议请及时告之，我们将妥善解决。
- 2.本站提供的中文数据手册是英文数据手册的中文翻译，其目的是协助用户阅读，该译文无法自动跟随原稿更新，同时也可能存在翻译上的不当。建议读者以英文原稿为参考以便获得更精准的信息。
- 3.本站提供的产品资料，来自厂商的技术支持或者使用者的心得体会等，其内容可能存在描述上的差异，建议读者做出适当判断。
- 4.如需与我们联系，请发邮件到marketing@iczoom.com，主题请标有“数据手册”字样。

Read Statement

1. The datasheets and other product information on the site are all from network reference or other public materials, and the copyright belongs to the original author and original published source. If readers and copyright owners have any objections, please contact us and we will deal with it in a timely manner.
2. The Chinese datasheets provided on the website is a Chinese translation of the English datasheets. Its purpose is for reader's learning exchange only and do not involve commercial purposes. The translation cannot be automatically updated with the original manuscript, and there may also be improper translations. Readers are advised to use the English manuscript as a reference for more accurate information.
3. All product information provided on the website refer to solutions from manufacturers' technical support or users the contents may have differences in description, and readers are advised to take the original article as the standard.
4. If you have any questions, please contact us at marketing@iczoom.com and mark the subject with "Datasheets" .

W83L761G

**WINBOND
H/W MONITORING IC**

W83L761G Preliminary



Table of Contents-

1.	GENERAL DESCRIPTION	1
2.	FEATURES	1
3.	KEY SPECIFICATIONS	2
4.	BLOCK DIAGRAM	2
5.	PIN CONFIGURATION	3
6.	PIN DESCRIPTION	3
7.	FUNCTIONAL DESCRIPTION.....	4
	7.1 General Description	4
	7.2 Access Interface	4
	7.3 Temperature Measurement Machine	5
8.	CONTROL AND STATUS REGISTER	6
	8.1 Configuration Register (Write Only).....	6
	8.2 Temperature Register Return Format (Read at Normal Mode, Read Only)	6
	8.3 Manufacturer's / Device ID Register Return Format (Read at Power-Down Mode, Read Only) ..	6
9.	ELECTRICAL CHARACTERISTIC	7
	9.1 Absolute Maximum Ratings	7
	9.2 DC Characteristics	7
	9.3 AC Characteristics	7
10.	THE TOP MARKING	9
11.	PACKAGE SPECIFICATION	10
12.	APPLICATION CIRCUITS	11

W83L761G Preliminary



1. GENERAL DESCRIPTION

W83L761G is a hardware monitoring IC with high temperature accuracy, low-power consumption, and SPI (Serial Peripheral Interface) interface. W83L761G has an on-chip thermal sensor and an 8–bits ADC (Analog to Digital Converter) to convert the monitored temperature values. The temperature resolution and accuracy is 0.5 °C and ± 3 °C, respectively, and the operation temperature is from -20°C to + 120°C.

W83L761G is available in SOT23-5 package. The working voltage ranges from 3V to 5.5V. Small package dimension, 2.9mm × 2.8mm (including the pin length), low power consumption and simple SPI interface make W83L761G easy to use in every application filed.

2. FEATURES

Monitoring Items - Temperature

- Measure the temperature with high accuracy.
- One on-chip thermal sensor.

General

- Interface: SPI control.
- 3V~5.5V V_{CC} operation.

Package

- 5-pin SOT-23-5.
- Dimension: 2.9mm × 2.8mm.

W83L761G Preliminary



3. KEY SPECIFICATIONS

- Monitoring temperature range and accuracy:
 -20 °C ~ +120 °C ± 3°C(@70°C)
- Supply voltage 3V~5.5V
- Operating supply current 3V: 2 mA typ.
 5V: 2.8 mA typ.
- Power down supply current 3V: 300 uA typ.
 5V: 900 uA typ.
- ADC resolution 8 Bits

4. BLOCK DIAGRAM

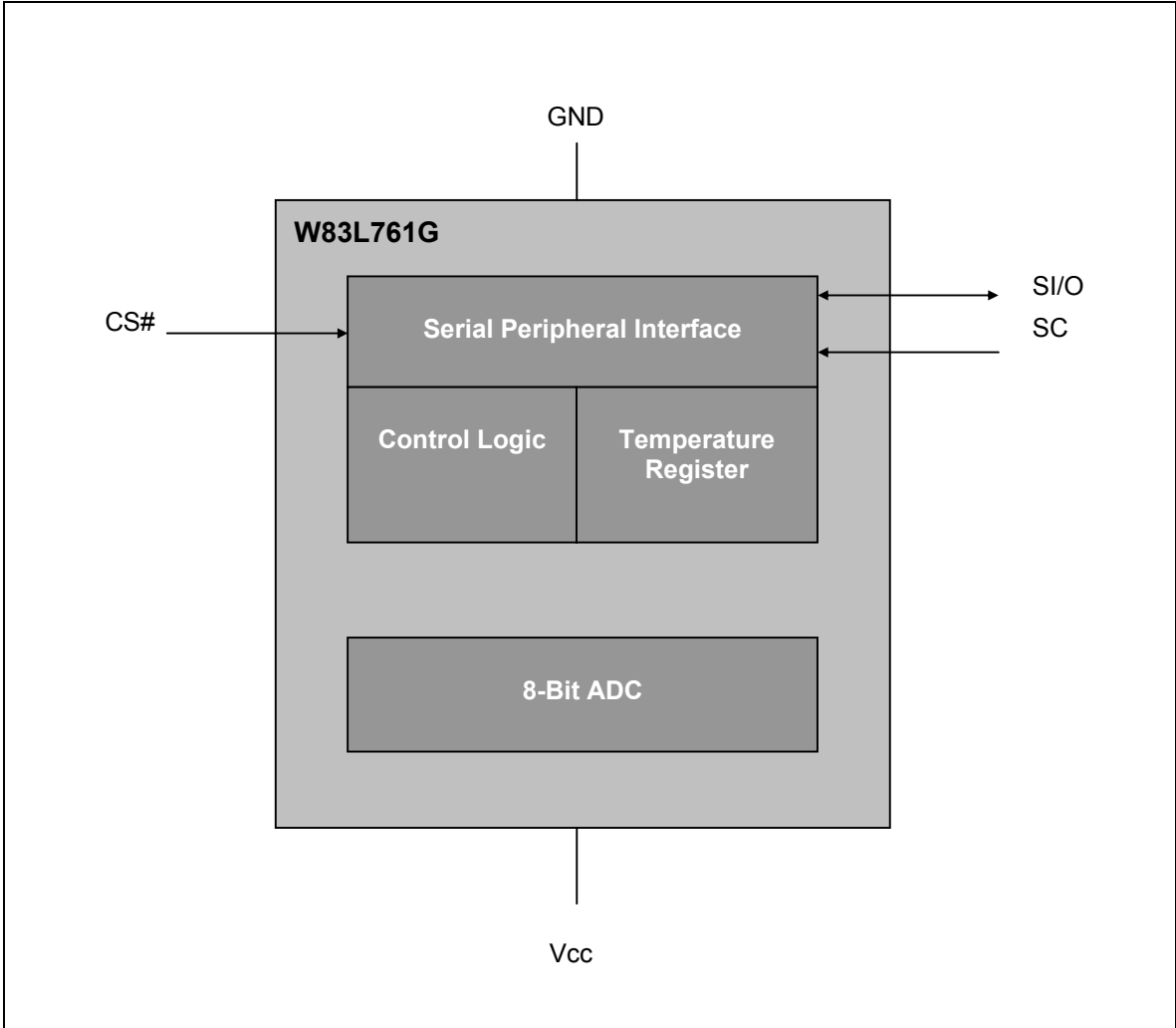

W83L761G Preliminary



5. PIN CONFIGURATION

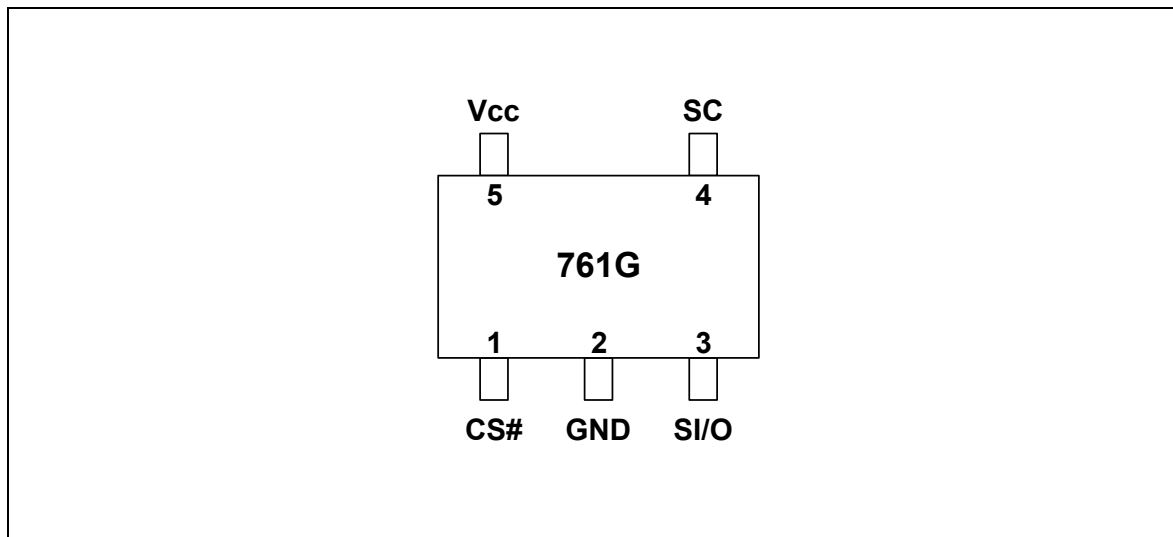

6. PIN DESCRIPTION

I/O _{12ts}	TTL level and schmitt trigger with 12 mA source-sink capability
IN _{ts}	TTL level input pin and schmitt trigger

PIN NAME	NO	PIN TYPE	DESCRIPTION
CS#	1	IN _{ts}	Chip select input from Controller.
GND	2	-	System ground.
S/O	3	I/O _{12ts}	Slave input/output – Serial bus bidirectional data line – from and to Controller.
SC	4	IN _{ts}	Slave clock from controller.
V _{CC}	5	Power	3.0V ~ 5.5 V power supply. Bypass with 0.1 μF ceramic capacitors.

W83L761G Preliminary



7. FUNCTIONAL DESCRIPTION

7.1 General Description

W83L761G is a hardware monitoring IC with high temperature accuracy. W83L761G will be accessed by SPI (Serial Peripheral Interface) interface. An 8-bit analog-to-digital converter (ADC) is built inside W83L761G for monitored temperature converting. Shutdown mode is enabled by writing XXFF to W83L761G, and will always output 800Fh.

7.2 Access Interface

W83L761G acts as a slave device on SPI compatible bus. CS# acts as the trigger of the W83L761G. W83L761G would not response to the serial interface bus unless CS# acts low. SC is the serial clock issued by the host. The data is received at the rising edge of the SC, and transmitted at the falling edge of the SC.

There are three kinds of access types. Figure 1 shows the first access type, continuous reading 8-bit frame from 761G. Here, "continuous" means the CS# does not de-asserted while reading out data. At the end of last bit, host must output high on CS# to terminate the cycle. This access type is used to readout W83L761G 8-bit temperature.

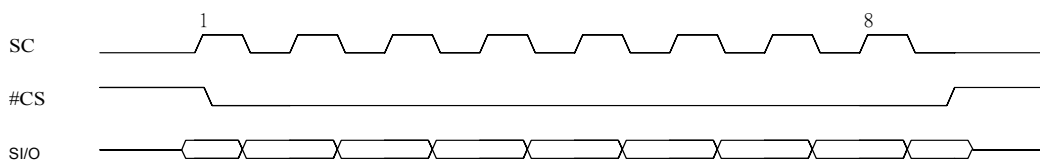

Figure 1 Continuous Reading 8 bit frame

The second access type is continuous reading 16-bit frame from W83L761G, and is illustrated in figure 2. After first byte readout, host will not de-assert CS#, but will continue to send SC until next byte is read out and then de-assert CS#.

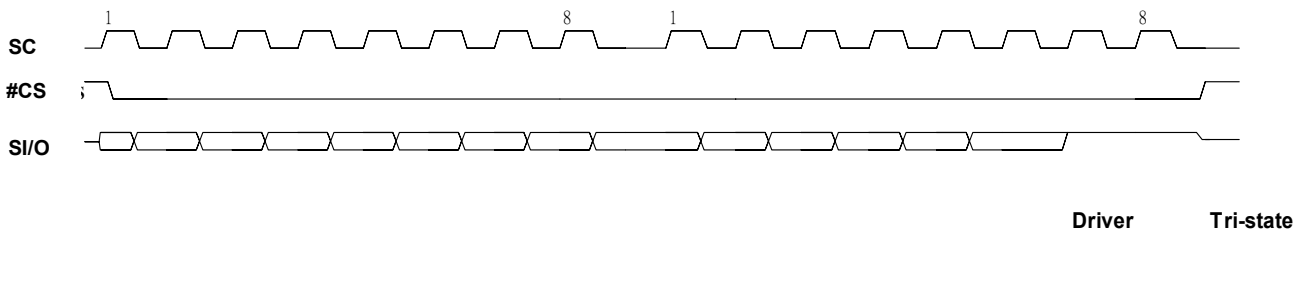

Figure 2 Continuous Reading 16 bit frame

W83L761G Preliminary



The last access type, used for host to issue shut-down command, is shown in figure 3. After reading 2 bytes temperature from W83L761G, host continues to send clock and 2 more bytes command. During all 4 bytes, the CS# never de-asserts.

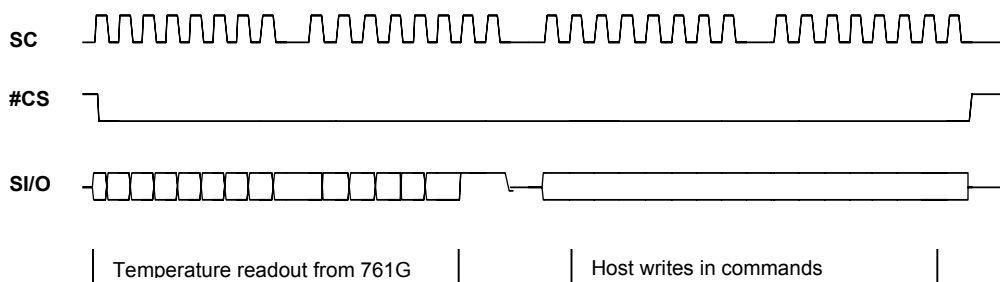

Figure 3 Shutdown Control

7.3 Temperature Measurement Machine

W83L761G temperature data format is 8-bit/10-bit complement. The 8-bit/10-bit temperature data can be obtained by reading the temperature register return format (section 8.2). The format of temperature data is shown in Table 1.

TEMPERATURE	8-BIT DIGITAL OUTPUT		10-BIT DIGITAL OUTPUT	
	8-BIT BINARY	8-BIT HEX	10-BIT BINARY	10-BIT HEX
+125°C	0011,1110	3Eh	00,1111,1010	0FAh
+25°C	0000,1100	0Ch	00,0011,0010	032h
+1°C	0000,0000	00h	00,0000,0010	002h
+0.5°C	-	-	00,0000,0001	001h
+0°C	0000,0000	00h	00,0000,0000	000h
-0.5°C	-	-	11,1111,1111	3FFh
-1°C	1111,1111	FFh	11,1111,1110	3FFh
-25°C	1111,0011	F3h	11,1100,1110	3CEh
-55°C	1110,0100	E4h	11,1001,0010	392h

Table 1

W83L761G Preliminary



8. CONTROL AND STATUS REGISTER

8.1 Configuration Register (Write Only)

(Selects shutdown or continuous conversion mode)

D15	D14	D13	D12	D11	D10	D9	D8
X	X	X	X	X	X	X	X

D7	D6	D5	D4	D3	D2	D1	D0
Command							

D15-D0 set to XX FF hexes enables shutdown mode.

D15-D0 set to XX 00 hexes enables continuous conversion mode.

Note: Setting D15-D0 to any other values may place the W83L761G into a manufacturer's test mode. These test modes are used for Winbond production testing only.

8.2 Temperature Register Return Format (Read at Normal Mode, Read Only)

D15	D14	D13	D12	D11	D10	D9	D8
MSB	Bit8	Bit7	Bit6	Bit5	Bit4	Bit3	Bit2

D7	D6	D5	D4	D3	D2	D1	D0
Bit1	Bit0	0	0	0	0	1	1

D15-D6: Temperature data. One LSB=0.5 °C. Two's complement format

D5-D2: Logic 0 will be output on S/I/O.

D1-D0: Logic 1 will be output on S/I/O.

8.3 Manufacturer's / Device ID Register Return Format (Read at Power-Down Mode, Read Only)

D15	D14	D13	D12	D11	D10	D9	D8
1	0	0	0	0	0	0	0

D7	D6	D5	D4	D3	D2	D1	D0
0	0	0	0	1	1	1	1

D15-D2: Manufacturer's / Device ID data. This register accessed whenever the W83L761G is in shutdown mode.

D1-D0: Logic 1 will be output on S/I/O.

W83L761G Preliminary



9. ELECTRICAL CHARACTERISTIC

9.1 Absolute Maximum Ratings

PARAMETER	RATING	UNIT
Power Supply Voltage	-0.5 to 7.0	V
Input Voltage	3 to 5.5	V
Operating Temperature	-20 to +125	° C
Storage Temperature	-50 to +150	° C

Note: Exposure to conditions beyond those listed under Absolute Maximum Ratings may adversely affect the life and reliability of the device.

9.2 DC Characteristics

(Ta = 0° C to 70° C, VDD = 3.3V ± 10%, VSS = 0V)

PARAMETER	SYM.	MIN.	TYP.	MAX.	UNIT	CONDITIONS
I/O _{12ts} – TTL level bi-directional pin with source-sink capability of 12 mA and schmitt-trigger level input						
Input Low Threshold Voltage	Vt-	0.5	0.8	1.1	V	VDD = 3.3 V
Input High Threshold Voltage	Vt+	1.6	2.0	2.4	V	VDD = 3.3 V
Hysteresis	VTH	0.5	1.2		V	VDD = 3.3 V
Output Low Voltage	VOL			0.4	V	IOL = 12 mA
Output High Voltage	VOH	2.4			V	IOH = - 12 mA
Input High Leakage	ILIH			+10	μA	VIN = VDD
Input Low Leakage	ILIL			-10	μA	VIN = 0V
IN _{ts} - TTL level Schmitt-triggered input pin						
Input Low Threshold Voltage	Vt-	0.5	0.8	1.1	V	VDD = 3.3 V
Input High Threshold Voltage	Vt+	1.6	2.0	2.4	V	VDD = 3.3 V
Hysteresis	VTH	0.5	1.2		V	VDD = 3.3 V
Input High Leakage	ILIH			+10	μA	VIN = VDD
Input Low Leakage	ILIL			-10	μA	VIN = 0 V

9.3 AC Characteristics

PARAMETER	SYMBOL	TYP.	UNITS
SC (Clock) Period	T1	0.16	μs
CS# to SC (Clock) High Set-Up Time	T2	100	ns
CS# to Data Out (SO) Delay	T3	70	ns
SC (Clock) Low to Data Out (SO) Delay	T4	70	ns
CS# High to Data Out (SO) TRI-STATE	T5	200	ns
SC and S/I/O Rise Time	TR	10	ns
SC and S/I/O Fall Time	TF	10	ns

Publication Release Date: April 18, 2005
Revision 1.0

W83L761G Preliminary



SC (Clock) High to Data in (SI) Hold Time	T6	50	ns
Data In (SI) Set-Up Time to SC (Clock) High	T7	30	ns

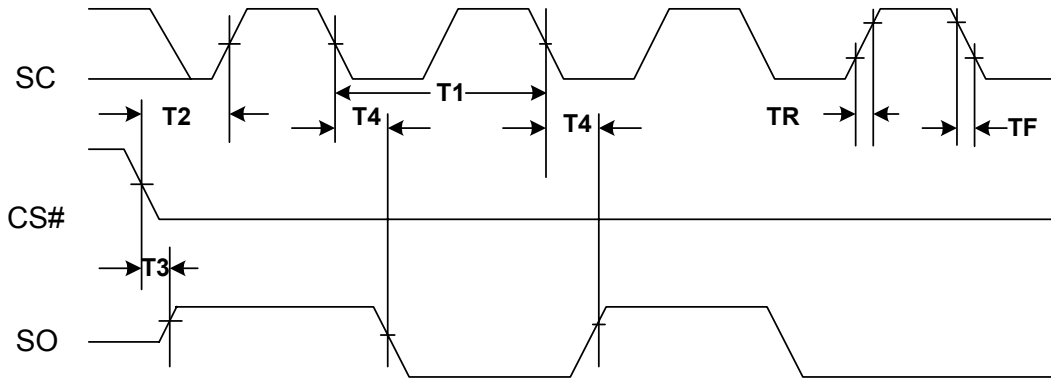

Data Output Timing Diagram

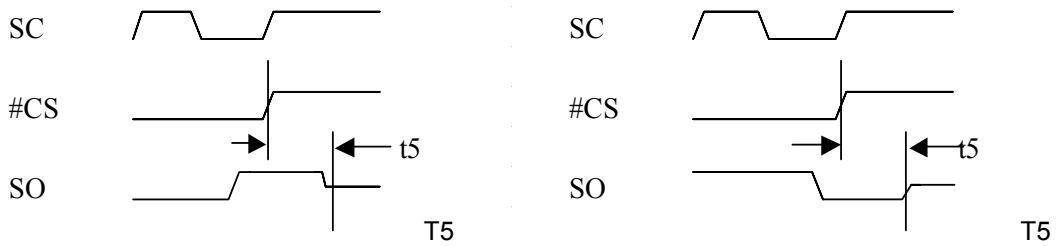

TRI-STATE Data Output Timing Diagram

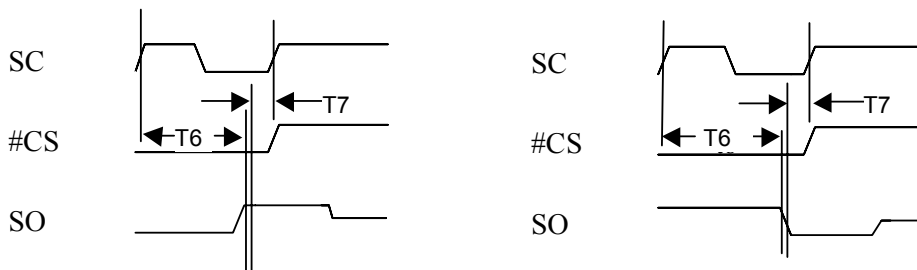

W83L761G Preliminary



Data Input Timing Diagram

10. THE TOP MARKING

The top marking of W83L761G



Left: Winbond logo

1st line: Winbond logo and the type number: W83L761G

2nd line: Tracking code 2 826978Y-61

3rd line: Tracking code 443 O B

443: packages made in '04, week 43

O: assembly house ID; A means ASE, S means SPIL, O means OSE

B: IC revision

W83L761G Preliminary



11. PACKAGE SPECIFICATION

SOT23-5

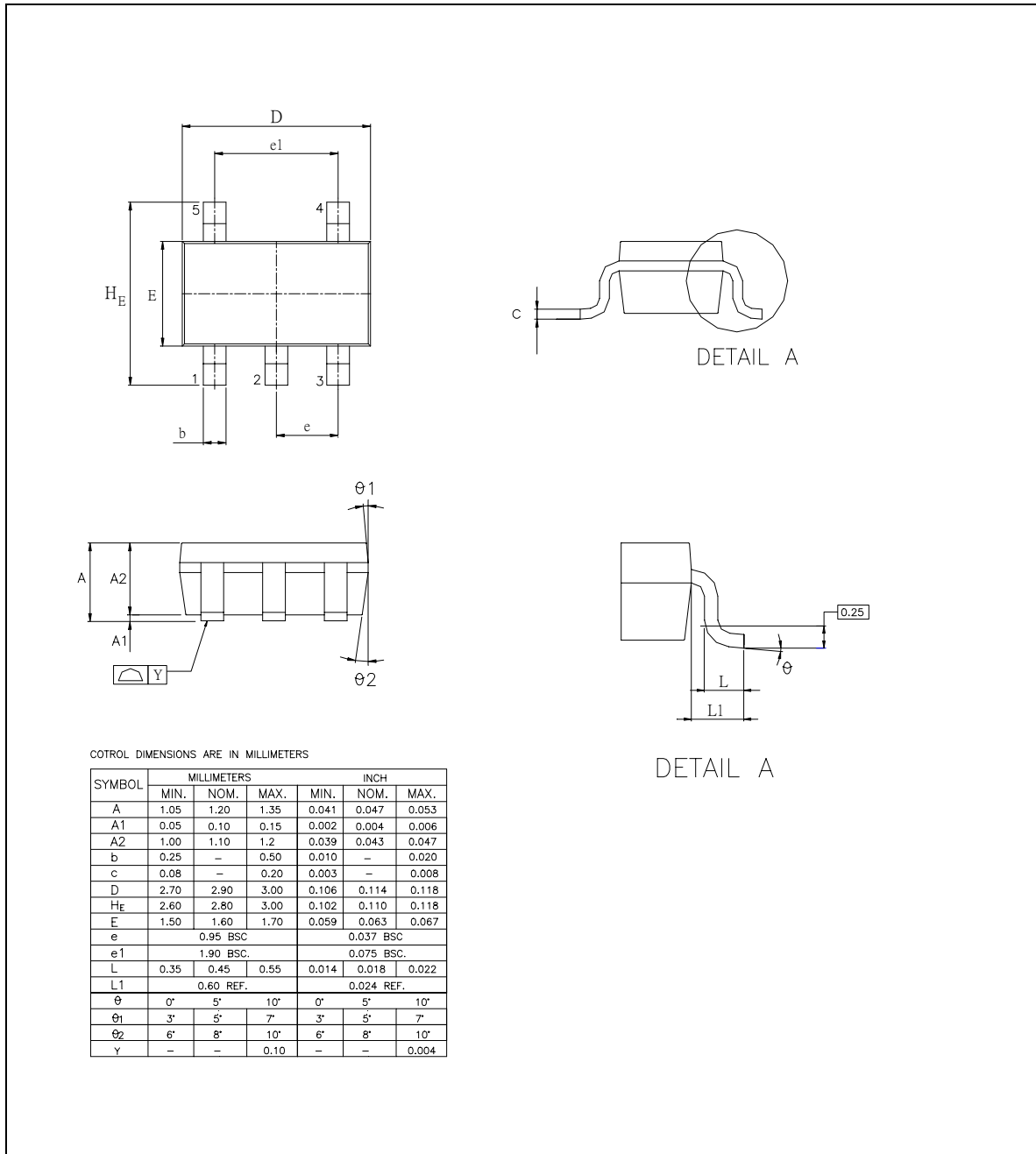

CONTROL DIMENSIONS ARE IN MILLIMETERS

SYMBOL	MILLIMETERS			INCH		
	MIN.	NOM.	MAX.	MIN.	NOM.	MAX.
A	1.05	1.20	1.35	0.041	0.047	0.053
A1	0.05	0.10	0.15	0.002	0.004	0.006
A2	1.00	1.10	1.2	0.039	0.043	0.047
b	0.25	-	0.50	0.010	-	0.020
c	0.08	-	0.20	0.003	-	0.008
D	2.70	2.90	3.00	0.106	0.114	0.118
HE	2.60	2.80	3.00	0.102	0.110	0.118
E	1.50	1.60	1.70	0.059	0.063	0.067
e	0.95 BSC.			0.037 BSC.		
e1	1.90 BSC.			0.075 BSC.		
L	0.35	0.45	0.55	0.014	0.018	0.022
L1	0.60 REF.			0.024 REF.		
θ	0°	5°	10°	0°	5°	10°
$\theta 1$	3°	5°	7°	3°	5°	7°
$\theta 2$	6°	8°	10°	6°	8°	10°
Y	-	-	0.10	-	-	0.004

12. APPLICATION CIRCUITS

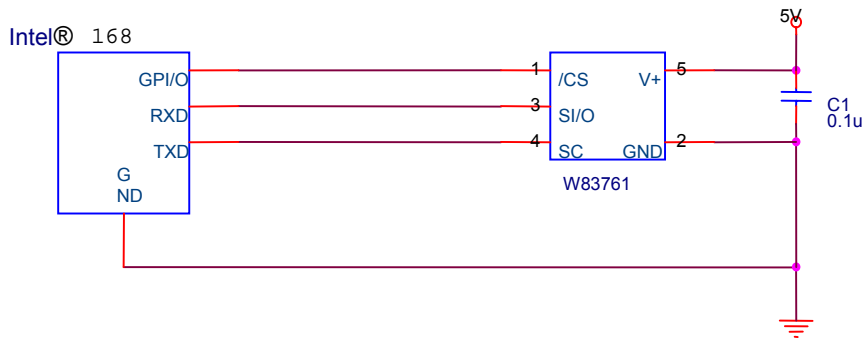
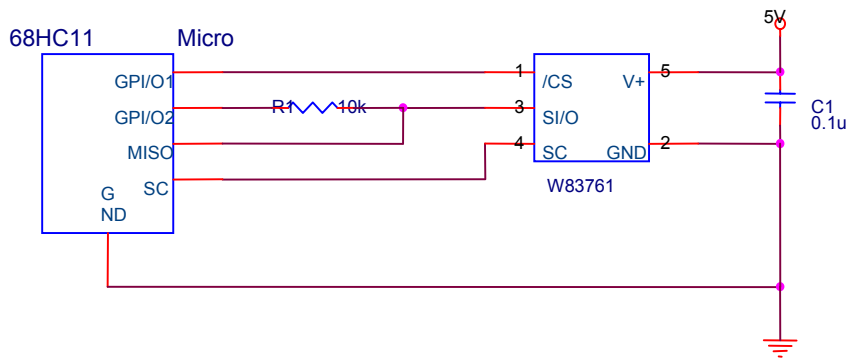

Title		
Winbond Hardware		
Size	Document	Rev
A	W83761 Application Circuit	0.2
Date: Monday, November 24, Sheet 1 of 1		

W83L761G Preliminary



REVISION HISTORY

VERSION	DATE	PAGE	DESCRIPTION
1.0	April 18, 2005	12	ADD Important Notice

Important Notice

Winbond products are not designed, intended, authorized or warranted for use as components in systems or equipment intended for surgical implantation, atomic energy control instruments, airplane or spaceship instruments, transportation instruments, traffic signal instruments, combustion control instruments, or for other applications intended to support or sustain life. Further more, Winbond products are not intended for applications wherein failure of Winbond products could result or lead to a situation wherein personal injury, death or severe property or environmental damage could occur.

Winbond customers using or selling these products for use in such applications do so at their own risk and agree to fully indemnify Winbond for any damages resulting from such improper use or sales.



Headquarters

No. 4, Creation Rd. III,
Science-Based Industrial Park,
Hsinchu, Taiwan
TEL: 886-3-5770066
FAX: 886-3-5665577
<http://www.winbond.com.tw/>

Taipei Office

9F, No.480, Rueiguang Rd.,
Neihu District, Taipei, 114,
Taiwan, R.O.C.
TEL: 886-2-8177-7168
FAX: 886-2-8751-3579

Winbond Electronics Corporation America

2727 North First Street, San Jose,
CA 95134, U.S.A.
TEL: 1-408-9436666
FAX: 1-408-5441798

Winbond Electronics Corporation Japan

7F Daini-ueno BLDG, 3-7-18
Shinyokohama Kohoku-ku,
Yokohama, 222-0033
TEL: 81-45-4781881
FAX: 81-45-4781800

Winbond Electronics (Shanghai) Ltd.

27F, 2299 Yan An W. Rd. Shanghai,
200336 China
TEL: 86-21-62365999
FAX: 86-21-62365998

Winbond Electronics (H.K.) Ltd.

Unit 9-15, 22F, Millennium City,
No. 378 Kwun Tong Rd.,
Kowloon, Hong Kong
TEL: 852-27513100
FAX: 852-27552064

*Please note that all data and specifications are subject to change without notice.
All the trade marks of products and companies mentioned in this data sheet belong to their respective owners.*