

## 阅读申明

- 1.本站收集的数据手册和产品资料都来自互联网，版权归原作者所有。如读者和版权方有任何异议请及时告之，我们将妥善解决。
- 2.本站提供的中文数据手册是英文数据手册的中文翻译，其目的是协助用户阅读，该译文无法自动跟随原稿更新，同时也可能存在翻译上的不当。建议读者以英文原稿为参考以便获得更精准的信息。
- 3.本站提供的产品资料，来自厂商的技术支持或者使用者的心得体会等，其内容可能存在描述上的差异，建议读者做出适当判断。
- 4.如需与我们联系，请发邮件到marketing@iczoom.com，主题请标有“数据手册”字样。

## Read Statement

1. The datasheets and other product information on the site are all from network reference or other public materials, and the copyright belongs to the original author and original published source. If readers and copyright owners have any objections, please contact us and we will deal with it in a timely manner.
2. The Chinese datasheets provided on the website is a Chinese translation of the English datasheets. Its purpose is for reader's learning exchange only and do not involve commercial purposes. The translation cannot be automatically updated with the original manuscript, and there may also be improper translations. Readers are advised to use the English manuscript as a reference for more accurate information.
3. All product information provided on the website refer to solutions from manufacturers' technical support or users the contents may have differences in description, and readers are advised to take the original article as the standard.
4. If you have any questions, please contact us at marketing@iczoom.com and mark the subject with "Datasheets" .

# Nais

## SLIM TYPE POWER RELAYS

# JR-RELAYS

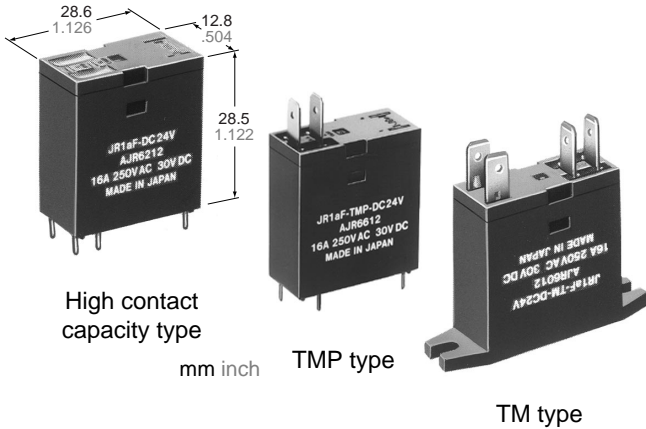

### FEATURES

- AC coil types and high capacity (16 A) types
- Wide insulation distance: 8 mm .315 inch between coil and contact
- High dielectric withstanding for transient protection: JR can withstand 10,000 V surge in  $\mu$ s between coil and contact.
- High inrush current capability: 1 Form A: 111 A inrush (TV-5),
- Slim package for tandem mounting: Header area is 28.6 mm  $\times$  12.8 mm 1.126 $\times$ .504 inch
- Molded materials: all 94 V-0
- "TM" and "TMP" types available
- TÜV also approved

### SPECIFICATIONS

#### Contact

		AC coil type	High capacity type
Arrangement		1 Form A	
Initial contact resistance max. (By voltage drop 6 V DC 1 A)		30 m $\Omega$	
Contact material		Silver alloy	
Rating (resistive)	Nominal switching capacity	10 A 250 V AC 10 A 30 V DC	16 A 250 V AC 16 A 30 V DC
	Maximum switching power	2,500 VA, 300 W	4,000 VA, 480 W
	Maximum switching voltage	250 V AC, 30 V DC	250 V AC, 30 V DC
	Maximum switching current	10 A	16 A
Expected life (min. operations)	Mechanical (180 cpm)	5 $\times$ 10 <sup>6</sup>	
	Electrical (resistive) (20 cpm)	16 A 250 V AC	10 <sup>5</sup>
	10 A 250 V AC	10 <sup>5</sup>	—

#### Coil

	AC coil type	High capacity type
Nominal operating power	1.1 VA/0.9 VA (at 50Hz/60Hz)	530mW

#### Remarks

- \* Specifications will vary with foreign standards certification ratings.
- \*1 Detection current: 10mA
- \*2 Wave is standard shock voltage of  $\pm 1.2 \times 50\mu$ s according to JEC-212-1981
- \*3 With nominal coil voltage and at maximum switching current
- \*4 Half-wave pulse of sine wave: 11ms; detection time: 10 $\mu$ s
- \*5 Half-wave pulse of sine wave: 6ms
- \*6 Detection time: 10 $\mu$ s
- \*7 Refer to 5. Conditions for operation, transport and storage mentioned in AMBIENT ENVIRONMENT (Page 24).

#### Characteristics

		AC coil type	High capacity type
Maximum operating speed		20 cpm	
Initial insulation resistance		Min. 1,000 M $\Omega$ at 500 V DC	
Initial breakdown voltage*1	Between open contacts	1,000 Vrms for 1 min.	
	Between contacts and coil	5,000 Vrms for 1 min.	
Initial surge voltage between coil and contact*2		Min. 10,000 V	
Operate time (at nominal voltage)(at 20°C)		Approx. 10 ms	
Release time (without diode) (at nominal voltage)(at 20°C)		Approx. 6 ms	Approx. 2 ms
Temperature rise*3 (at nominal voltage)		Max. 60°C (10 A, at 20°C)	Max. 45°C (16 A, at 20°C)
Shock resistance	Functional*4	Min. 98 m/s <sup>2</sup> {10 G}	
	Destructive*5	Min. 980 m/s <sup>2</sup> {100 G}	
Vibration resistance	Functional*6	88.2 m/s <sup>2</sup> {9 G}, 10 to 55 Hz at double amplitude of 1.5 mm	
	Destructive	117.6 m/s <sup>2</sup> {12 G}, 10 to 55 Hz at double amplitude of 2.0 mm	
Conditions for operation, transport and storage*7 (Not freezing and condensing at low temperature)	Ambient temp.	-50°C to +55°C -58°F to +131°F	-50°C to +70°C -58°F to +158°F
	Humidity	5 to 85% R.H.	
Unit weight		Approx. 20 g .71 oz	

### TYPICAL APPLICATIONS ORDERING INFORMATION

- Microwave ovens
- Refrigerators
- Copiers
- Facsimiles
- Air conditioners
- Stereo equipment
- TV sets
- Vending machines
- Temperature controllers

Ex. JR 1a — TM — DC12V

Contact arrangement	Mounting method	Coil voltage
1a: 1 Form A	TM: Top mounting	AC 115 V
1aF: High contact capacity (1 Form A)	Nil: PCB terminal TM: Top mounting TMP: Solder and PC terminal	DC 5, 6, 12, 24, 48 V

- Notes: 1. For UL/CSA recognized types, add suffix UL/CSA.  
2. Standard packing: Carton: 100 pcs. Case: 500 pcs.  
3. 18 V DC type are also available. Please consult us for details.

# TYPES

## High contact capacity types

### 1. PC board terminals (Double terminal layout)

Contact arrangement	Coil voltage	Part No.
1a	5 V DC	JR1aF-DC5V
	6 V DC	JR1aF-DC6V
	12 V DC	JR1aF-DC12V
	24 V DC	JR1aF-DC24V
	48 V DC	JR1aF-DC48V

### 2. "TMP" type

Contact arrangement	Coil voltage	Part No.
1a	5 V DC	JR1aF-TMP-DC5V
	6 V DC	JR1aF-TMP-DC6V
	12 V DC	JR1aF-TMP-DC12V
	24 V DC	JR1aF-TMP-DC24V
	48 V DC	JR1aF-TMP-DC48V

### 3. "TM" type

Contact arrangement	Coil voltage	Part No.
1a	5 V DC	JR1aF-TM-DC5V
	6 V DC	JR1aF-TM-DC6V
	12 V DC	JR1aF-TM-DC12V
	24 V DC	JR1aF-TM-DC24V
	48 V DC	JR1aF-TM-DC48V

## AC coil type

1a	115 V AC	JR1a-TM-AC115V
----	----------	----------------

(Notes) 1. For UL/CSA recognized types, add suffix UL/CSA.  
 2. Standard packing Carton: 100 pcs., Case 500 pcs.

## UL CSA TV rating types available

Type	UL	CSA
JR1a AC coil type	TV-5	TV-5
JR1aF high capacity type	TV-5	TV-5

## COIL DATA (at 20°C 68°F)

Contact arrangement	Nominal voltage	Pick-up voltage, (max.) (Initial)	Drop-out voltage, (min.) (Initial)	Coil resistance, Ω (±10%)	Nominal operating current, mA (±10%)	Nominal operating power, mW	Maximum allowable voltage, (at 70°C 158°F)
1 Form A	5 V DC	4.0 V DC	0.5 V DC	47	106	530	5.5 V DC
	6 V DC	4.8 V DC	0.6 V DC	68	88	530	6.6 V DC
	12 V DC	9.6 V DC	1.2 V DC	270	44	530	13.2 V DC
	24 V DC	19.2 V DC	2.4 V DC	1,100	22	530	26.4 V DC
	48 V DC	38.4 V DC	4.8 V DC	4,350	11	530	52.8 V DC
	*115 V AC	92 V AC	34.5 V AC	—	7.8/9.1 (60 Hz)/(50 Hz)	0.9/1.1 VA (60 Hz)/(50 Hz)	126.5V AC (at 20°C 68°F)

Note: Coil resistance varies ±10% for less than 1,000 Ω coil and ±15% for more than 1,000 Ω.  
 For each ±1°C change in ambient temperature, coil resistance varies ±0.4%.  
 \*AC 100 V coil is available only for JR1a-TM type.

## DIMENSIONS

mm inch

### • JR1aF (DC)

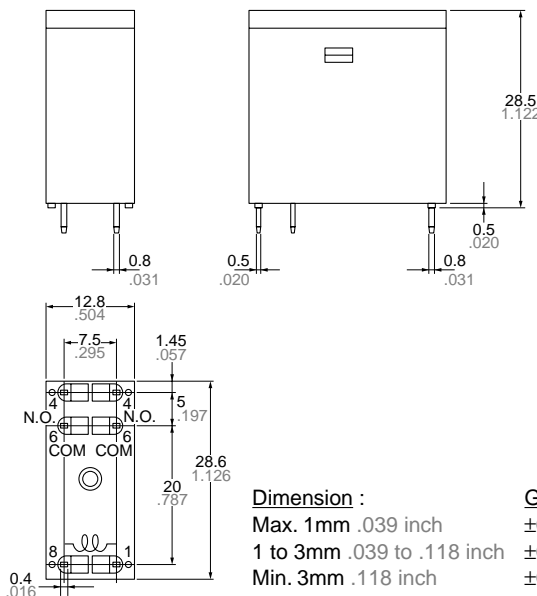

### PC board pattern (Copper-side view)

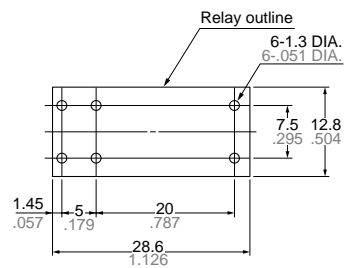

Tolerance: ±0.1 ±.004

### Schematic (BOTTOM VIEW)

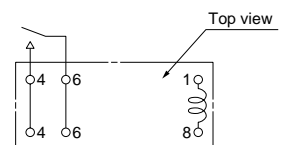

• JR1aF-TMP (DC)

mm inch

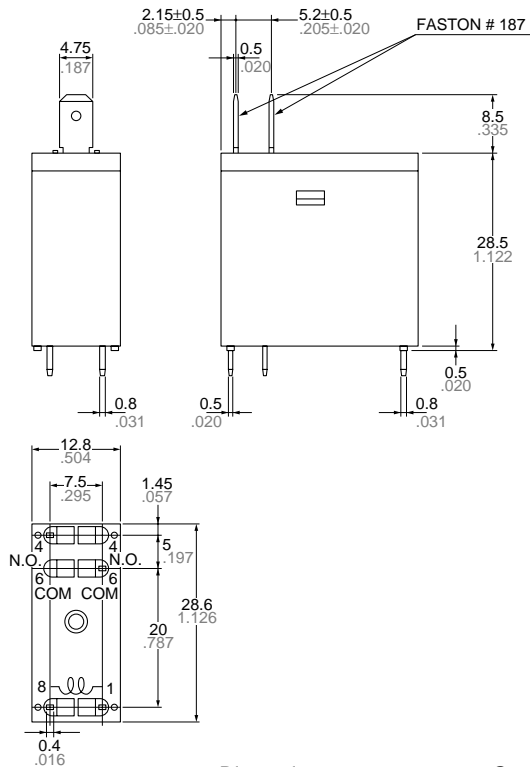

PC board pattern (Copper-side view)

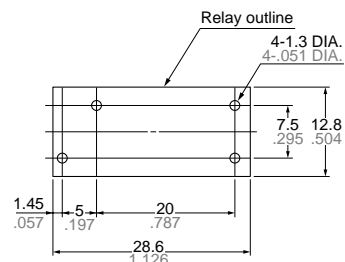

Tolerance: ±0.1 ±.004

Schematic (BOTTOM VIEW)

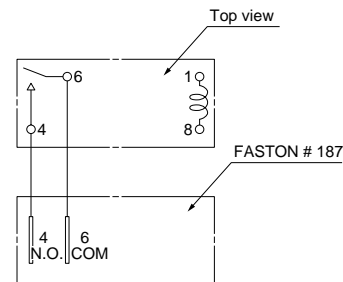

Dimension :	General tolerance
Max. 1mm .039 inch	±0.1 ±.004
1 to 3mm .039 to .118 inch	±0.2 ±.008
Min. 3mm .118 inch	±0.3 ±.012

• JR1aF-TM (DC) / JR1a-TM (AC)

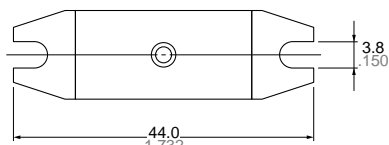

Panel cutout

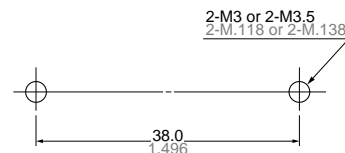

Schematic (BOTTOM VIEW)

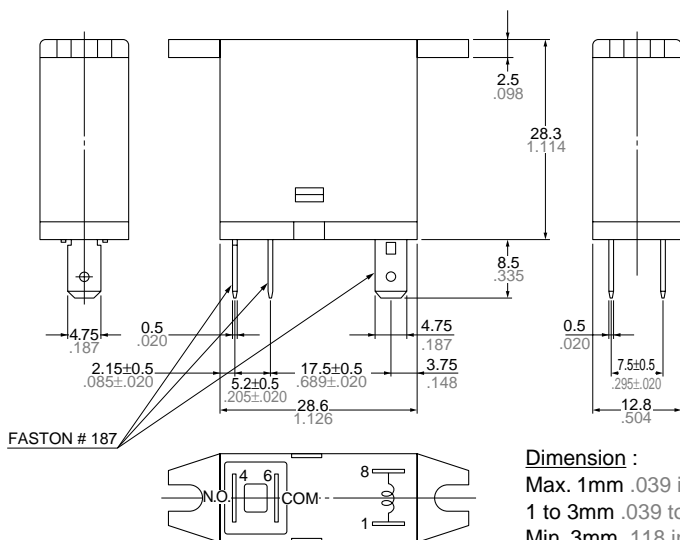
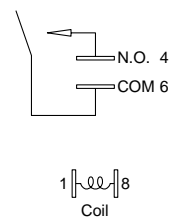

Dimension :	General tolerance
Max. 1mm .039 inch	±0.1 ±.004
1 to 3mm .039 to .118 inch	±0.2 ±.008
Min. 3mm .118 inch	±0.3 ±.012

\* JR1a-TM-AC 100 V is not high contact capacity version but has the same dimensions as JR1aF-TM.

## REFERENCE DATA

### 1. Coil temperature rise

Sample: JR1aF-TM-DC24V

Measurement at coil inside and contact portion

Ambient temperature: 22°C to 25°C 72°F to 77°F

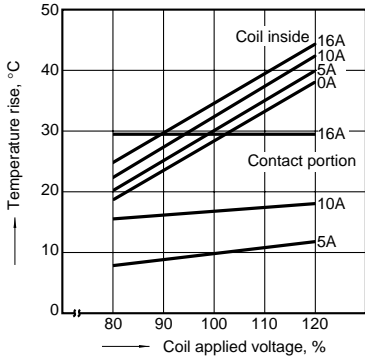

### 2. Operate & release time

Sample: JR1aF-TM-DC24V

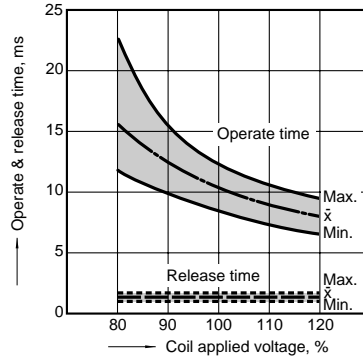

## NOTES

"TM" and "TMP" types of high contact capacity types:

When the contact carrying current exceeds 10 A, the soldering connection at terminals is recommended.

**For Cautions for Use, see Relay Technical Information**