

阅读申明

- 1.本站收集的数据手册和产品资料都来自互联网，版权归原作者所有。如读者和版权方有任何异议请及时告之，我们将妥善解决。
- 2.本站提供的中文数据手册是英文数据手册的中文翻译，其目的是协助用户阅读，该译文无法自动跟随原稿更新，同时也可能存在翻译上的不当。建议读者以英文原稿为参考以便获得更精准的信息。
- 3.本站提供的产品资料，来自厂商的技术支持或者使用者的心得体会等，其内容可能存在描述上的差异，建议读者做出适当判断。
- 4.如需与我们联系，请发邮件到marketing@iczoom.com，主题请标有“数据手册”字样。

Read Statement

1. The datasheets and other product information on the site are all from network reference or other public materials, and the copyright belongs to the original author and original published source. If readers and copyright owners have any objections, please contact us and we will deal with it in a timely manner.
2. The Chinese datasheets provided on the website is a Chinese translation of the English datasheets. Its purpose is for reader's learning exchange only and do not involve commercial purposes. The translation cannot be automatically updated with the original manuscript, and there may also be improper translations. Readers are advised to use the English manuscript as a reference for more accurate information.
3. All product information provided on the website refer to solutions from manufacturers' technical support or users the contents may have differences in description, and readers are advised to take the original article as the standard.
4. If you have any questions, please contact us at marketing@iczoom.com and mark the subject with "Datasheets" .

9091 & 9092 Miniature SIP Relays

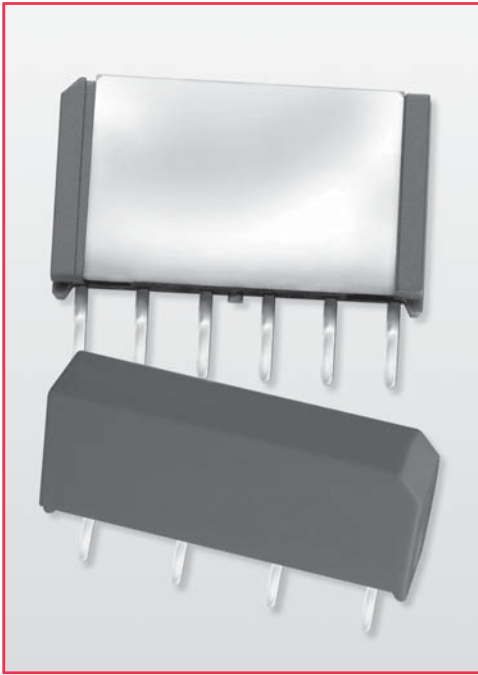

Miniature Molded SIP Reed Relays

The 9091 is a compact version of the 9001 using 40% less board space (LxW). Because of its increased height, the 9092 model allows for incorporation of 2 form A switches in the same board space. These miniature SIP relays utilize Coto's 10W switch technology, making these SIP relays ideal for use in ATE applications and other high reliability test, measurement and telecommunications applications where high board density and long life are key requirements.

Series Features

- ◆ 9091 is a 10W SIP relay measuring .600" x .150" x .275"
- ◆ 9092 is a 10W SIP relay measuring .600" x .150" x .350"
- ◆ Magnetic shield – reduces interaction
- ◆ Optional coil suppression diode protects coil drive circuits
- ◆ UL File # E67117 – (9092 UL Pending)
- ◆ High insulation resistance, $10^{12} \Omega$ minimum
- ◆ High speed switching
- ◆ Molded thermoset body on integral lead frame design
- ◆ High reliability, hermetically sealed contacts for long life

Model 9091

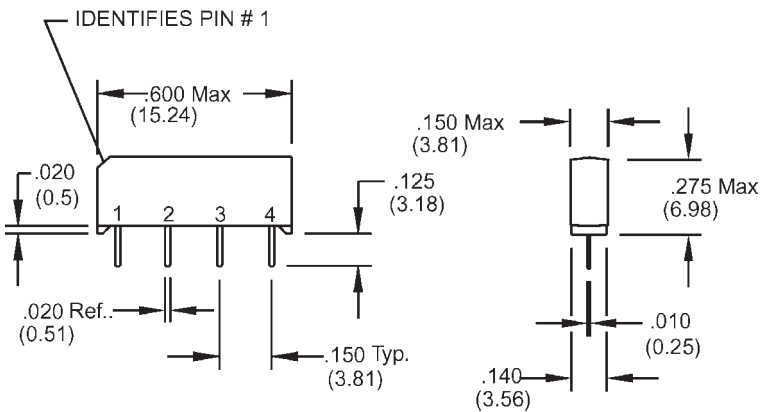

Dimensions in Inches (Millimeters)

Model 9092

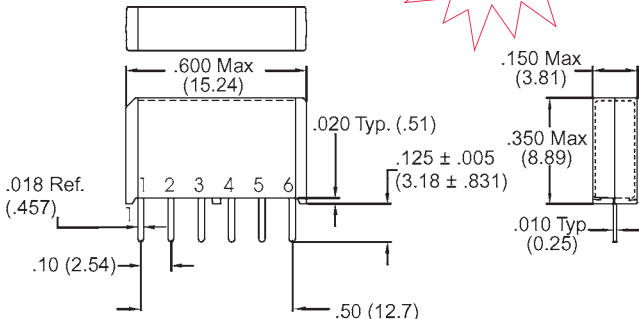

Ordering Information

Part Number	90XX-XX-1X	
Model Number	9091 9092	General Options ²
Coil Voltage	05=5 volts 12=12 volts	0=No Diode 1=Diode
Magnetic Shield	(Optional on Model 9091, Std. on 9092)	
	0=No Shield 1=Mag Shield (9091 Internal, 9092 External)	

9091 & 9092 Miniature SIP Relays



Model Number			9091 ^{2,4} (10 Watt)	9092 ^{2,4} (10 Watt)
Parameters	Test Conditions	Units	1 Form A SIP	2 Form A SIP
COIL SPECS.				
Nom. Coil Voltage		VDC	5 12	5 12
Max. Coil Voltage		VDC	6.5 15.0	6.5 15.0
Coil Resistance	+/- 10%, 25° C	Ω	500 1000	375 750
Operate Voltage	Must Operate by	VDC - Max.	3.75 9.0	3.75 9.0
Release Voltage	Must Release by	VDC - Min.	0.4 1.0	0.4 1.0
CONTACT RATINGS				
Switching Voltage	Max DC/Peak AC Resist.	Volts	200	200
Switching Current	Max DC/Peak AC Resist.	Amps	0.5	0.5
Carry Current	Max DC/Peak AC Resist.	Amps	1.5	1.2
Contact Rating	Max DC/Peak AC Resist.	Watts	10	10
Life Expectancy-Typical ¹	Signal Level 1.0V, 10mA	x 10 ⁶ Ops.	500	500
Static Contact Resistance (max. init.)	50mV, 10mA	Ω	0.125	0.140
Dynamic Contact Resistance (max. init.)	0.5V, 50mA at 100 Hz, 1.5 msec	Ω	0.150	0.200
RELAY SPECIFICATIONS				
Insulation Resistance (minimum)	Between all Isolated Pins at 100V, 25°C, 40% RH	Ω	x 10 ¹²	x 10 ¹²
Capacitance - Typical Across Open Contacts		pF	0.1	1.0
Open Contact to Coil		pF	2.0	1.4
Dielectric Strength (minimum)	Between Contacts	VDC/peak AC	200	200
	Contacts to Coil	VDC/peak AC	1500	1500
Operate Time - including bounce - Typical	At Nominal Coil Voltage, 30 Hz Square Wave	msec.	0.5	0.75
Release Time - Typical	Zener-Diode Suppression ³	msec.	0.30	0.5

Top View:
Grid = .1"x.1" (2.54mm x 2.54mm)

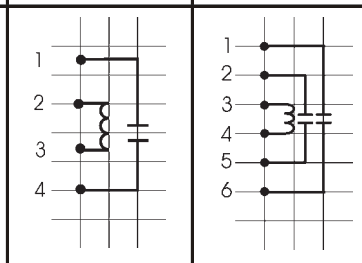

Notes:

¹Consult factory for life expectancy at other switching loads. Resistance >0.5Ω defines end of life or failure to open.

²Optional diode is connected to pin #2 (+) and pin #3(-) for 9091; pin #3 (+) and pin #4(-) for 9092. Correct coil polarity must be observed.

³Consists of 20V Zener-diode and 1N1002 diode in series, connected in parallel with coil.

⁴9091 internal mag shield. 9092 external mag shield.

Environmental Ratings:

Storage Temp: -35°C to +100°C; Operating Temp: -20°C to +85°C
Solder Temp: 270°C max; 10 sec. max

The operate and release voltage and the coil resistance are specified at 25°C. These values vary by approximately 0.4%/°C as the ambient temperature varies.

Vibration: 20 G's to 2000 Hz; Shock: 50 G's