

阅读申明

- 1.本站收集的数据手册和产品资料都来自互联网，版权归原作者所有。如读者和版权方有任何异议请及时告之，我们将妥善解决。
- 2.本站提供的中文数据手册是英文数据手册的中文翻译，其目的是协助用户阅读，该译文无法自动跟随原稿更新，同时也可能存在翻译上的不当。建议读者以英文原稿为参考以便获得更精准的信息。
- 3.本站提供的产品资料，来自厂商的技术支持或者使用者的心得体会等，其内容可能存在描述上的差异，建议读者做出适当判断。
- 4.如需与我们联系，请发邮件到marketing@iczoom.com，主题请标有“数据手册”字样。

Read Statement

1. The datasheets and other product information on the site are all from network reference or other public materials, and the copyright belongs to the original author and original published source. If readers and copyright owners have any objections, please contact us and we will deal with it in a timely manner.
2. The Chinese datasheets provided on the website is a Chinese translation of the English datasheets. Its purpose is for reader's learning exchange only and do not involve commercial purposes. The translation cannot be automatically updated with the original manuscript, and there may also be improper translations. Readers are advised to use the English manuscript as a reference for more accurate information.
3. All product information provided on the website refer to solutions from manufacturers' technical support or users the contents may have differences in description, and readers are advised to take the original article as the standard.
4. If you have any questions, please contact us at marketing@iczoom.com and mark the subject with "Datasheets" .

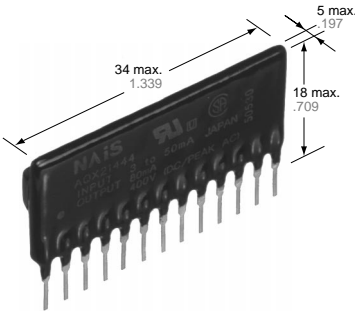

mm inch

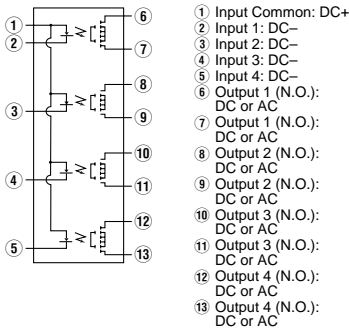

FEATURES

1. 4-circuit (4-Form A) of GU PhotoMOS Relay in a compact and slim 13 pin SIL
2. Applicable for 4 Form A use, as well as 4 independent 1 Form A
3. Controls low-level analog signals
PhotoMOS relays feature extremely low closed-circuit offset voltage to enable control of low-level analog signals without distortion.
4. Low-level off state leakage current (Typical 100 pA at 100 V load voltage)
5. Optical coupling for extremely high isolation
6. Eliminates the need for a counter electromotive protection diode in the drive circuit on the input side

7. PC board layout is simplified
8. Eliminates the need for a separate power supply to drive the power MOS-FET
9. Low thermal electromotive force (Approx. 1 μ V)
10. No restriction on mounting direction
11. No arc, no bounce, no noise

TYPICAL APPLICATIONS

- Telecommunication equipment
- High speed inspection machine, Scanner, IC checker
- Robots

TYPES

	Output rating*		Part No.	Packing quantity	
	Load voltage	Load current		Inner case	Outer carton
AC/DC type	400 V	80 mA	AQX21444	20 pcs.	200 pcs.

*Indicate the peak AC and DC values.

RATINGS

1. AC/DC type

1. Absolute maximum ratings (Ambient temperature: 25°C 77°F)

	Item	Symbol	AQX21444	Remarks
Input	LED forward current	I_F	50 mA	
	LED reverse voltage	V_R	3 V	
	Peak forward current	I_{FP}	1 A	$f = 100$ Hz, Duty factor = 0.1%
	Power dissipation	P_{in}	75 mW	
Output	Load voltage (peak AC)	V_L	400 V	
	Continuous load current	I_L	80 mA (100 mA)	(): in case of using only 1 channel Peak AC, DC
	Peak load current	I_{peak}	0.3 A	100 ms (1 shot), $V_L = DC$
	Power dissipation	P_{out}	1,450 mW	
Total power dissipation		P_T	1,500 mW	
I/O isolation voltage		V_{iso}	1,500 V AC	
Temperature limits	Operating	T_{opr}	-40°C to +85°C -40°F to +185°F	Non-condensing at low temperatures
	Storage	T_{stg}	-40°C to +100°C -40°F to +212°F	

2. Electrical characteristics (Ambient temperature: 25°C 77°F)

Item		Symbol	AQX21444	Condition	
Input	LED operate current	Typical	1.1 mA	I _L = 80 mA	
		Maximum	3 mA		
	LED turn off current	Minimum	0.4 mA	I _L = 80 mA	
		Typical	1.0 mA		
LED dropout voltage	Typical	1.14 V (1.25 V at I _F = 50 mA)		I _F = 5 mA	
	Maximum	1.5 V			
Output	On resistance	Typical	30 Ω	I _F = 5 mA I _L = 80 mA Within 1 s on time	
		Maximum	50 Ω		
	Off state leakage current	Maximum	I _{Leak}		1 μA
Transfer characteristics	Switching speed	Turn on time*	Typical	0.52 ms	I _F = 5 mA
			Maximum	2 ms	I _L = 80 mA
		Turn off time*	Typical	0.29 ms	I _F = 10 mA
			Maximum	1 ms	I _L = 80 mA
	I/O capacitance	Typical	C _{iso}	4.0 pF	f = 1 MHz
		Maximum		8.0 pF	V _B = 0
	Initial I/O isolation resistance	Minimum	R _{iso}	1,000 MΩ	500 V DC
	Vibration resistance	Minimum	—	10 to 55 Hz at double amplitude of 3 mm	2 hours for 3 axes
Shock resistance	Minimum	—	4,900 m/s ² {500 G} 1 ms	3 times for 3 axes	

Note: Recommendable LED forward current I_F = 5 mA.

For type of connection, see page 34.

*Turn on/Turn off time

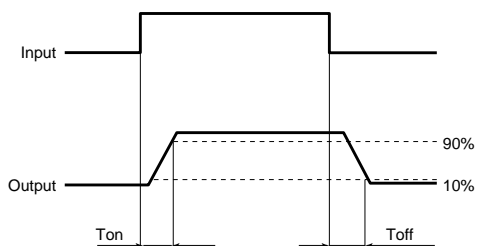

REFERENCE DATA

1. Load current vs. ambient temperature characteristics

Allowable ambient temperature: -40°C to +85°C
-40°F to +185°F

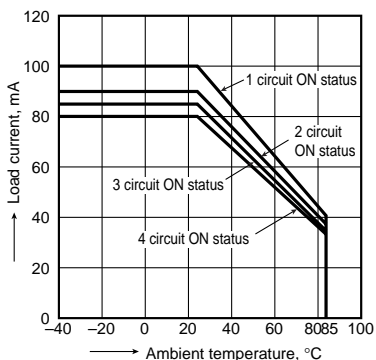

2. Load current in adjacent mounting vs. ambient temperature

Condition: 4 circuits ON status

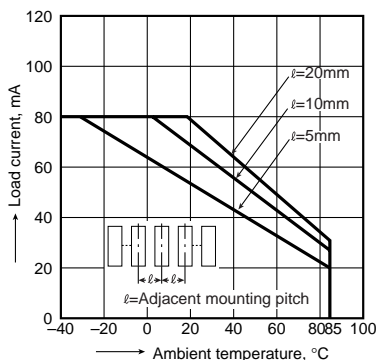

3. On resistance vs. ambient temperature characteristics

Measured portion: between terminals 6 and 7, 8 and 9, 10 and 11, 12 and 13; LED current: 5 mA; Continuous load current: 80 mA (DC)

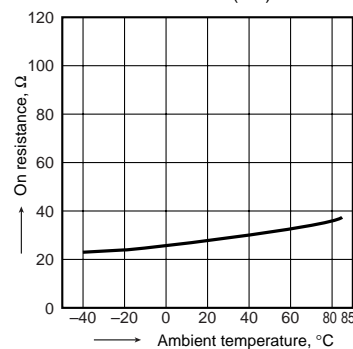

AQX21444

4. Turn on time vs. ambient temperature characteristics

Load voltage: 400 V (DC);
Continuous load current: 80 mA (DC)

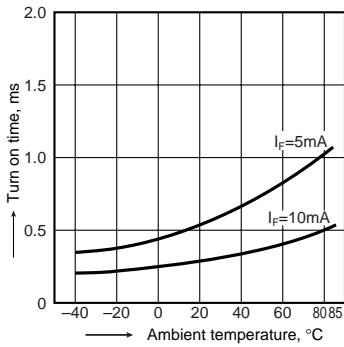

5. Turn off time vs. ambient temperature characteristics

Load voltage: 400 V (DC);
Continuous load current: 80 mA (DC)

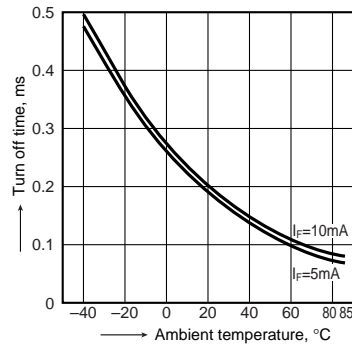

6. LED operate current vs. ambient temperature characteristics

Load voltage: 400 V (DC);
Continuous load current: 80 mA (DC)

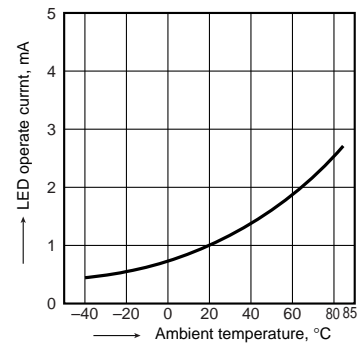

7. LED turn off current vs. ambient temperature characteristics

Load voltage: 400 V (DC);
Continuous load current: 80 mA (DC)

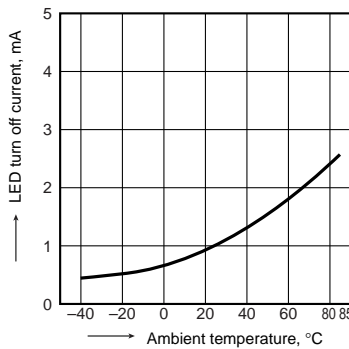

8. LED dropout voltage vs. ambient temperature characteristics

LED current: 5 to 50 mA

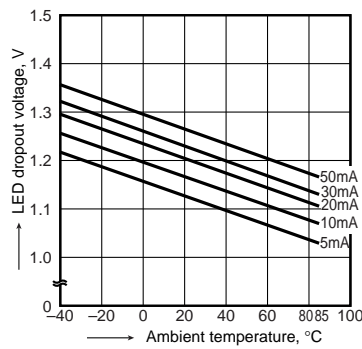

9. Voltage vs. current characteristics of output at MOS portion

Measured portion: between 6 and 7, 8 and 9, 10 and 11, 12 and 13; Ambient temperature: 25°C 77°F

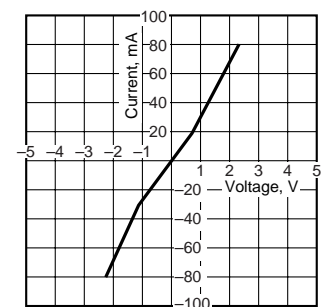

10. Off state leakage current

Measured portion: between terminals 6 and 7, 8 and 9, 10 and 11, 12 and 13;
Ambient temperature: 25°C 77°F

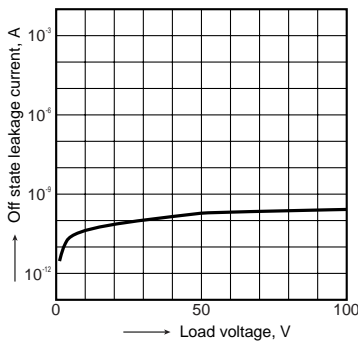

11. LED forward current vs. turn on time characteristics

Measured portion: between terminals 6 and 7, 8 and 9, 10 and 11, 12 and 13; Load voltage: 400 V (DC);
Continuous load current: 80 mA (DC);
Ambient temperature: 25°C 77°F

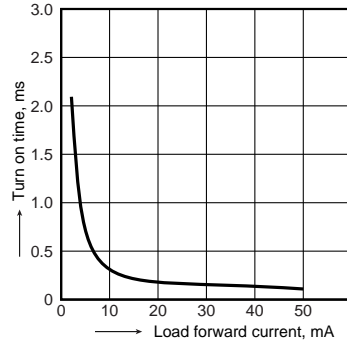

12. LED forward current vs. turn off time characteristics

Measured portion: between terminals 6 and 7, 8 and 9, 10 and 11, 12 and 13; Load voltage: 400 V (DC);
Continuous load current: 80 mA (DC);
Ambient temperature: 25°C 77°F

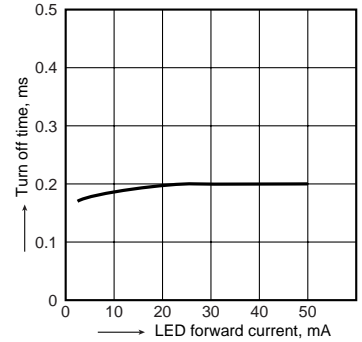

13. Applied voltage vs. output capacitance characteristics (AC/DC type)

Measured portion: between terminals 6 and 7, 8 and 9, 10 and 11, 12 and 13; Load voltage: 400 V (DC);
Frequency: 1 MHz; Ambient temperature: 25°C 77°F

