

阅读申明

- 1.本站收集的数据手册和产品资料都来自互联网，版权归原作者所有。如读者和版权方有任何异议请及时告之，我们将妥善解决。
- 2.本站提供的中文数据手册是英文数据手册的中文翻译，其目的是协助用户阅读，该译文无法自动跟随原稿更新，同时也可能存在翻译上的不当。建议读者以英文原稿为参考以便获得更精准的信息。
- 3.本站提供的产品资料，来自厂商的技术支持或者使用者的心得体会等，其内容可能存在描述上的差异，建议读者做出适当判断。
- 4.如需与我们联系，请发邮件到marketing@iczoom.com，主题请标有“数据手册”字样。

Read Statement

1. The datasheets and other product information on the site are all from network reference or other public materials, and the copyright belongs to the original author and original published source. If readers and copyright owners have any objections, please contact us and we will deal with it in a timely manner.
2. The Chinese datasheets provided on the website is a Chinese translation of the English datasheets. Its purpose is for reader's learning exchange only and do not involve commercial purposes. The translation cannot be automatically updated with the original manuscript, and there may also be improper translations. Readers are advised to use the English manuscript as a reference for more accurate information.
3. All product information provided on the website refer to solutions from manufacturers' technical support or users the contents may have differences in description, and readers are advised to take the original article as the standard.
4. If you have any questions, please contact us at marketing@iczoom.com and mark the subject with "Datasheets" .

Chip Monolithic Ceramic Capacitors

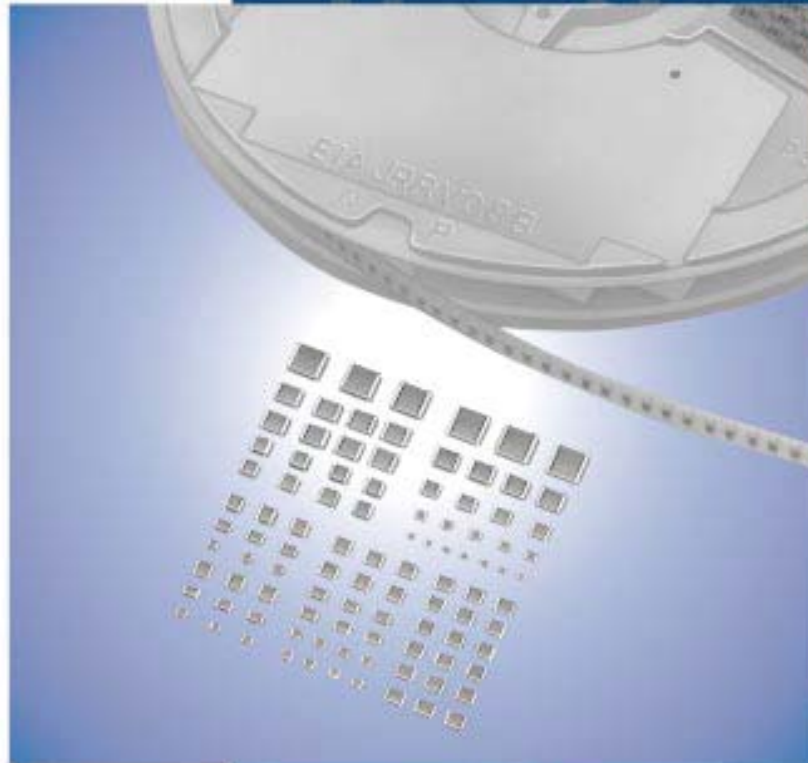

● Part Numbering

Chip Monolithic Ceramic Capacitors

(Part Number)

| | | | | | | | | | |
|----|---|----|---|----|----|-----|---|-----|---|
| GR | M | 18 | 8 | B1 | 1H | 102 | K | A01 | D |
| ① | ② | ③ | ④ | ⑤ | ⑥ | ⑦ | ⑧ | ⑨ | ⑩ |

① Product ID

② Series

| Product ID | Code | Series |
|------------|----------|---|
| GR | J | Soft Termination Type |
| | M | Tin Plated Layer |
| | 4 | Only for Information Devices / Tip & Ring |
| | 7 | Only for Camera Flash Circuit |
| GQ | M | High Frequency for Flow/Reflow Soldering |
| GM | A | Monolithic Microchip |
| | D | For Bonding |
| GN | M | Capacitor Array |
| LL | L | Low ESL Type |
| | R | Controlled ESR Low ESL Type |
| | A | 8-termination Low ESL Type |
| | M | 10-termination Low ESL Type |
| GJ | M | High Frequency Low Loss Type |
| GA | 2 | For AC250V (r.m.s.) |
| | 3 | Safety Standard Certified Type |

③ Dimensions (L×W)

| Code | Dimensions (L×W) | EIA |
|-----------|------------------|--------|
| 02 | 0.4×0.2mm | 01005 |
| 03 | 0.6×0.3mm | 0201 |
| 05 | 0.5×0.5mm | 0202 |
| 08 | 0.8×0.8mm | 0303 |
| 0D | 0.38×0.38mm | 015015 |
| 0M | 0.9×0.6mm | 0302 |
| 15 | 1.0×0.5mm | 0402 |
| 18 | 1.6×0.8mm | 0603 |
| 1M | 1.37×1.0mm | 0504 |
| 21 | 2.0×1.25mm | 0805 |
| 22 | 2.8×2.8mm | 1111 |
| 31 | 3.2×1.6mm | 1206 |
| 32 | 3.2×2.5mm | 1210 |
| 42 | 4.5×2.0mm | 1808 |
| 43 | 4.5×3.2mm | 1812 |
| 52 | 5.7×2.8mm | 2211 |
| 55 | 5.7×5.0mm | 2220 |

④ Dimension (T) (Except GNM)

| Code | Dimension (T) |
|----------|----------------------------------|
| 2 | 0.2mm |
| 3 | 0.3mm |
| 5 | 0.5mm |
| 6 | 0.6mm |
| 7 | 0.7mm |
| 8 | 0.8mm |
| 9 | 0.85mm |
| A | 1.0mm |
| B | 1.25mm |
| C | 1.6mm |
| D | 2.0mm |
| E | 2.5mm |
| F | 3.2mm |
| M | 1.15mm |
| N | 1.35mm |
| Q | 1.5mm |
| R | 1.8mm |
| S | 2.8mm |
| X | Depends on individual standards. |

④ Elements (GNM Only)

| Code | Elements |
|----------|------------|
| 2 | 2-elements |
| 4 | 4-elements |

Continued on the following page.

Please check the MURATA home page (<http://www.murata.com/>) if you cannot find the part number in the catalog.

Continued from the preceding page.

⑤ Temperature Characteristics

| Temperature Characteristic Codes | | | Temperature Characteristics | | | Operating Temperature Range |
|----------------------------------|-----------------|-----|-----------------------------|-------------------|---|-----------------------------|
| Code | Public STD Code | | Reference Temperature | Temperature Range | Capacitance Change or Temperature Coefficient | |
| 1X | SL *1 | JIS | 20°C | 20 to 85°C | +350 to -1000ppm/°C | -55 to 125°C |
| 2C | CH *1 | JIS | 20°C | 20 to 125°C | 0±60ppm/°C | -55 to 125°C |
| 2P | PH *1 | JIS | 20°C | 20 to 85°C | -150±60ppm/°C | -25 to 85°C |
| 2R | RH *1 | JIS | 20°C | 20 to 85°C | -220±60ppm/°C | -25 to 85°C |
| 2S | SH *1 | JIS | 20°C | 20 to 85°C | -330±60ppm/°C | -25 to 85°C |
| 2T | TH *1 | JIS | 20°C | 20 to 85°C | -470±60ppm/°C | -25 to 85°C |
| 3C | CJ *1 | JIS | 20°C | 20 to 125°C | 0±120ppm/°C | -55 to 125°C |
| 3P | PJ *1 | JIS | 20°C | 20 to 85°C | -150±120ppm/°C | -25 to 85°C |
| 3R | RJ *1 | JIS | 20°C | 20 to 85°C | -220±120ppm/°C | -25 to 85°C |
| 3S | SJ *1 | JIS | 20°C | 20 to 85°C | -330±120ppm/°C | -25 to 85°C |
| 3T | TJ *1 | JIS | 20°C | 20 to 85°C | -470±120ppm/°C | -25 to 85°C |
| 3U | UJ *1 | JIS | 20°C | 20 to 85°C | -750±120ppm/°C | -25 to 85°C |
| 4C | CK *1 | JIS | 20°C | 20 to 125°C | 0±250ppm/°C | -55 to 125°C |
| 5C | C0G *1 | EIA | 25°C | 25 to 125°C | 0±30ppm/°C | -55 to 125°C |
| 5G | X8G *1 | EIA | 25°C | 25 to 150°C | 0±30ppm/°C | -55 to 150°C |
| 6C | C0H *1 | EIA | 25°C | 25 to 125°C | 0±60ppm/°C | -55 to 125°C |
| 6P | P2H *1 | EIA | 25°C | 25 to 85°C | -150±60ppm/°C | -55 to 125°C |
| 6R | R2H *1 | EIA | 25°C | 25 to 85°C | -220±60ppm/°C | -55 to 125°C |
| 6S | S2H *1 | EIA | 25°C | 25 to 85°C | -330±60ppm/°C | -55 to 125°C |
| 6T | T2H *1 | EIA | 25°C | 25 to 85°C | -470±60ppm/°C | -55 to 125°C |
| 7U | U2J *1 | EIA | 25°C | 25 to 125°C *6 | -750±120ppm/°C | -55 to 125°C |
| B1 | B *2 | JIS | 20°C | -25 to 85°C | ±10% | -25 to 85°C |
| B3 | B | JIS | 20°C | -25 to 85°C | ±10% | -25 to 85°C |
| C7 | X7S | EIA | 25°C | -55 to 125°C | ±22% | -55 to 125°C |
| C8 | X6S | EIA | 25°C | -55 to 105°C | ±22% | -55 to 105°C |
| D7 | X7T | EIA | 25°C | -55 to 125°C | +22, -33% | -55 to 125°C |
| D8 | X6T | EIA | 25°C | -55 to 105°C | +22, -33% | -55 to 105°C |
| E7 | X7U | EIA | 25°C | -55 to 125°C | +22, -56% | -55 to 125°C |
| F1 | F *2 | JIS | 20°C | -25 to 85°C | +30, -80% | -25 to 85°C |
| F5 | Y5V | EIA | 25°C | -30 to 85°C | +22, -82% | -30 to 85°C |
| L8 | X8L | *3 | 25°C | -55 to 150°C | +15, -40% | -55 to 150°C |
| R1 | R *2 | JIS | 20°C | -55 to 125°C | ±15% | -55 to 125°C |
| R3 | R | JIS | 20°C | -55 to 125°C | ±15% | -55 to 125°C |
| R6 | X5R | EIA | 25°C | -55 to 85°C | ±15% | -55 to 85°C |
| R7 | X7R | EIA | 25°C | -55 to 125°C | ±15% | -55 to 125°C |
| R9 | X8R | EIA | 25°C | -55 to 150°C | ±15% | -55 to 150°C |
| W0 | - | - | 25°C | -55 to 125°C | ±10% *4 | -55 to 125°C |
| | | | | | +22, -33% *5 | |

*1 Please refer to table for Capacitance Change under reference temperature.

*2 Capacitance change is specified with 50% rated voltage applied.

*3 Murata Temperature Characteristic Code.

*4 Apply DC350V bias.

*5 No DC bias.

*6 Rated Voltage 100Vdc max : 25 to 85°C

Continued on the following page. 

Continued from the preceding page.

●Capacitance Change from each temperature

JIS Code

| Murata Code | Capacitance Change from 20°C (%) | | | | | |
|-------------|----------------------------------|-------|-------|-------|-------|-------|
| | -55°C | | -25°C | | -10°C | |
| | Max. | Min. | Max. | Min. | Max. | Min. |
| 1X | - | - | - | - | - | - |
| 2C | 0.82 | -0.45 | 0.49 | -0.27 | 0.33 | -0.18 |
| 2P | - | - | 1.32 | 0.41 | 0.88 | 0.27 |
| 2R | - | - | 1.70 | 0.72 | 1.13 | 0.48 |
| 2S | - | - | 2.30 | 1.22 | 1.54 | 0.81 |
| 2T | - | - | 3.07 | 1.85 | 2.05 | 1.23 |
| 3C | 1.37 | -0.90 | 0.82 | -0.54 | 0.55 | -0.36 |
| 3P | - | - | 1.65 | 0.14 | 1.10 | 0.09 |
| 3R | - | - | 2.03 | 0.45 | 1.35 | 0.30 |
| 3S | - | - | 2.63 | 0.95 | 1.76 | 0.63 |
| 3T | - | - | 3.40 | 1.58 | 2.27 | 1.05 |
| 3U | - | - | 4.94 | 2.84 | 3.29 | 1.89 |
| 4C | 2.56 | -1.88 | 1.54 | -1.13 | 1.02 | -0.75 |

EIA Code

| Murata Code | Capacitance Change from 25°C (%) | | | | | |
|-------------|----------------------------------|-------|-------|-------|-------|-------|
| | -55°C | | -30°C | | -10°C | |
| | Max. | Min. | Max. | Min. | Max. | Min. |
| 5C/5G | 0.58 | -0.24 | 0.40 | -0.17 | 0.25 | -0.11 |
| 6C | 0.87 | -0.48 | 0.59 | -0.33 | 0.38 | -0.21 |
| 6P | 2.33 | 0.72 | 1.61 | 0.50 | 1.02 | 0.32 |
| 6R | 3.02 | 1.28 | 2.08 | 0.88 | 1.32 | 0.56 |
| 6S | 4.09 | 2.16 | 2.81 | 1.49 | 1.79 | 0.95 |
| 6T | 5.46 | 3.28 | 3.75 | 2.26 | 2.39 | 1.44 |
| 7U | 8.78 | 5.04 | 6.04 | 3.47 | 3.84 | 2.21 |

⑥Rated Voltage

| Code | Rated Voltage |
|------|---|
| 0E | DC2.5V |
| 0G | DC4V |
| 0J | DC6.3V |
| 1A | DC10V |
| 1C | DC16V |
| 1E | DC25V |
| YA | DC35V |
| 1H | DC50V |
| 2A | DC100V |
| 2D | DC200V |
| 2E | DC250V |
| YD | DC300V |
| 2H | DC500V |
| 2J | DC630V |
| 3A | DC1kV |
| 3D | DC2kV |
| 3F | DC3.15kV |
| BB | DC350V (for Camera Flash Circuit) |
| E2 | AC250V |
| GC | X1/Y2; AC250V (Safety Standard Certified Type GC) |
| GF | Y2, X1/Y2; AC250V (Safety Standard Certified Type GF) |
| GD | Y3; AC250V (Safety Standard Certified Type GD) |
| GB | X2; AC250V (Safety Standard Certified Type GB) |

⑦Capacitance

Expressed by three-digit alphanumerics. The unit is picofarad (pF). The first and second figures are significant digits, and the third figure expresses the number of zeros which follow the two numbers. If there is a decimal point, it is expressed by the capital letter "R." In this case, all figures are significant digits.

Ex.)

| Code | Capacitance |
|------|-------------|
| R50 | 0.5pF |
| 1R0 | 1.0pF |
| 100 | 10pF |
| 103 | 10000pF |

Continued on the following page. 

Please check the MURATA home page (<http://www.murata.com/>) if you cannot find the part number in the catalog.

Continued from the preceding page.

⑧ Capacitance Tolerance

| Code | Capacitance Tolerance | TC | Series | Capacitance Step | |
|----------|----------------------------------|---------------------|------------------------|------------------|-------------------------|
| W | ±0.05pF | CΔ | GRM/GJM | ≤9.9pF | 0.1pF |
| B | ±0.1pF | CΔ | GRM/GJM | ≤9.9pF | 0.1pF |
| | | | GQM | ≤1pF | 0.1pF |
| C | ±0.25pF | CΔ | GRM/GJM | ≤9.9pF | 1pF Step and E24 Series |
| | | except CΔ | GRM | ≤5pF | * 1pF |
| | | CΔ | GQM | ≤1pF | 0.1pF |
| D | ±0.5pF | CΔ | GRM/GJM | 1.1 to 9.9pF | 1pF Step and E24 Series |
| | | except CΔ | GRM | 5.1 to 9.9pF | 0.1pF |
| | | CΔ | GQM | 5.1 to 9.9pF | * 1pF |
| G | ±2% | CΔ | GJM | ≥10pF | E12 Series |
| | | CΔ | GQM | ≥10pF | E24 Series |
| J | ±5% | CΔ, SL, U2J | GRM/GA3 | ≥10pF | E12 Series |
| | | CΔ | GQM/GJM | ≥10pF | E24 Series |
| K | ±10% | B, R, X7R, X5R, ZLM | GRJ/GRM/GR7/GA3 | E6 Series | |
| | | C0G | GNM | E6 Series | |
| | | B, R, X7R, X5R, ZLM | GR4, GMD | E12 Series | |
| M | ±20% | B, R, X7R, X7S | GRM/GMA | E6 Series | |
| | | X5R, X7R, X7S | GNM | E3 Series | |
| | | X7R | GA2 | E3 Series | |
| | | X5R, X7R, X7S, X6S | LLL/LLR/LLA/LLM | E3 Series | |
| Z | +80%, -20% | F, Y5V | GRM | E3 Series | |
| R | Depends on individual standards. | | | | |

* E24 series is also available.

⑨ Individual Specification Code (Except LLR)

Expressed by three figures.

⑨ ESR (LLR Only)

| Code | ESR |
|------------|--------|
| E01 | 100mΩ |
| E03 | 220mΩ |
| E05 | 470mΩ |
| E07 | 1000mΩ |

⑩ Packaging

| Code | Packaging |
|----------|-----------------------------|
| L | ø180mm Embossed Taping |
| D | ø180mm Paper Taping |
| E | ø180mm Paper Taping (LLL15) |
| K | ø330mm Embossed Taping |
| J | ø330mm Paper Taping |
| F | ø330mm Paper Taping (LLL15) |
| B | Bulk |
| C | Bulk Case |
| T | Bulk Tray |

Please check the MURATA home page (<http://www.murata.com/>) if you cannot find the part number in the catalog.

Chip Monolithic Ceramic Capacitors



AC250V Type (Which Meet Japanese Law) GA2 Series

■ Features

1. Chip monolithic ceramic capacitor for AC lines.
2. A new monolithic structure for small, high capacitance capable of operating at high voltage levels.
3. Sn-plated external electrodes realize good solderability.
4. Only for reflow soldering
5. Capacitance 0.01 to 0.1uF for connecting lines and 470 to 4700pF for connecting lines to earth.

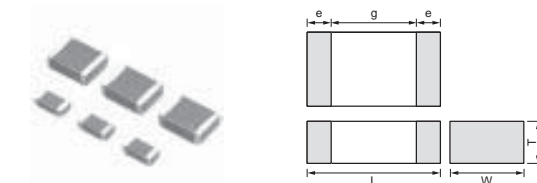

| Part Number | Dimensions (mm) | | | | |
|-------------|-----------------|----------|--------------|--------|--------|
| | L | W | T | e min. | g min. |
| GA242Q | 4.5 ±0.3 | 2.0 ±0.2 | 1.5 +0, -0.3 | 0.3 | 2.5 |
| GA243D | 4.5 ±0.4 | 3.2 ±0.3 | 2.0 +0, -0.3 | | |
| GA243Q | | | 1.5 +0, -0.3 | | |
| GA255D | 5.7 ±0.4 | 5.0 ±0.4 | 2.0 +0, -0.3 | | 3.2 |

■ Applications

Noise suppression filters for switching power supplies, telephones, facsimiles, modems.

Do not use these products in any Automotive Power train or Safety equipment including Battery chargers for Electric Vehicles and Plug-in Hybrids. Only Murata products clearly stipulated as "for Automotive use" can be used for automobile applications such as Power train and Safety equipment.

■ Reference Standard

GA2 series obtains no safety approval. This series is based on the standards of the electrical appliance and material safety law of Japan (separated table 4).

| Part Number | Rated Voltage (V) | TC Code (Standard) | Capacitance | Length L (mm) | Width W (mm) | Thickness T (mm) | Electrode g min. (mm) | Electrode e (mm) |
|--------------------|-------------------|--------------------|--------------|---------------|--------------|------------------|-----------------------|------------------|
| GA242QR7E2471MW01L | AC250 (r.m.s.) | X7R (EIA) | 470pF ±20% | 4.5 | 2.0 | 1.5 | 2.5 | 0.3 min. |
| GA242QR7E2102MW01L | AC250 (r.m.s.) | X7R (EIA) | 1000pF ±20% | 4.5 | 2.0 | 1.5 | 2.5 | 0.3 min. |
| GA243QR7E2222MW01L | AC250 (r.m.s.) | X7R (EIA) | 2200pF ±20% | 4.5 | 3.2 | 1.5 | 2.5 | 0.3 min. |
| GA243QR7E2332MW01L | AC250 (r.m.s.) | X7R (EIA) | 3300pF ±20% | 4.5 | 3.2 | 1.5 | 2.5 | 0.3 min. |
| GA243DR7E2472MW01L | AC250 (r.m.s.) | X7R (EIA) | 4700pF ±20% | 4.5 | 3.2 | 2.0 | 2.5 | 0.3 min. |
| GA243QR7E2103MW01L | AC250 (r.m.s.) | X7R (EIA) | 10000pF ±20% | 4.5 | 3.2 | 1.5 | 2.5 | 0.3 min. |
| GA243QR7E2223MW01L | AC250 (r.m.s.) | X7R (EIA) | 22000pF ±20% | 4.5 | 3.2 | 1.5 | 2.5 | 0.3 min. |
| GA243DR7E2473MW01L | AC250 (r.m.s.) | X7R (EIA) | 47000pF ±20% | 4.5 | 3.2 | 2.0 | 2.5 | 0.3 min. |
| GA255DR7E2104MW01L | AC250 (r.m.s.) | X7R (EIA) | 0.10μF ±20% | 5.7 | 5.0 | 2.0 | 3.2 | 0.3 min. |

For General Purpose GRM/GRJ Series

Only for Applications

AC250V Type GA2 Series

Safety Standard Certified GA3 Series

Product Information

GA2 Series Specifications and Test Methods

For General Purpose GRM/GRJ Series

Only for Applications

AC250V Type GA2 Series

Safety Standard Certified GA3 Series

Product Information

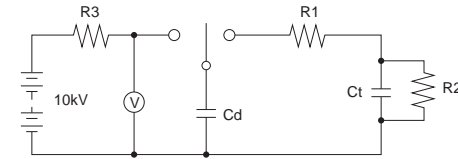
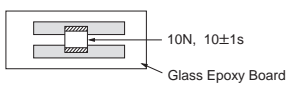
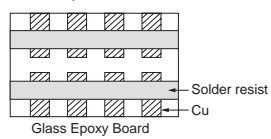
| No. | Item | Specifications | Test Method | | | | | | | | | | | | |
|---------------------|--|---|---|---------------------|------------------|--------------|-----------------|--------------|------------------------|---|------|---|------------------------|---|------|
| 1 | Operating Temperature Range | -55 to +125°C | — | | | | | | | | | | | | |
| 2 | Appearance | No defects or abnormalities | Visual inspection | | | | | | | | | | | | |
| 3 | Dimensions | Within the specified dimensions | Using calipers and micrometers | | | | | | | | | | | | |
| 4 | Dielectric Strength | No defects or abnormalities | No failure should be observed when voltage in the table is applied between the terminations for 60±1 sec., provided the charge/discharge current is less than 50mA. <table border="1" style="margin-left: auto; margin-right: auto;"> <thead> <tr> <th>Nominal Capacitance</th> <th>Test Voltage</th> </tr> </thead> <tbody> <tr> <td>C ≥ 10,000pF</td> <td>AC575V (r.m.s.)</td> </tr> <tr> <td>C < 10,000pF</td> <td>AC1500V (r.m.s.)</td> </tr> </tbody> </table> | Nominal Capacitance | Test Voltage | C ≥ 10,000pF | AC575V (r.m.s.) | C < 10,000pF | AC1500V (r.m.s.) | | | | | | |
| Nominal Capacitance | Test Voltage | | | | | | | | | | | | | | |
| C ≥ 10,000pF | AC575V (r.m.s.) | | | | | | | | | | | | | | |
| C < 10,000pF | AC1500V (r.m.s.) | | | | | | | | | | | | | | |
| 5 | Insulation Resistance (I.R.) | More than 2,000MΩ | The insulation resistance should be measured with DC500±50V and within 60±5 sec. of charging. | | | | | | | | | | | | |
| 6 | Capacitance | Within the specified tolerance | The capacitance/D.F. should be measured at a frequency of 1±0.2kHz and a voltage of AC1±0.2V (r.m.s.) | | | | | | | | | | | | |
| 7 | Dissipation Factor (D.F.) | 0.025 max. | | | | | | | | | | | | | |
| 8 | Capacitance Temperature Characteristics | Cap. Change Within ±15% (Temp. Range: -55 to +125°C) | The capacitance measurement should be made at each step specified in the Table. <table border="1" style="margin-left: auto; margin-right: auto;"> <thead> <tr> <th>Step</th> <th>Temperature (°C)</th> </tr> </thead> <tbody> <tr> <td>1</td> <td>25±2</td> </tr> <tr> <td>2</td> <td>Min. Operating Temp.±3</td> </tr> <tr> <td>3</td> <td>25±2</td> </tr> <tr> <td>4</td> <td>Max. Operating Temp.±2</td> </tr> <tr> <td>5</td> <td>25±2</td> </tr> </tbody> </table> <p>•Pretreatment Perform a heat treatment at 150±,8°C for 60±5 min. and then let sit for 24±2 hrs. at room condition.*</p> | Step | Temperature (°C) | 1 | 25±2 | 2 | Min. Operating Temp.±3 | 3 | 25±2 | 4 | Max. Operating Temp.±2 | 5 | 25±2 |
| Step | Temperature (°C) | | | | | | | | | | | | | | |
| 1 | 25±2 | | | | | | | | | | | | | | |
| 2 | Min. Operating Temp.±3 | | | | | | | | | | | | | | |
| 3 | 25±2 | | | | | | | | | | | | | | |
| 4 | Max. Operating Temp.±2 | | | | | | | | | | | | | | |
| 5 | 25±2 | | | | | | | | | | | | | | |
| 9 | Discharge Test (Application: Nominal Capacitance C < 10,000pF) | Appearance | No defects or abnormalities <p>As in Fig., discharge is made 50 times at 5 sec. intervals from the capacitor (Cd) charged at DC voltage of specified.</p>  <p>Ct: Capacitor under test Cd: 0.001μF R1: 1,000Ω R2: 100MΩ R3: Surge resistance</p> | | | | | | | | | | | | |
| 10 | Adhesive Strength of Termination | No removal of the terminations or other defects should occur. | Solder the capacitor to the testing jig (glass epoxy board) shown in Fig. 1. Then apply 10N force in the direction of the arrow. The soldering should be done using the reflow method and should be conducted with care so that the soldering is uniform and free of defects such as heat shock.  <p>Fig. 1</p> | | | | | | | | | | | | |
| 11 | Vibration Resistance | Appearance | No defects or abnormalities | | | | | | | | | | | | |
| | | Capacitance | Within the specified tolerance | | | | | | | | | | | | |
| | D.F. | 0.025 max. | The capacitor should be subjected to a simple harmonic motion having a total amplitude of 1.5mm, the frequency being varied uniformly between the approximate limits of 10 and 55Hz. The frequency range, from 10 to 55Hz and return to 10Hz, should be traversed in approximately 1 min. This motion should be applied for a period of 2 hrs. in each of 3 mutually perpendicular directions (total of 6 hrs.).  | | | | | | | | | | | | |

* "Room condition" Temperature: 15 to 35°C, Relative humidity: 45 to 75%, Atmospheric pressure: 86 to 106kPa

Continued on the following page.

GA2 Series Specifications and Test Methods

Continued from the preceding page.

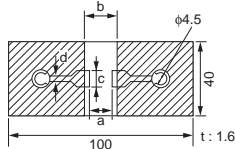
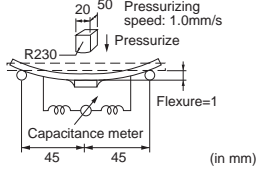
| No. | Item | Specifications | Test Method | | | | | | | | | | | | | | | | | | | |
|---------------------|------------------------------|---|--|---|----------------|------------------|-------------|---|------------------------|--------|---|--------------|---------|-----|------------------------|------|-----|------------|--------|-----|-----|---------|
| 12 | Deflection | No marking defects | Solder the capacitor to the testing jig (glass epoxy board) shown in Fig. 2. Then apply a force in the direction shown in Fig. 3. The soldering should be done using the reflow method and should be conducted with care so that the soldering is uniform and free of defects such as heat shock. | | | | | | | | | | | | | | | | | | | |
| | | <div style="text-align: center;">  <p>Fig. 2</p> <table border="1" style="margin-left: auto; margin-right: auto;"> <thead> <tr> <th rowspan="2">L×W (mm)</th> <th colspan="4">Dimension (mm)</th> </tr> <tr> <th>a</th> <th>b</th> <th>c</th> <th>d</th> </tr> </thead> <tbody> <tr> <td>4.5×2.0</td> <td>3.5</td> <td>7.0</td> <td>2.4</td> <td rowspan="3" style="text-align: center;">1.0</td> </tr> <tr> <td>4.5×3.2</td> <td>3.5</td> <td>7.0</td> <td>3.7</td> </tr> <tr> <td>5.7×5.0</td> <td>4.5</td> <td>8.0</td> <td>5.6</td> </tr> </tbody> </table> </div> | | L×W (mm) | Dimension (mm) | | | | a | b | c | d | 4.5×2.0 | 3.5 | 7.0 | 2.4 | 1.0 | 4.5×3.2 | 3.5 | 7.0 | 3.7 | 5.7×5.0 |
| L×W (mm) | Dimension (mm) | | | | | | | | | | | | | | | | | | | | | |
| | a | b | c | d | | | | | | | | | | | | | | | | | | |
| 4.5×2.0 | 3.5 | 7.0 | 2.4 | 1.0 | | | | | | | | | | | | | | | | | | |
| 4.5×3.2 | 3.5 | 7.0 | 3.7 | | | | | | | | | | | | | | | | | | | |
| 5.7×5.0 | 4.5 | 8.0 | 5.6 | | | | | | | | | | | | | | | | | | | |
| 13 | Solderability of Termination | 75% of the terminations are to be soldered evenly and continuously. | Immerse the capacitor in a solution of ethanol (JIS-K-8101) and rosin (JIS-K-5902) (25% rosin in weight proportion). Immerse in solder solution for 2±0.5 sec. Immersing speed: 25±2.5mm/s Temp. of solder: 245±5°C Lead Free Solder (Sn-3.0Ag-0.5Cu) 235±5°C H60A or H63A Eutectic Solder | | | | | | | | | | | | | | | | | | | |
| | | <div style="text-align: center;">  <p>Fig. 3</p> </div> | | | | | | | | | | | | | | | | | | | | |
| 14 | Humidity Insulation | Appearance | No marking defects | The capacitor should be subjected to 40±2°C, relative humidity of 90 to 98% for 8 hrs., and then removed in room condition* for 16 hrs. until 5 cycles. | | | | | | | | | | | | | | | | | | |
| | | Capacitance Change | Within ±15% | | | | | | | | | | | | | | | | | | | |
| | | D.F. | 0.05 max. | | | | | | | | | | | | | | | | | | | |
| | | I.R. | More than 1,000MΩ | | | | | | | | | | | | | | | | | | | |
| | | Dielectric Strength | In accordance with item No.4 | | | | | | | | | | | | | | | | | | | |
| 15 | Resistance to Soldering Heat | Appearance | No marking defects | Preheat the capacitor as in table. Immerse the capacitor in solder solution at 260±5°C for 10±1 sec. Let sit at room condition* for 24±2 hrs., then measure. •Immersing speed: 25±2.5mm/s •Pretreatment Perform a heat treatment at 150±1.0°C for 60±5 min. and then let sit for 24±2 hrs. at room condition.* *Preheating <table border="1" style="margin-left: auto; margin-right: auto; width: 100%;"> <thead> <tr> <th>Step</th> <th>Temperature</th> <th>Time</th> </tr> </thead> <tbody> <tr> <td>1</td> <td>100 to 120°C</td> <td>1 min.</td> </tr> <tr> <td>2</td> <td>170 to 200°C</td> <td>1 min.</td> </tr> </tbody> </table> | Step | Temperature | Time | 1 | 100 to 120°C | 1 min. | 2 | 170 to 200°C | 1 min. | | | | | | | | | |
| | | Step | Temperature | | Time | | | | | | | | | | | | | | | | | |
| | | 1 | 100 to 120°C | | 1 min. | | | | | | | | | | | | | | | | | |
| | | 2 | 170 to 200°C | | 1 min. | | | | | | | | | | | | | | | | | |
| | | Capacitance Change | Within ±10% | | | | | | | | | | | | | | | | | | | |
| D.F. | 0.025 max. | | | | | | | | | | | | | | | | | | | | | |
| I.R. | More than 2,000MΩ | | | | | | | | | | | | | | | | | | | | | |
| Dielectric Strength | In accordance with item No.4 | | | | | | | | | | | | | | | | | | | | | |
| 16 | Temperature Cycle | Appearance | No marking defects | Fix the capacitor to the supporting jig (glass epoxy board) shown in Fig. 4. Perform the 5 cycles according to the 4 heat treatments listed in the following table. Let sit for 24±2 hrs. at room condition,* then measure. <table border="1" style="margin-left: auto; margin-right: auto; width: 100%;"> <thead> <tr> <th>Step</th> <th>Temperature (°C)</th> <th>Time (min.)</th> </tr> </thead> <tbody> <tr> <td>1</td> <td>Min. Operating Temp.±3</td> <td>30±3</td> </tr> <tr> <td>2</td> <td>Room Temp.</td> <td>2 to 3</td> </tr> <tr> <td>3</td> <td>Max. Operating Temp.±2</td> <td>30±3</td> </tr> <tr> <td>4</td> <td>Room Temp.</td> <td>2 to 3</td> </tr> </tbody> </table> | Step | Temperature (°C) | Time (min.) | 1 | Min. Operating Temp.±3 | 30±3 | 2 | Room Temp. | 2 to 3 | 3 | Max. Operating Temp.±2 | 30±3 | 4 | Room Temp. | 2 to 3 | | | |
| | | Step | Temperature (°C) | | Time (min.) | | | | | | | | | | | | | | | | | |
| | | 1 | Min. Operating Temp.±3 | | 30±3 | | | | | | | | | | | | | | | | | |
| | | 2 | Room Temp. | | 2 to 3 | | | | | | | | | | | | | | | | | |
| | | 3 | Max. Operating Temp.±2 | | 30±3 | | | | | | | | | | | | | | | | | |
| 4 | Room Temp. | 2 to 3 | | | | | | | | | | | | | | | | | | | | |
| Capacitance Change | Within ±15% | | | | | | | | | | | | | | | | | | | | | |
| D.F. | 0.05 max. | | | | | | | | | | | | | | | | | | | | | |
| I.R. | More than 2,000MΩ | | | | | | | | | | | | | | | | | | | | | |
| Dielectric Strength | In accordance with item No.4 | | | | | | | | | | | | | | | | | | | | | |

* "Room condition" Temperature: 15 to 35°C, Relative humidity: 45 to 75%, Atmospheric pressure: 86 to 106kPa

Continued on the following page.

For General Purpose GRM/GRJ Series

Only for Applications

AC250V Type GA2 Series

Safety Standard Certified GA3 Series

Product Information

GA2 Series Specifications and Test Methods

Continued from the preceding page.

| No. | Item | Specifications | Test Method | | | | | | | | | |
|--------------------------|----------------------------|---------------------|---|---------------------|-----------|--------------|--------------------------|----------------------------|-----------------|-----------------------|----------------------------|------------------|
| 17 | Humidity (Steady State) | Appearance | No marking defects | | | | | | | | | |
| | | Capacitance Change | Within $\pm 15\%$ | | | | | | | | | |
| | | D.F. | 0.05 max. | | | | | | | | | |
| | | I.R. | More than 1,000M Ω | | | | | | | | | |
| | | Dielectric Strength | In accordance with item No.4 | | | | | | | | | |
| | | | Let the capacitor sit at 40 $\pm 2^{\circ}\text{C}$ and relative humidity of 90 to 95% for 500 $\pm 2^{\circ}$ hrs. Remove and let sit for 24 ± 2 hrs. at room condition,* then measure. •Pretreatment Perform a heat treatment at 150 $\pm 1^{\circ}\text{C}$ for 60 ± 5 min. and then let sit for 24 ± 2 hrs. at room condition.* | | | | | | | | | |
| 18 | Life | Appearance | No marking defects | | | | | | | | | |
| | | Capacitance Change | Within $\pm 20\%$ | | | | | | | | | |
| | | D.F. | 0.05 max. | | | | | | | | | |
| | | I.R. | More than 1,000M Ω | | | | | | | | | |
| | | Dielectric Strength | In accordance with item No.4 | | | | | | | | | |
| | | | Apply voltage and time as in Table at maximum operating temperature $\pm 3^{\circ}\text{C}$. Remove and let sit for 24 ± 2 hrs. at room condition,* then measure. The charge / discharge current is less than 50mA. <table border="1" style="margin-left: auto; margin-right: auto;"> <thead> <tr> <th>Nominal Capacitance</th> <th>Test Time</th> <th>Test Voltage</th> </tr> </thead> <tbody> <tr> <td>$C \geq 10,000\text{pF}$</td> <td>1,000$\pm 4^{\circ}$ hrs.</td> <td>AC300V (r.m.s.)</td> </tr> <tr> <td>$C < 10,000\text{pF}$</td> <td>1,500$\pm 4^{\circ}$ hrs.</td> <td>AC500V (r.m.s.)*</td> </tr> </tbody> </table> * Except that once each hour the voltage is increased to AC1,000V (r.m.s.) for 0.1 sec. •Pretreatment Apply test voltage for 60 ± 5 min. at test temperature. Remove and let sit for 24 ± 2 hrs. at room condition.* | Nominal Capacitance | Test Time | Test Voltage | $C \geq 10,000\text{pF}$ | 1,000 $\pm 4^{\circ}$ hrs. | AC300V (r.m.s.) | $C < 10,000\text{pF}$ | 1,500 $\pm 4^{\circ}$ hrs. | AC500V (r.m.s.)* |
| Nominal Capacitance | Test Time | Test Voltage | | | | | | | | | | |
| $C \geq 10,000\text{pF}$ | 1,000 $\pm 4^{\circ}$ hrs. | AC300V (r.m.s.) | | | | | | | | | | |
| $C < 10,000\text{pF}$ | 1,500 $\pm 4^{\circ}$ hrs. | AC500V (r.m.s.)* | | | | | | | | | | |
| 19 | Humidity Loading | Appearance | No marking defects | | | | | | | | | |
| | | Capacitance Change | Within $\pm 15\%$ | | | | | | | | | |
| | | D.F. | 0.05 max. | | | | | | | | | |
| | | I.R. | More than 1,000M Ω | | | | | | | | | |
| | | Dielectric Strength | In accordance with item No.4 | | | | | | | | | |
| | | | Apply the rated voltage at 40 $\pm 2^{\circ}\text{C}$ and relative humidity of 90 to 95% for 500 $\pm 2^{\circ}$ hrs. Remove and let sit for 24 ± 2 hrs. at room condition,* then measure. •Pretreatment Apply test voltage for 60 ± 5 min. at test temperature. Remove and let sit for 24 ± 2 hrs. at room condition.* | | | | | | | | | |

* "Room condition" Temperature: 15 to 35 $^{\circ}\text{C}$, Relative humidity: 45 to 75%, Atmospheric pressure: 86 to 106kPa

For General Purpose GRM/GRJ Series

Only for Applications

AC250V Type GA2 Series

Safety Standard Certified GA3 Series

Product Information

Chip Monolithic Ceramic Capacitors



Safety Standard Certified GA3 Series UL, IEC60384-14 Class X1/Y2 Type GC

■ Features

1. Chip monolithic ceramic capacitor (certified as conforming to safety standards) for AC lines.
2. A new monolithic structure for small, high capacitance capable of operating at high voltage levels.
3. Compared to lead type capacitors, this new capacitor is greatly downsized and low-profiled to 1/10 or less in volume, and 1/4 or less in height.
4. Type GC can be used as an X1-class and Y2-class capacitor, line-by-pass capacitor of UL1414.
5. +125 degree C guaranteed
6. Only for reflow soldering

■ Applications

1. Ideal for use as Y capacitor or X capacitor for various switching power supplies
2. Ideal for modem applications

Do not use these products in any Automotive Power train or Safety equipment including Battery chargers for Electric Vehicles and Plug-in Hybrids. Only Murata products clearly stipulated as "for Automotive use" can be used for automobile applications such as Power train and Safety equipment.

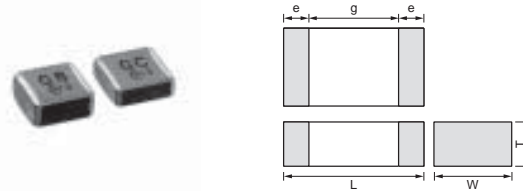

| Part Number | Dimensions (mm) | | | | |
|-------------|-----------------|----------|----------|--------|--------|
| | L | W | T | e min. | g min. |
| GA355D | 5.7 ±0.4 | 5.0 ±0.4 | 2.0 ±0.3 | 0.3 | 4.0 |

■ Standard Certification

| | Standard No. | Class | Rated Voltage |
|-------|--|--------------|--------------------|
| UL | UL1414 | Line By-pass | AC250V (r.m.s.) |
| VDE | IEC 60384-14 EN 60384-14 | X1, Y2 | |
| BSI | EN 60065 (14.2) IEC 60384-14 EN 60384-14 | | |
| SEMKO | IEC 60384-14 EN 60384-14 | | |
| ESTI | EN 60065 IEC 60384-14 | | |

| Part Number | Rated Voltage (V) | TC Code (Standard) | Capacitance (pF) | Length L (mm) | Width W (mm) | Thickness T (mm) | Electrode g min. (mm) | Electrode e (mm) |
|--------------------|-------------------|--------------------|------------------|---------------|--------------|------------------|-----------------------|------------------|
| GA355DR7GC101KY02L | AC250 (r.m.s.) | X7R (EIA) | 100 ±10% | 5.7 | 5.0 | 2.0 | 4.0 | 0.3 min. |
| GA355DR7GC151KY02L | AC250 (r.m.s.) | X7R (EIA) | 150 ±10% | 5.7 | 5.0 | 2.0 | 4.0 | 0.3 min. |
| GA355DR7GC221KY02L | AC250 (r.m.s.) | X7R (EIA) | 220 ±10% | 5.7 | 5.0 | 2.0 | 4.0 | 0.3 min. |
| GA355DR7GC331KY02L | AC250 (r.m.s.) | X7R (EIA) | 330 ±10% | 5.7 | 5.0 | 2.0 | 4.0 | 0.3 min. |

For General Purpose GRM/GRJ Series

Only for Applications

AC250V Type GA2 Series

Safety Standard Certified GA3 Series

Product Information

Chip Monolithic Ceramic Capacitors



Safety Standard Certified GA3 Series IEC60384-14 Class Y2, X1/Y2 Type GF

■ Features

1. Available for equipment based on IEC/EN60950 and UL1950. Besides, the GA352/355 types are available for equipment based on IEC/EN60065, UL1492, and UL6500.
2. Type GF can be used as a Y2-class capacitor.
3. A new monolithic structure for small, high capacitance capable of operating at high voltage levels.
4. +125 degree C guaranteed
5. Only for reflow soldering

■ Applications

1. Ideal for use on line filters and couplings for DAA modems without transformers
2. Ideal for use on line filters for information equipment
3. Ideal for use as Y capacitor or X capacitor for various switching power supplies (GA352/355 types only)

Do not use these products in any Automotive Power train or Safety equipment including Battery chargers for Electric Vehicles and Plug-in Hybrids. Only Murata products clearly stipulated as "for Automotive use" can be used for automobile applications such as Power train and Safety equipment.

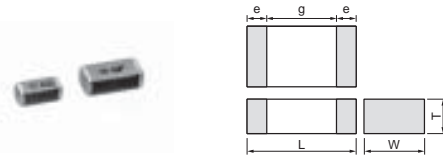

| Part Number | Dimensions (mm) | | | | |
|-------------|-----------------|----------|--------------|--------|--------|
| | L | W | T | e min. | g min. |
| GA342A | 4.5 ±0.3 | 2.0 ±0.2 | 1.0 +0, -0.3 | 0.3 | 2.5 |
| GA342D | | | 2.0 ±0.2 | | |
| GA342Q | | | 1.5 +0, -0.3 | | |
| GA352Q | 5.7 ±0.4 | 2.8 ±0.3 | 1.5 +0, -0.3 | | 4.0 |
| GA355D | | | 2.0 +0, -0.3 | | |
| GA355Q | | | 1.5 +0, -0.3 | | |

■ Standard Certification

| | Standard No. | Class | Status of Certification | | Rated Voltage |
|-------|--------------|--------|-------------------------|---------------------------|---------------|
| | | | Size : 4.5x2.0mm | Size : 5.7x2.8mm and over | |
| UL | UL1414 | X1, Y2 | — | ⊙ | AC250V |
| | UL 60950-1 | — | ⊙ | — | |
| VDE | IEC 60384-14 | X1, Y2 | — | ⊙ | (r.m.s.) |
| SEMKO | EN 60384-14 | Y2 | ⊙ | ⊙ | |

Applications

| Size | Switching power supplies | Communication network devices such as a modem |
|--------------------|--------------------------|---|
| 4.5x2.0mm | — | ⊙ |
| 5.7x2.8mm and over | ⊙ | ⊙ |

| Part Number | Rated Voltage (V) | TC Code (Standard) | Capacitance (pF) | Length L (mm) | Width W (mm) | Thickness T (mm) | Electrode g min. (mm) | Electrode e (mm) |
|--------------------|-------------------|--------------------|------------------|---------------|--------------|------------------|-----------------------|------------------|
| GA342D1XGF100JY02L | AC250 (r.m.s.) | SL (JIS) | 10 ±5% | 4.5 | 2.0 | 2.0 | 2.5 | 0.3 min. |
| GA342D1XGF120JY02L | AC250 (r.m.s.) | SL (JIS) | 12 ±5% | 4.5 | 2.0 | 2.0 | 2.5 | 0.3 min. |
| GA342D1XGF150JY02L | AC250 (r.m.s.) | SL (JIS) | 15 ±5% | 4.5 | 2.0 | 2.0 | 2.5 | 0.3 min. |
| GA342D1XGF180JY02L | AC250 (r.m.s.) | SL (JIS) | 18 ±5% | 4.5 | 2.0 | 2.0 | 2.5 | 0.3 min. |
| GA342D1XGF220JY02L | AC250 (r.m.s.) | SL (JIS) | 22 ±5% | 4.5 | 2.0 | 2.0 | 2.5 | 0.3 min. |
| GA342A1XGF270JW31L | AC250 (r.m.s.) | SL (JIS) | 27 ±5% | 4.5 | 2.0 | 1.0 | 2.5 | 0.3 min. |
| GA342A1XGF330JW31L | AC250 (r.m.s.) | SL (JIS) | 33 ±5% | 4.5 | 2.0 | 1.0 | 2.5 | 0.3 min. |
| GA342A1XGF390JW31L | AC250 (r.m.s.) | SL (JIS) | 39 ±5% | 4.5 | 2.0 | 1.0 | 2.5 | 0.3 min. |
| GA342A1XGF470JW31L | AC250 (r.m.s.) | SL (JIS) | 47 ±5% | 4.5 | 2.0 | 1.0 | 2.5 | 0.3 min. |
| GA342A1XGF560JW31L | AC250 (r.m.s.) | SL (JIS) | 56 ±5% | 4.5 | 2.0 | 1.0 | 2.5 | 0.3 min. |
| GA342A1XGF680JW31L | AC250 (r.m.s.) | SL (JIS) | 68 ±5% | 4.5 | 2.0 | 1.0 | 2.5 | 0.3 min. |
| GA342A1XGF820JW31L | AC250 (r.m.s.) | SL (JIS) | 82 ±5% | 4.5 | 2.0 | 1.0 | 2.5 | 0.3 min. |
| GA342QR7GF101KW01L | AC250 (r.m.s.) | X7R (EIA) | 100 ±10% | 4.5 | 2.0 | 1.5 | 2.5 | 0.3 min. |
| GA342QR7GF151KW01L | AC250 (r.m.s.) | X7R (EIA) | 150 ±10% | 4.5 | 2.0 | 1.5 | 2.5 | 0.3 min. |
| GA342DR7GF221KW02L | AC250 (r.m.s.) | X7R (EIA) | 220 ±10% | 4.5 | 2.0 | 2.0 | 2.5 | 0.3 min. |
| GA342DR7GF331KW02L | AC250 (r.m.s.) | X7R (EIA) | 330 ±10% | 4.5 | 2.0 | 2.0 | 2.5 | 0.3 min. |
| GA342QR7GF471KW01L | AC250 (r.m.s.) | X7R (EIA) | 470 ±10% | 4.5 | 2.0 | 1.5 | 2.5 | 0.3 min. |
| GA352QR7GF471KW01L | AC250 (r.m.s.) | X7R (EIA) | 470 ±10% | 5.7 | 2.8 | 1.5 | 4.0 | 0.3 min. |
| GA342QR7GF681KW01L | AC250 (r.m.s.) | X7R (EIA) | 680 ±10% | 4.5 | 2.0 | 1.5 | 2.5 | 0.3 min. |
| GA352QR7GF681KW01L | AC250 (r.m.s.) | X7R (EIA) | 680 ±10% | 5.7 | 2.8 | 1.5 | 4.0 | 0.3 min. |
| GA342DR7GF102KW02L | AC250 (r.m.s.) | X7R (EIA) | 1000 ±10% | 4.5 | 2.0 | 2.0 | 2.5 | 0.3 min. |
| GA352QR7GF102KW01L | AC250 (r.m.s.) | X7R (EIA) | 1000 ±10% | 5.7 | 2.8 | 1.5 | 4.0 | 0.3 min. |

Continued on the following page.

Continued from the preceding page.

| Part Number | Rated Voltage (V) | TC Code (Standard) | Capacitance (pF) | Length L (mm) | Width W (mm) | Thickness T (mm) | Electrode g min. (mm) | Electrode e (mm) |
|---------------------------|-------------------|--------------------|------------------|---------------|--------------|------------------|-----------------------|------------------|
| GA352QR7GF152KW01L | AC250 (r.m.s.) | X7R (EIA) | 1500 ±10% | 5.7 | 2.8 | 1.5 | 4.0 | 0.3 min. |
| GA355QR7GF182KW01L | AC250 (r.m.s.) | X7R (EIA) | 1800 ±10% | 5.7 | 5.0 | 1.5 | 4.0 | 0.3 min. |
| GA355QR7GF222KW01L | AC250 (r.m.s.) | X7R (EIA) | 2200 ±10% | 5.7 | 5.0 | 1.5 | 4.0 | 0.3 min. |
| GA355QR7GF332KW01L | AC250 (r.m.s.) | X7R (EIA) | 3300 ±10% | 5.7 | 5.0 | 1.5 | 4.0 | 0.3 min. |
| GA355DR7GF472KW01L | AC250 (r.m.s.) | X7R (EIA) | 4700 ±10% | 5.7 | 5.0 | 2.0 | 4.0 | 0.3 min. |

For General Purpose GRM/GRJ Series

Only for Applications

AC250V Type GA2 Series

Safety Standard Certified GA3 Series

Product Information

Chip Monolithic Ceramic Capacitors



Safety Standard Certified GA3 Series IEC60384-14 Class Y3 Type GD

■ Features

1. Available for equipment based on IEC/EN60950 and UL1950.
2. Type GD can be used as a Y3-class capacitor.
3. A new monolithic structure for small, high capacitance capable of operating at high voltage levels.
4. +125 degree C guaranteed
5. Only for reflow soldering

■ Applications

1. Ideal for use on line filters and couplings for DAA modems without transformers
2. Ideal for use on line filters for information equipment

Do not use these products in any Automotive Power train or Safety equipment including Battery chargers for Electric Vehicles and Plug-in Hybrids. Only Murata products clearly stipulated as "for Automotive use" can be used for automobile applications such as Power train and Safety equipment.

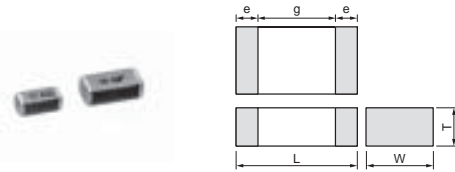

| Part Number | Dimensions (mm) | | | | |
|-------------|-----------------|----------|--------------|--------|--------|
| | L | W | T | e min. | g min. |
| GA342A | 4.5 ±0.3 | 2.0 ±0.2 | 1.0 +0, -0.3 | 0.3 | 2.5 |
| GA342D | | | 2.0 ±0.2 | | |
| GA342Q | | | 1.5 +0, -0.3 | | |
| GA343D | 4.5 ±0.4 | 3.2 ±0.3 | 2.0 +0, -0.3 | | |
| GA343Q | | | 1.5 +0, -0.3 | | |

■ Standard Certification

| | Standard No. | Class | Rated Voltage |
|-------|-----------------------------|-------|----------------|
| UL | UL 60950-1 | Y3 | AC250V(r.m.s.) |
| SEMKO | IEC 60384-14 EN 60384-14 | | |

Applications

| Size | Switching power supplies | Communication network devices such as a modem |
|---------------------|--------------------------|---|
| 4.5×3.2mm and under | — | ⊙ |

| Part Number | Rated Voltage (V) | TC Code (Standard) | Capacitance (pF) | Length L (mm) | Width W (mm) | Thickness T (mm) | Electrode g min. (mm) | Electrode e (mm) |
|--------------------|-------------------|--------------------|------------------|---------------|--------------|------------------|-----------------------|------------------|
| GA342D1XGD100JY02L | AC250 (r.m.s.) | SL (JIS) | 10 ±5% | 4.5 | 2.0 | 2.0 | 2.5 | 0.3 min. |
| GA342D1XGD120JY02L | AC250 (r.m.s.) | SL (JIS) | 12 ±5% | 4.5 | 2.0 | 2.0 | 2.5 | 0.3 min. |
| GA342D1XGD150JY02L | AC250 (r.m.s.) | SL (JIS) | 15 ±5% | 4.5 | 2.0 | 2.0 | 2.5 | 0.3 min. |
| GA342D1XGD180JY02L | AC250 (r.m.s.) | SL (JIS) | 18 ±5% | 4.5 | 2.0 | 2.0 | 2.5 | 0.3 min. |
| GA342D1XGD220JY02L | AC250 (r.m.s.) | SL (JIS) | 22 ±5% | 4.5 | 2.0 | 2.0 | 2.5 | 0.3 min. |
| GA342A1XGD270JW31L | AC250 (r.m.s.) | SL (JIS) | 27 ±5% | 4.5 | 2.0 | 1.0 | 2.5 | 0.3 min. |
| GA342A1XGD330JW31L | AC250 (r.m.s.) | SL (JIS) | 33 ±5% | 4.5 | 2.0 | 1.0 | 2.5 | 0.3 min. |
| GA342A1XGD390JW31L | AC250 (r.m.s.) | SL (JIS) | 39 ±5% | 4.5 | 2.0 | 1.0 | 2.5 | 0.3 min. |
| GA342A1XGD470JW31L | AC250 (r.m.s.) | SL (JIS) | 47 ±5% | 4.5 | 2.0 | 1.0 | 2.5 | 0.3 min. |
| GA342A1XGD560JW31L | AC250 (r.m.s.) | SL (JIS) | 56 ±5% | 4.5 | 2.0 | 1.0 | 2.5 | 0.3 min. |
| GA342A1XGD680JW31L | AC250 (r.m.s.) | SL (JIS) | 68 ±5% | 4.5 | 2.0 | 1.0 | 2.5 | 0.3 min. |
| GA342A1XGD820JW31L | AC250 (r.m.s.) | SL (JIS) | 82 ±5% | 4.5 | 2.0 | 1.0 | 2.5 | 0.3 min. |
| GA342QR7GD101KW01L | AC250 (r.m.s.) | X7R (EIA) | 100 ±10% | 4.5 | 2.0 | 1.5 | 2.5 | 0.3 min. |
| GA342QR7GD151KW01L | AC250 (r.m.s.) | X7R (EIA) | 150 ±10% | 4.5 | 2.0 | 1.5 | 2.5 | 0.3 min. |
| GA342QR7GD221KW01L | AC250 (r.m.s.) | X7R (EIA) | 220 ±10% | 4.5 | 2.0 | 1.5 | 2.5 | 0.3 min. |
| GA342QR7GD331KW01L | AC250 (r.m.s.) | X7R (EIA) | 330 ±10% | 4.5 | 2.0 | 1.5 | 2.5 | 0.3 min. |
| GA342QR7GD471KW01L | AC250 (r.m.s.) | X7R (EIA) | 470 ±10% | 4.5 | 2.0 | 1.5 | 2.5 | 0.3 min. |
| GA342QR7GD681KW01L | AC250 (r.m.s.) | X7R (EIA) | 680 ±10% | 4.5 | 2.0 | 1.5 | 2.5 | 0.3 min. |
| GA342QR7GD102KW01L | AC250 (r.m.s.) | X7R (EIA) | 1000 ±10% | 4.5 | 2.0 | 1.5 | 2.5 | 0.3 min. |
| GA342QR7GD152KW01L | AC250 (r.m.s.) | X7R (EIA) | 1500 ±10% | 4.5 | 2.0 | 1.5 | 2.5 | 0.3 min. |
| GA343QR7GD182KW01L | AC250 (r.m.s.) | X7R (EIA) | 1800 ±10% | 4.5 | 3.2 | 1.5 | 2.5 | 0.3 min. |
| GA343QR7GD222KW01L | AC250 (r.m.s.) | X7R (EIA) | 2200 ±10% | 4.5 | 3.2 | 1.5 | 2.5 | 0.3 min. |
| GA343DR7GD472KW01L | AC250 (r.m.s.) | X7R (EIA) | 4700 ±10% | 4.5 | 3.2 | 2.0 | 2.5 | 0.3 min. |

Chip Monolithic Ceramic Capacitors



Safety Standard Certified GA3 Series IEC60384-14 Class X2 Type GB

■ Features

1. Type GB can be used as an X2-class capacitor.
2. Chip monolithic ceramic capacitor (certified as conforming to safety standards) for AC lines.
3. A new monolithic structure for small, high capacitance capable of operating at high voltage levels.
4. Compared to lead type capacitors, this new capacitor is greatly downsized and low-profiled to 1/10 or less in volume, and 1/4 or less in height.
5. +125 degree C guaranteed
6. Only for reflow soldering

■ Applications

Ideal for use as X capacitor for various switching power supplies

Do not use these products in any Automotive Power train or Safety equipment including Battery chargers for Electric Vehicles and Plug-in Hybrids. Only Murata products clearly stipulated as "for Automotive use" can be used for automobile applications such as Power train and Safety equipment.

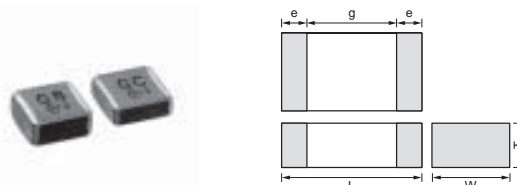

| Part Number | Dimensions (mm) | | | | |
|-------------|-----------------|----------|-------------|--------|--------|
| | L | W | T | e min. | g min. |
| GA355Q | 5.7 ±0.4 | 5.0 ±0.4 | 1.5 +0,-0.3 | 0.3 | 3.0 |
| GA355D | | | 2.0 +0,-0.3 | | |
| GA355E | | | 2.5 +0,-0.3 | | |
| GA355X | | | 2.9 +0,-0.4 | | |

■ Standard Certification

| | Standard No. | Class | Rated Voltage |
|-------|-----------------------------|-------|--------------------|
| VDE | IEC 60384-14 EN 60384-14 | X2 | AC250V (r.m.s.) |
| SEMKO | | | |
| ESTI | | | |

| Part Number | Rated Voltage (V) | TC Code (Standard) | Capacitance (pF) | Length L (mm) | Width W (mm) | Thickness T (mm) | Electrode g min. (mm) | Electrode e (mm) |
|--------------------|-------------------|--------------------|------------------|---------------|--------------|------------------|-----------------------|------------------|
| GA355QR7GB103KW01L | AC250 (r.m.s.) | X7R (EIA) | 10000 ±10% | 5.7 | 5.0 | 1.5 | 3.0 | 0.3 min. |
| GA355QR7GB153KW01L | AC250 (r.m.s.) | X7R (EIA) | 15000 ±10% | 5.7 | 5.0 | 1.5 | 3.0 | 0.3 min. |
| GA355DR7GB223KW01L | AC250 (r.m.s.) | X7R (EIA) | 22000 ±10% | 5.7 | 5.0 | 2.0 | 3.0 | 0.3 min. |
| GA355ER7GB333KW01L | AC250 (r.m.s.) | X7R (EIA) | 33000 ±10% | 5.7 | 5.0 | 2.5 | 3.0 | 0.3 min. |
| GA355ER7GB473KW01L | AC250 (r.m.s.) | X7R (EIA) | 47000 ±10% | 5.7 | 5.0 | 2.5 | 3.0 | 0.3 min. |
| GA355XR7GB563KW06L | AC250 (r.m.s.) | X7R (EIA) | 56000 ±10% | 5.7 | 5.0 | 2.9 | 3.0 | 0.3 min. |

For General Purpose GRM/GRJ Series

Only for Applications

AC250V Type GA2 Series

Safety Standard Certified GA3 Series

Product Information

GA3 Series Specifications and Test Methods

For General Purpose GRM/GRJ Series

Only for Applications

AC250V Type GA2 Series

Safety Standard Certified GA3 Series

Product Information

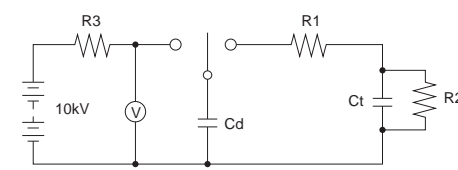
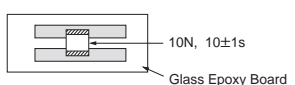
| No. | Item | Specifications | Test Method | | | | | | | | | | | | | | | | | | | | |
|--------------|---|---|--|--------------------|-----|-------------|---------|----------------------------|---------------------|--|--|------|------------------|---|--------------------------|---|------------------------|---|--------------------------|---|------------------------|---|--------------------------|
| 1 | Operating Temperature Range | -55 to +125°C | — | | | | | | | | | | | | | | | | | | | | |
| 2 | Appearance | No defects or abnormalities | Visual inspection | | | | | | | | | | | | | | | | | | | | |
| 3 | Dimensions | Within the specified dimensions | Using calipers and micrometers | | | | | | | | | | | | | | | | | | | | |
| 4 | Dielectric Strength | No defects or abnormalities | No failure should be observed when voltage in the table is applied between the terminations for 60±1 sec., provided the charge/discharge current is less than 50mA. <table border="1" style="margin-left: auto; margin-right: auto;"> <thead> <tr> <th colspan="2">Test Voltage</th> </tr> </thead> <tbody> <tr> <td>Type GB</td> <td>DC1075V</td> </tr> <tr> <td>Type GC/GD</td> <td>AC1500V (r.m.s.)</td> </tr> <tr> <td>Type GF</td> <td>AC2000V (r.m.s.)</td> </tr> </tbody> </table> | Test Voltage | | Type GB | DC1075V | Type GC/GD | AC1500V (r.m.s.) | Type GF | AC2000V (r.m.s.) | | | | | | | | | | | | |
| Test Voltage | | | | | | | | | | | | | | | | | | | | | | | |
| Type GB | DC1075V | | | | | | | | | | | | | | | | | | | | | | |
| Type GC/GD | AC1500V (r.m.s.) | | | | | | | | | | | | | | | | | | | | | | |
| Type GF | AC2000V (r.m.s.) | | | | | | | | | | | | | | | | | | | | | | |
| 5 | Pulse Voltage (Application: Type GD/GF) | No self healing breakdowns or flash-overs have taken place in the capacitor. | 10 impulses of alternating polarity are subjected. (5 impulses for each polarity) The interval between impulses is 60 sec. Applied Pulse: 1.2/50µs Applied Voltage: 2.5kVo-p | | | | | | | | | | | | | | | | | | | | |
| 6 | Insulation Resistance (I.R.) | More than 6,000MΩ | The insulation resistance should be measured with DC500±50V and within 60±5 sec. of charging. | | | | | | | | | | | | | | | | | | | | |
| 7 | Capacitance | Within the specified tolerance | | | | | | | | | | | | | | | | | | | | | |
| 8 | Dissipation Factor (D.F.) Q | <table border="1" style="margin-left: auto; margin-right: auto;"> <thead> <tr> <th>Char.</th> <th>Specification</th> </tr> </thead> <tbody> <tr> <td>X7R</td> <td>D.F. ≤0.025</td> </tr> <tr> <td rowspan="2">SL</td> <td>Q ≥ 400 + 20C*2 (C < 30pF)</td> </tr> <tr> <td>Q ≥ 1000 (C ≥ 30pF)</td> </tr> </tbody> </table> | Char. | Specification | X7R | D.F. ≤0.025 | SL | Q ≥ 400 + 20C*2 (C < 30pF) | Q ≥ 1000 (C ≥ 30pF) | The capacitance/Q/D.F. should be measured at a frequency of 1±0.2kHz (SL char.: 1±0.2MHz) and a voltage of AC1±0.2V (r.m.s.) | | | | | | | | | | | | | |
| Char. | Specification | | | | | | | | | | | | | | | | | | | | | | |
| X7R | D.F. ≤0.025 | | | | | | | | | | | | | | | | | | | | | | |
| SL | Q ≥ 400 + 20C*2 (C < 30pF) | | | | | | | | | | | | | | | | | | | | | | |
| | Q ≥ 1000 (C ≥ 30pF) | | | | | | | | | | | | | | | | | | | | | | |
| 9 | Capacitance Temperature Characteristics | <table border="1" style="margin-left: auto; margin-right: auto;"> <thead> <tr> <th>Char.</th> <th>Capacitance Change</th> </tr> </thead> <tbody> <tr> <td>X7R</td> <td>Within ±15%</td> </tr> </tbody> </table> Temperature characteristic guarantee is -55 to +125°C <table border="1" style="margin-left: auto; margin-right: auto;"> <thead> <tr> <th>Char.</th> <th>Temperature Coefficient</th> </tr> </thead> <tbody> <tr> <td>SL</td> <td>+350 to -1000ppm/°C</td> </tr> </tbody> </table> Temperature characteristic guarantee is +20 to +85°C | Char. | Capacitance Change | X7R | Within ±15% | Char. | Temperature Coefficient | SL | +350 to -1000ppm/°C | The capacitance measurement should be made at each step specified in the Table. <table border="1" style="margin-left: auto; margin-right: auto;"> <thead> <tr> <th>Step</th> <th>Temperature (°C)</th> </tr> </thead> <tbody> <tr> <td>1</td> <td>25±2 (20±2 for SL char.)</td> </tr> <tr> <td>2</td> <td>Min. Operating Temp.±3</td> </tr> <tr> <td>3</td> <td>25±2 (20±2 for SL char.)</td> </tr> <tr> <td>4</td> <td>Max. Operating Temp.±2</td> </tr> <tr> <td>5</td> <td>25±2 (20±2 for SL char.)</td> </tr> </tbody> </table> SL char. : The capacitance should be measured at even 85°C between step 3 and step 4. •Pretreatment for X7R char. Perform a heat treatment at 150±10°C for 60±5 min. and then let sit for 24±2 hrs. at room condition.*1 | Step | Temperature (°C) | 1 | 25±2 (20±2 for SL char.) | 2 | Min. Operating Temp.±3 | 3 | 25±2 (20±2 for SL char.) | 4 | Max. Operating Temp.±2 | 5 | 25±2 (20±2 for SL char.) |
| Char. | Capacitance Change | | | | | | | | | | | | | | | | | | | | | | |
| X7R | Within ±15% | | | | | | | | | | | | | | | | | | | | | | |
| Char. | Temperature Coefficient | | | | | | | | | | | | | | | | | | | | | | |
| SL | +350 to -1000ppm/°C | | | | | | | | | | | | | | | | | | | | | | |
| Step | Temperature (°C) | | | | | | | | | | | | | | | | | | | | | | |
| 1 | 25±2 (20±2 for SL char.) | | | | | | | | | | | | | | | | | | | | | | |
| 2 | Min. Operating Temp.±3 | | | | | | | | | | | | | | | | | | | | | | |
| 3 | 25±2 (20±2 for SL char.) | | | | | | | | | | | | | | | | | | | | | | |
| 4 | Max. Operating Temp.±2 | | | | | | | | | | | | | | | | | | | | | | |
| 5 | 25±2 (20±2 for SL char.) | | | | | | | | | | | | | | | | | | | | | | |
| 10 | Discharge Test (Application: Type GC) | Appearance | No defects or abnormalities | | | | | | | | | | | | | | | | | | | | |
| | | I.R. | More than 1,000MΩ | | | | | | | | | | | | | | | | | | | | |
| | | Dielectric Strength | In accordance with item No.4 | | | | | | | | | | | | | | | | | | | | |
| 11 | Adhesive Strength of Termination | No removal of the terminations or other defect should occur. | As in Fig., discharge is made 50 times at 5 sec. intervals from the capacitor (Cd) charged at DC voltage of specified.  Ct: Capacitor under test Cd: 0.001µF R1: 1,000Ω R2: 100MΩ R3: Surge resistance | | | | | | | | | | | | | | | | | | | | |
| | | | Solder the capacitor to the testing jig (glass epoxy board) shown in Fig. 1. Then apply 10N force in the direction of the arrow. The soldering should be done using the reflow method and should be conducted with care so that the soldering is uniform and free of defects such as heat shock.  Fig. 1 | | | | | | | | | | | | | | | | | | | | |

*1 "Room condition" Temperature: 15 to 35°C, Relative humidity: 45 to 75%, Atmospheric pressure: 86 to 106kPa
 *2 "C" expresses nominal capacitance value (pF).

Continued on the following page.

GA3 Series Specifications and Test Methods

Continued from the preceding page.

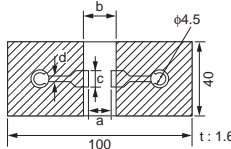
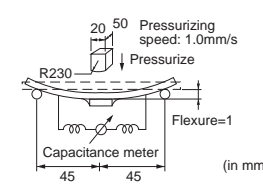
| No. | Item | Specifications | Test Method | | | | | | | | | | | | | | | | | | | | | | | |
|---------------------|---|--|---|---------------|--------------------|--------------|-------------|---|---|---|--------------|--------|---------|-----|-----|-----|-----|---------|-----|-----|-----|---------|-----|-----|-----|---------|
| 12 | Appearance | No defects or abnormalities | Solder the capacitor to the test jig (glass epoxy board). The capacitor should be subjected to a simple harmonic motion having a total amplitude of 1.5mm, the frequency being varied uniformly between the approximate limits of 10 and 55Hz. The frequency range, from 10 to 55Hz and return to 10Hz, should be traversed in approximately 1 min. This motion should be applied for a period of 2 hrs. in each of 3 mutually perpendicular directions (total of 6 hrs.). | | | | | | | | | | | | | | | | | | | | | | | |
| | Capacitance | Within the specified tolerance | | | | | | | | | | | | | | | | | | | | | | | | |
| | D.F. Q | <table border="1" style="width: 100%; border-collapse: collapse;"> <thead> <tr> <th style="width: 15%;">Char.</th> <th style="width: 85%;">Specification</th> </tr> </thead> <tbody> <tr> <td>X7R</td> <td>D.F. ≤ 0.025</td> </tr> <tr> <td>SL</td> <td>Q ≥ 400 + 20C*2 (C < 30pF) Q ≥ 1000 (C ≥ 30pF)</td> </tr> </tbody> </table> | Char. | Specification | X7R | D.F. ≤ 0.025 | SL | Q ≥ 400 + 20C*2 (C < 30pF) Q ≥ 1000 (C ≥ 30pF) | | | | | | | | | | | | | | | | | | |
| Char. | Specification | | | | | | | | | | | | | | | | | | | | | | | | | |
| X7R | D.F. ≤ 0.025 | | | | | | | | | | | | | | | | | | | | | | | | | |
| SL | Q ≥ 400 + 20C*2 (C < 30pF) Q ≥ 1000 (C ≥ 30pF) | | | | | | | | | | | | | | | | | | | | | | | | | |
| 13 | Deflection | No marking defects | Solder the capacitor to the testing jig (glass epoxy board) shown in Fig. 2. Then apply a force in the direction shown in Fig. 3. The soldering should be done using the reflow method and should be conducted with care so that the soldering is uniform and free of defects such as heat shock. | | | | | | | | | | | | | | | | | | | | | | | |
| | |  <p style="text-align: center;">Fig. 2</p> <table border="1" style="width: 100%; border-collapse: collapse;"> <thead> <tr> <th rowspan="2">L×W (mm)</th> <th colspan="4">Dimension (mm)</th> </tr> <tr> <th>a</th> <th>b</th> <th>c</th> <th>d</th> </tr> </thead> <tbody> <tr> <td>4.5×2.0</td> <td>3.5</td> <td>7.0</td> <td>2.4</td> <td rowspan="4" style="text-align: center; vertical-align: middle;">1.0</td> </tr> <tr> <td>4.5×3.2</td> <td>3.5</td> <td>7.0</td> <td>3.7</td> </tr> <tr> <td>5.7×2.8</td> <td>4.5</td> <td>8.0</td> <td>3.2</td> </tr> <tr> <td>5.7×5.0</td> <td>4.5</td> <td>8.0</td> <td>5.6</td> </tr> </tbody> </table> | | L×W (mm) | Dimension (mm) | | | | a | b | c | d | 4.5×2.0 | 3.5 | 7.0 | 2.4 | 1.0 | 4.5×3.2 | 3.5 | 7.0 | 3.7 | 5.7×2.8 | 4.5 | 8.0 | 3.2 | 5.7×5.0 |
| L×W (mm) | Dimension (mm) | | | | | | | | | | | | | | | | | | | | | | | | | |
| | a | b | c | d | | | | | | | | | | | | | | | | | | | | | | |
| 4.5×2.0 | 3.5 | 7.0 | 2.4 | 1.0 | | | | | | | | | | | | | | | | | | | | | | |
| 4.5×3.2 | 3.5 | 7.0 | 3.7 | | | | | | | | | | | | | | | | | | | | | | | |
| 5.7×2.8 | 4.5 | 8.0 | 3.2 | | | | | | | | | | | | | | | | | | | | | | | |
| 5.7×5.0 | 4.5 | 8.0 | 5.6 | | | | | | | | | | | | | | | | | | | | | | | |
| | |  <p style="text-align: center;">Fig. 3</p> | | | | | | | | | | | | | | | | | | | | | | | | |
| 14 | Solderability of Termination | 75% of the terminations are to be soldered evenly and continuously. | Immerse the capacitor in a solution of ethanol (JIS-K-8101) and rosin (JIS-K-5902) (25% rosin in weight proportion). Immerse in solder solution for 2±0.5 sec. Immersing speed: 25±2.5mm/s Temp. of solder: 245±5°C Lead Free Solder (Sn-3.0Ag-0.5Cu) 235±5°C H60A or H63A Eutectic Solder | | | | | | | | | | | | | | | | | | | | | | | |
| 15 | Appearance | No marking defects | Preheat the capacitor as in table. Immerse the capacitor in solder solution at 260±5°C for 10±1 sec. Let sit at room condition*1 for 24±2 hrs., then measure. •Immersing speed: 25±2.5mm/s •Pretreatment for X7R char. Perform a heat treatment at 150±18°C for 60±5 min. and then let sit for 24±2 hrs. at room condition.*1 | | | | | | | | | | | | | | | | | | | | | | | |
| | Capacitance Change | <table border="1" style="width: 100%; border-collapse: collapse;"> <thead> <tr> <th style="width: 15%;">Char.</th> <th style="width: 85%;">Capacitance Change</th> </tr> </thead> <tbody> <tr> <td>X7R</td> <td>Within ±10%</td> </tr> <tr> <td>SL</td> <td>Within ±2.5% or ±0.25pF (Whichever is larger)</td> </tr> </tbody> </table> | | Char. | Capacitance Change | X7R | Within ±10% | SL | Within ±2.5% or ±0.25pF (Whichever is larger) | | | | | | | | | | | | | | | | | |
| | Char. | Capacitance Change | | | | | | | | | | | | | | | | | | | | | | | | |
| | X7R | Within ±10% | | | | | | | | | | | | | | | | | | | | | | | | |
| SL | Within ±2.5% or ±0.25pF (Whichever is larger) | | | | | | | | | | | | | | | | | | | | | | | | | |
| I.R. | More than 1,000MΩ | | | | | | | | | | | | | | | | | | | | | | | | | |
| Dielectric Strength | In accordance with item No.4 | | | | | | | | | | | | | | | | | | | | | | | | | |
| | | *Preheating | <table border="1" style="width: 100%; border-collapse: collapse;"> <thead> <tr> <th style="width: 15%;">Step</th> <th style="width: 45%;">Temperature</th> <th style="width: 40%;">Time</th> </tr> </thead> <tbody> <tr> <td>1</td> <td>100 to 120°C</td> <td>1 min.</td> </tr> <tr> <td>2</td> <td>170 to 200°C</td> <td>1 min.</td> </tr> </tbody> </table> | Step | Temperature | Time | 1 | 100 to 120°C | 1 min. | 2 | 170 to 200°C | 1 min. | | | | | | | | | | | | | | |
| Step | Temperature | Time | | | | | | | | | | | | | | | | | | | | | | | | |
| 1 | 100 to 120°C | 1 min. | | | | | | | | | | | | | | | | | | | | | | | | |
| 2 | 170 to 200°C | 1 min. | | | | | | | | | | | | | | | | | | | | | | | | |

*1 "Room condition" Temperature: 15 to 35°C, Relative humidity: 45 to 75%, Atmospheric pressure: 86 to 106kPa
 *2 "C" expresses nominal capacitance value (pF).

Continued on the following page. ↗

For General Purpose GRM/GRJ Series

Only for Applications

AC250V Type GA2 Series

Safety Standard Certified GA3 Series

Product Information

GA3 Series Specifications and Test Methods

Continued from the preceding page.

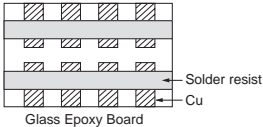
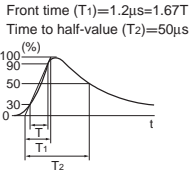
| No. | Item | Specifications | Test Method | | | | | | | | | | | | | | | |
|---------------------|--|--|--|--------------------|------------------|-------------|--|------------------------|--|----|------------|--------|---|------------------------|------|---|------------|--------|
| 16 | Appearance | No marking defects | Fix the capacitor to the supporting jig (glass epoxy board) shown in Fig. 4. Perform the 5 cycles according to the 4 heat treatments listed in the following table. Let sit for 24±2 hrs. at room condition,*1 then measure. <table border="1" style="margin: 10px auto;"> <thead> <tr> <th>Step</th> <th>Temperature (°C)</th> <th>Time (min.)</th> </tr> </thead> <tbody> <tr> <td>1</td> <td>Min. Operating Temp.±3</td> <td>30±3</td> </tr> <tr> <td>2</td> <td>Room Temp.</td> <td>2 to 3</td> </tr> <tr> <td>3</td> <td>Max. Operating Temp.±2</td> <td>30±3</td> </tr> <tr> <td>4</td> <td>Room Temp.</td> <td>2 to 3</td> </tr> </tbody> </table> <p>•Pretreatment for X7R char. Perform a heat treatment at 150±18°C for 60±5 min. and then let sit for 24±2 hrs. at room condition.*1</p>  <p style="text-align: center;">Fig. 4</p> | Step | Temperature (°C) | Time (min.) | 1 | Min. Operating Temp.±3 | 30±3 | 2 | Room Temp. | 2 to 3 | 3 | Max. Operating Temp.±2 | 30±3 | 4 | Room Temp. | 2 to 3 |
| | Step | Temperature (°C) | | Time (min.) | | | | | | | | | | | | | | |
| | 1 | Min. Operating Temp.±3 | | 30±3 | | | | | | | | | | | | | | |
| | 2 | Room Temp. | | 2 to 3 | | | | | | | | | | | | | | |
| | 3 | Max. Operating Temp.±2 | | 30±3 | | | | | | | | | | | | | | |
| 4 | Room Temp. | 2 to 3 | | | | | | | | | | | | | | | | |
| Capacitance Change | Char. | Capacitance Change | | | | | | | | | | | | | | | | |
| | X7R | Within ±15% | | | | | | | | | | | | | | | | |
| SL | Within ±2.5% or ±0.25pF (Whichever is larger) | | | | | | | | | | | | | | | | | |
| D.F. Q | Char. | Specification | | | | | | | | | | | | | | | | |
| | X7R | D.F. ≤0.05 | | | | | | | | | | | | | | | | |
| SL | Q≥400+20C*2 (C<30pF) Q≥1000 (C≥30pF) | | | | | | | | | | | | | | | | | |
| I.R. | More than 3,000MΩ | | | | | | | | | | | | | | | | | |
| Dielectric Strength | In accordance with item No.4 | | | | | | | | | | | | | | | | | |
| 17 | Appearance | No marking defects | Before this test, the test shown in the following is performed. -Item 11 Adhesive Strength of Termination (applied force is 5N) -Item 13 Deflection Let the capacitor sit at 40±2°C and relative humidity of 90 to 95% for 500±24 hrs. Remove and let sit for 24±2 hrs. at room condition,*1 then measure. •Pretreatment for X7R char. Perform a heat treatment at 150±18°C for 60±5 min. and then let sit for 24±2 hrs. at room condition.*1 | | | | | | | | | | | | | | | |
| | Capacitance Change | Char. | | Capacitance Change | | | | | | | | | | | | | | |
| | | X7R | | Within ±15% | | | | | | | | | | | | | | |
| | SL | Within ±5.0% or ±0.5pF (Whichever is larger) | | | | | | | | | | | | | | | | |
| | D.F. Q | Char. | | Specification | | | | | | | | | | | | | | |
| X7R | | D.F. ≤0.05 | | | | | | | | | | | | | | | | |
| SL | Q≥275+5/2C*2 (C<30pF) Q≥350 (C≥30pF) | | | | | | | | | | | | | | | | | |
| I.R. | More than 3,000MΩ | | | | | | | | | | | | | | | | | |
| Dielectric Strength | In accordance with item No.4 | | | | | | | | | | | | | | | | | |
| 18 | Appearance | No marking defects | Before this test, the test shown in the following is performed. -Item 11 Adhesive Strength of Termination (apply force is 5N) -Item 13 Deflection Impulse Voltage Each individual capacitor should be subjected to a 2.5kV (Type GC/GF: 5kV) Impulse (the voltage value means zero to peak) for three times. Then the capacitors are applied to life test.  <p style="font-size: small;">Front time (T₁)=1.2μs=1.67T Time to half-value (T₂)=50μs</p> | | | | | | | | | | | | | | | |
| | Capacitance Change | Char. | | Capacitance Change | | | | | | | | | | | | | | |
| | | X7R | | Within ±20% | | | | | | | | | | | | | | |
| | SL | Within ±3.0% or ±0.3pF (Whichever is larger) | | | | | | | | | | | | | | | | |
| | D.F. Q | Char. | | Specification | | | | | | | | | | | | | | |
| X7R | | D.F. ≤0.05 | | | | | | | | | | | | | | | | |
| SL | Q≥275+5/2C*2 (C<30pF) Q≥350 (C≥30pF) | | | | | | | | | | | | | | | | | |
| I.R. | More than 3,000MΩ | | | | | | | | | | | | | | | | | |
| Dielectric Strength | In accordance with item No.4 | | | | | | | | | | | | | | | | | |
| 18 | Life | More than 3,000MΩ | Apply voltage as in Table for 1,000 hrs. at 125±2°C, relative humidity 50% max. <table border="1" style="margin: 10px auto;"> <thead> <tr> <th>Type</th> <th>Applied Voltage</th> </tr> </thead> <tbody> <tr> <td>GB</td> <td>AC312.5V (r.m.s.), except that once each hour the voltage is increased to AC1,000V (r.m.s.) for 0.1 sec.</td> </tr> <tr> <td>GC</td> <td rowspan="3">AC425V (r.m.s.), except that once each hour the voltage is increased to AC1,000V (r.m.s.) for 0.1 sec.</td> </tr> <tr> <td>GF</td> </tr> <tr> <td>GD</td> </tr> </tbody> </table> | Type | Applied Voltage | GB | AC312.5V (r.m.s.), except that once each hour the voltage is increased to AC1,000V (r.m.s.) for 0.1 sec. | GC | AC425V (r.m.s.), except that once each hour the voltage is increased to AC1,000V (r.m.s.) for 0.1 sec. | GF | GD | | | | | | | |
| | | | Type | Applied Voltage | | | | | | | | | | | | | | |
| GB | AC312.5V (r.m.s.), except that once each hour the voltage is increased to AC1,000V (r.m.s.) for 0.1 sec. | | | | | | | | | | | | | | | | | |
| GC | AC425V (r.m.s.), except that once each hour the voltage is increased to AC1,000V (r.m.s.) for 0.1 sec. | | | | | | | | | | | | | | | | | |
| GF | | | | | | | | | | | | | | | | | | |
| GD | | | | | | | | | | | | | | | | | | |
| Dielectric Strength | In accordance with item No.4 | | | | | | | | | | | | | | | | | |

*1 "Room condition" Temperature: 15 to 35°C, Relative humidity: 45 to 75%, Atmospheric pressure: 86 to 106kPa
 *2 "C" expresses nominal capacitance value (pF).

Continued on the following page.

GA3 Series Specifications and Test Methods

Continued from the preceding page.

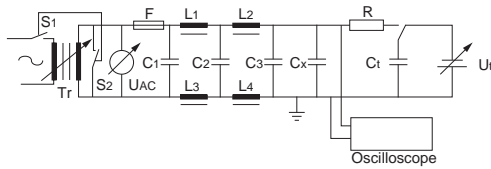
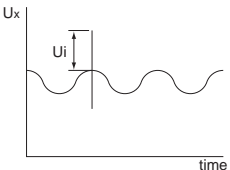
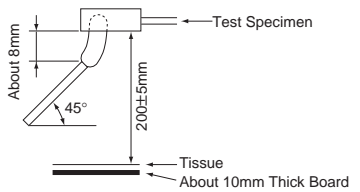
| No. | Item | Specifications | Test Method | | | |
|---------------------|------------------------------|---|--|---|----|--------|
| 19 | Appearance | No marking defects | Before this test, the test shown in the following is performed. -Item 11 Adhesive Strength of Termination (apply force is 5N) -Item 13 Deflection Apply the rated voltage at 40±2°C and relative humidity of 90 to 95% for 500±20 hrs. Remove and let sit for 24±2 hrs. at room condition,*1 then measure. •Pretreatment for X7R char. Perform a heat treatment at 150±10 °C for 60±5 min. and then let sit for 24±2 hrs. at room condition.*1 | | | |
| | Capacitance Change | Char. X7R | | Capacitance Change Within ±15% | | |
| | | SL | | Within ±5.0% or ±0.5pF (Whichever is larger) | | |
| | D.F. Q | Char. X7R | | Specification D.F. ≤0.05 | | |
| | | SL | | Q ≥ 275 + 5/2C*2 (C < 30pF) Q ≥ 350 (C ≥ 30pF) | | |
| I.R. | More than 3,000MΩ | | | | | |
| Dielectric Strength | In accordance with item No.4 | | | | | |
| 20 | Active Flammability | The cheesecloth should not be on fire. | The capacitor should be individually wrapped in at least one but not more than two complete layers of cheesecloth. The capacitor should be subjected to 20 discharges. The interval between successive discharges should be 5 sec. The UAC should be maintained for 2 min. after the last discharge. | | | |
| | | |  <p> C1,2 : 1μF±10% C3 : 0.033μF±5% 10kV L1 to 4 : 1.5mH±20% 16A Rod core choke Ct : 3μF±5% 10kV R : 100Ω±2% Cx : Capacitor under test UAC : UR±5% F : Fuse, Rated 16A UR : Rated Voltage Ux : Voltage applied to Ct </p>  <table border="1" data-bbox="1193 1081 1421 1165"> <thead> <tr> <th>Type</th> <th>Ui</th> </tr> </thead> <tbody> <tr> <td>GD, GB</td> <td>2.5kV</td> </tr> <tr> <td>GC, GF</td> <td>5kV</td> </tr> </tbody> </table> | Type | Ui | GD, GB |
| Type | Ui | | | | | |
| GD, GB | 2.5kV | | | | | |
| GC, GF | 5kV | | | | | |
| 21 | Passive Flammability | The burning time should not exceed 30 sec. The tissue paper should not ignite. | The capacitor under test should be held in the flame in the position which best promotes burning. Each specimen should be exposed to the flame only once. Time of exposure to flame: 30 sec. | | | |
| | | Length of flame : 12±1mm Gas burner : Length 35mm min. : Inside Dia. 0.5±0.1mm : Outside Dia. 0.9mm max. Gas : Butane gas Purity 95% min. |  | | | |

*1 "Room condition" Temperature: 15 to 35°C, Relative humidity: 45 to 75%, Atmospheric pressure: 86 to 106kPa

*2 "C" expresses nominal capacitance value (pF).

For General Purpose
GRM/GRJ Series

Only for Applications

AC250V Type
GA2 Series

Safety Standard
Certified GA3 Series

Product Information

For General Purpose
GRM/GRJ Series

Only for Applications

AC250V Type
GA2 Series

Safety Standard
Certified GA3 Series

Product Information
Reference Data

GRM/GRJ/GR4/GR7/GA2/GA3 Series Reference Data (Typical Example)

Capacitance - Temperature Characteristics

C0G/U2J/SL Characteristics

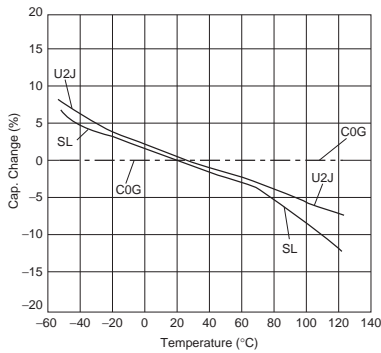

X7R Characteristics

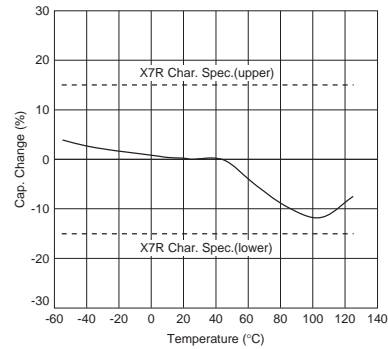

GR4 Series

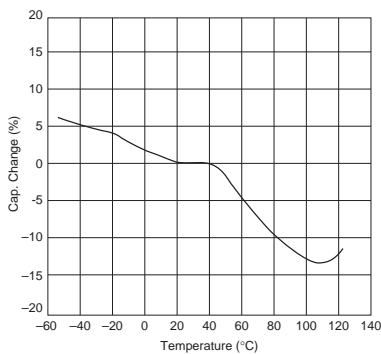

Impedance - Frequency Characteristics

GRM Series (C0G Char. 250V)

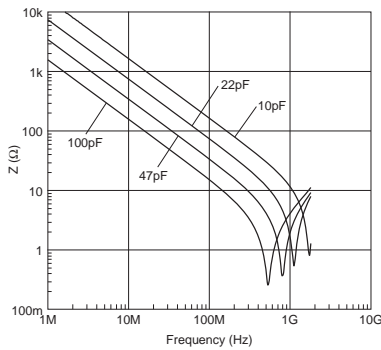

GRM Series (C0G Char. 630V)

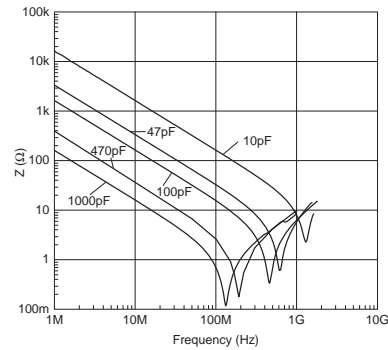

GRM Series (C0G Char. 1kV)

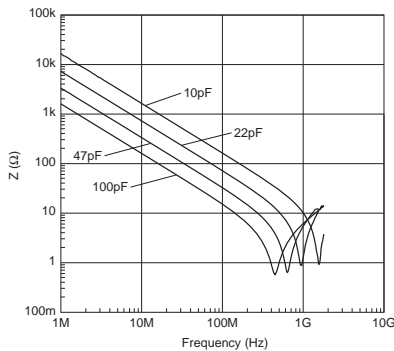

GRM Series (X7R Char. 250V)

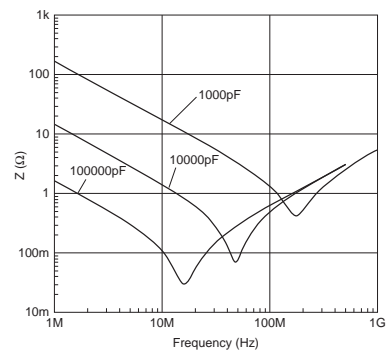

Continued on the following page.

GRM/GRJ/GR4/GR7/GA2/GA3 Series Reference Data (Typical Example)

Continued from the preceding page.

Impedance - Frequency Characteristics

GRM Series (X7R Char. 630V)

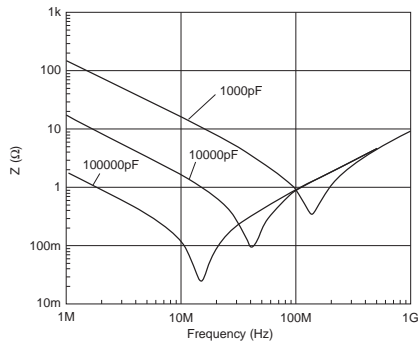

GRJ Series (X7R Char. 250V)

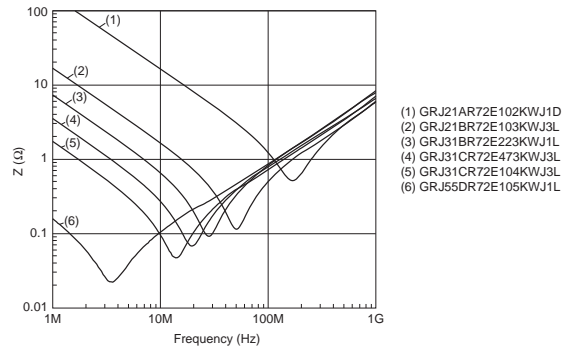

- (1) GRJ21AR72E102KWJ1D
- (2) GRJ21BR72E103KWJ3L
- (3) GRJ31BR72E223KWJ1L
- (4) GRJ31CR72E473KWJ3L
- (5) GRJ31DR72E104KWJ3L
- (6) GRJ55DR72E105KWJ1L

GRJ Series (X7R Char. 630V)

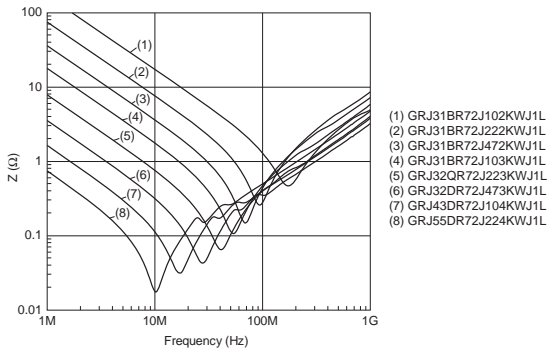

- (1) GRJ31BR72J102KWJ1L
- (2) GRJ31BR72J222KWJ1L
- (3) GRJ31BR72J472KWJ1L
- (4) GRJ31BR72J103KWJ1L
- (5) GRJ32QR72J223KWJ1L
- (6) GRJ32DR72J473KWJ1L
- (7) GRJ43DR72J104KWJ1L
- (8) GRJ55DR72J224KWJ1L

GR4 Series

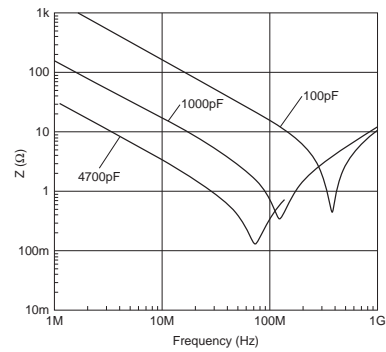

GA2 Series

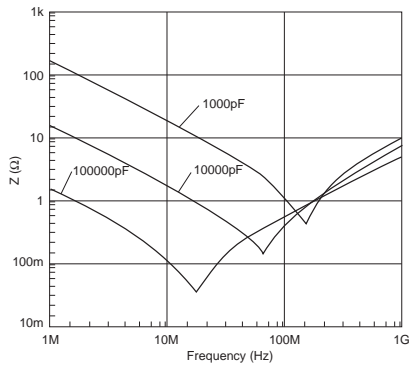

GA3 Series (Type GF)

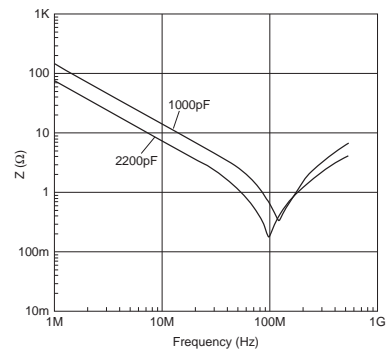

GA3 Series (Type GD)

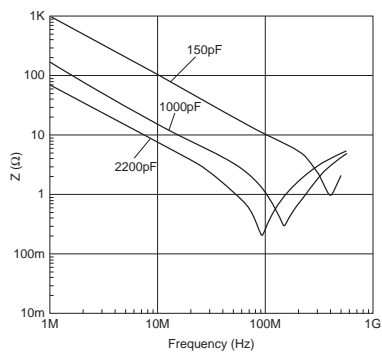

GA3 Series (Type GB)

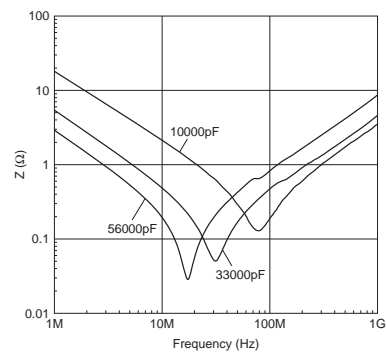

For General Purpose
 GRM/GRJ Series

Only for Applications

AC250V Type
 GA2 Series

Safety Standard
 Certified GA3 Series

Product Information
 Reference Data

Continued on the following page. ↗

GRM/GRJ/GR4/GR7/GA2/GA3 Series Reference Data (Typical Example)

For General Purpose
GRM/GRJ Series

Only for Applications

AC250V Type
GA2 Series

Safety Standard
Certified GA3 Series

Product Information
Reference Data

Continued from the preceding page.

Capacitance - AC Voltage Characteristics

GA3 Series (Type GF/GD, X7R Char.)

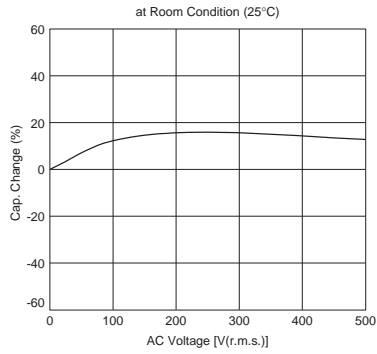

GA3 Series (Type GB)

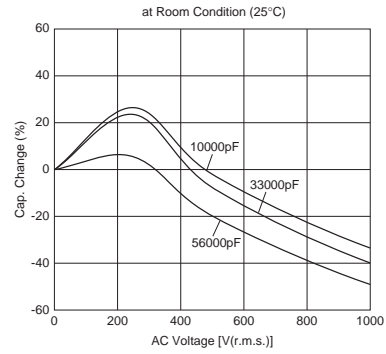

Capacitance - DC Bias Characteristics

GR7 Series

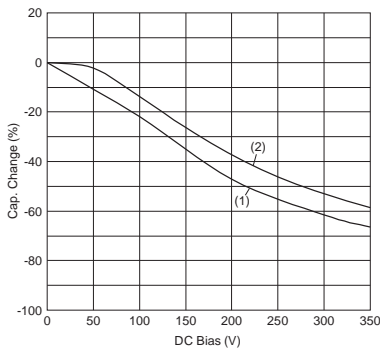

- (1) GR721AW0BB103KW01D
 GR721AW0BB153KW01D
 GR721BW0BB223KW03L
 GR731AW0BB223KW01D
 GR721BW0BB273KW03L
 GR731AW0BB273KW01D
 GR731AW0BB333KW01D

- (2) GR731AW0BB103KW01D
 GR731AW0BB153KW01D
 GR731BW0BB223KW01L
 GR731BW0BB333KW01L
 GR731CW0BB473KW03L

Package

Taping is the standard packaging method.

■ Minimum Quantity Guide

| Part Number | Dimensions (mm) | | | Quantity (pcs.) | | |
|---------------------------|-------------------|-----|------|-----------------|---------------|-------|
| | | | | ø180mm Reel | | |
| | L | W | T | Paper Tape | Embossed Tape | |
| Medium Voltage | GRM18 | 1.6 | 0.8 | 0.8 | 4,000 | - |
| | GRJ21/GRM21/GR721 | 2.0 | 1.25 | 1.0 | 4,000 | - |
| | | | | 1.25 | - | 3,000 |
| | GRJ31/GRM31/GR731 | 3.2 | 1.6 | 1.0 | 4,000 | - |
| | | | | 1.25 | - | 3,000 |
| | | | | 1.6 | - | 2,000 |
| | GRJ32/GRM32 | 3.2 | 2.5 | 1.0 | 4,000 | - |
| | | | | 1.25 | - | 3,000 |
| | | | | 1.5 | - | 2,000 |
| | | | | 2.0 | - | 1,000 |
| | GRM42/GR442 | 4.5 | 2.0 | 1.0 | - | 3,000 |
| | | | | 1.5 | - | 2,000 |
| GRJ43/GRM43/GR443 | 4.5 | 3.2 | 1.5 | - | 1,000 | |
| | | | 2.0 | - | 1,000 | |
| | | | 2.5 | - | 500 | |
| GRJ55/GRM55/GR455 | 5.7 | 5.0 | 2.0 | - | 1,000 | |
| AC250V | GA242 | 4.5 | 2.0 | 1.5 | - | 2,000 |
| | GA243 | 4.5 | 3.2 | 1.5 | - | 1,000 |
| | | | | 2.0 | - | 1,000 |
| GA255 | 5.7 | 5.0 | 2.0 | - | 1,000 | |
| Safety Std. Certification | GA342 | 4.5 | 2.0 | 1.0 | - | 3,000 |
| | | | | 1.5 | - | 2,000 |
| | | | | 2.0 | - | 2,000 |
| | GA343 | 4.5 | 3.2 | 1.5 | - | 1,000 |
| | | | | 2.0 | - | 1,000 |
| | GA352 | 5.7 | 2.8 | 1.5 | - | 1,000 |
| | GA355 | 5.7 | 5.0 | 1.5 | - | 1,000 |
| | | | | 2.0 | - | 1,000 |
| | | | | 2.5 | - | 500 |
| 2.7 | | | | - | 500 | |
| 2.9 | - | 500 | | | | |

For General Purpose
GRM/GRJ Series

Only for Applications

AC250V Type
GA2 Series

Safety Standard
Certified GA3 Series

Product Information
Package

■ Tape Carrier Packaging

(1) Appearance of Taping

① Embossed Tape

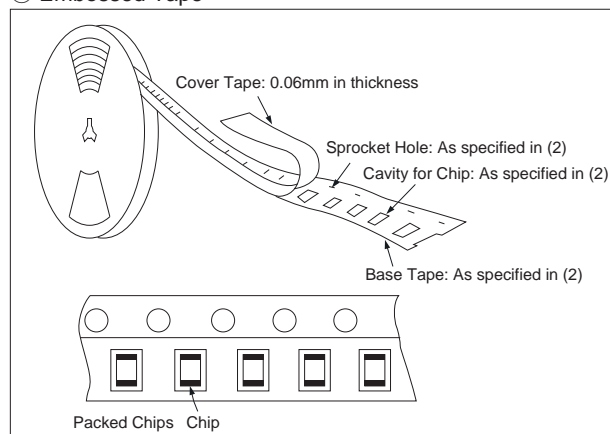

② Paper Tape

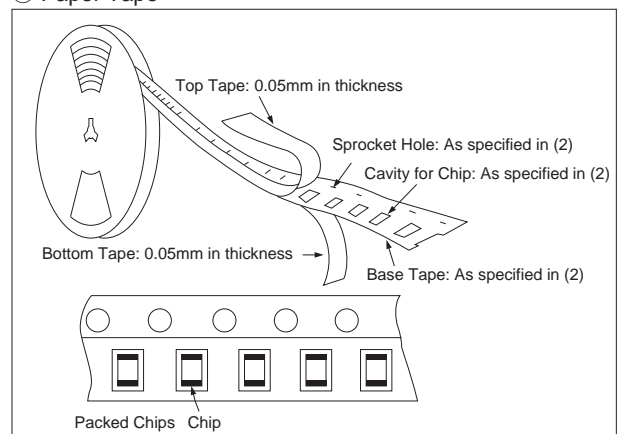

Continued on the following page. ↗

Package

Continued from the preceding page.

(2) Dimensions of Tape

① Embossed Tape

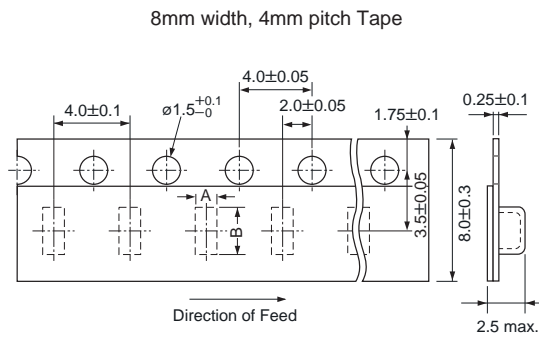

| Part Number | A* | B* |
|--|------|------|
| GRJ21/GRM21/GR721 (T≥1.25mm) | 1.45 | 2.25 |
| GRJ31/GRM31/GR731 (T≥1.25mm) | 2.0 | 3.6 |
| GRJ32/GRM32 (T≥1.25mm) | 2.9 | 3.6 |

*Nominal Value

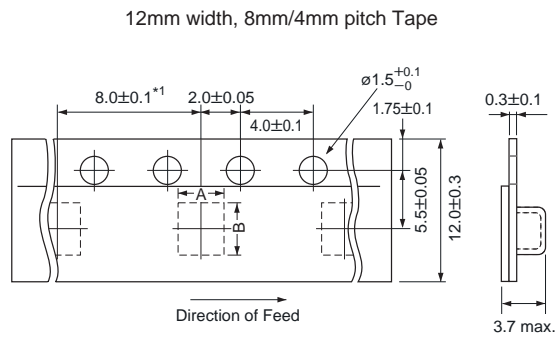

| Part Number | A* | B* |
|--------------------------------------|-----|-----|
| GRM42/GR442/GA242/GA342 | 2.5 | 5.1 |
| GRJ43/GRM43/GR443/GA243/GA343 | 3.6 | 4.9 |
| GA352 | 3.2 | 6.1 |
| GRJ55/GRM55/GR455/GA255/GA355 | 5.4 | 6.1 |

*1 4.0±0.1mm in case of GRM42/GR442/GA242/GA342

*Nominal Value

(in mm)

② Paper Tape

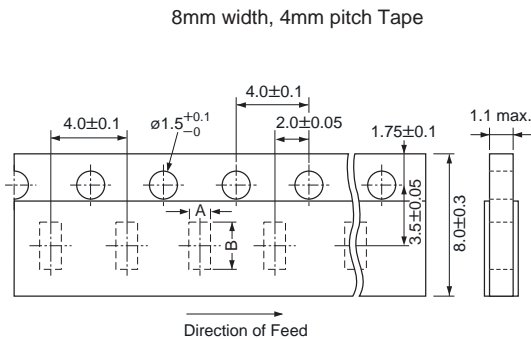

| Part Number | A* | B* |
|---------------------------------------|------|------|
| GRM18 | 1.05 | 1.85 |
| GRJ21/GRM21/GR721 (T=1.0mm) | 1.45 | 2.25 |
| GRM31/GR731 (T=1.0mm) | 2.0 | 3.6 |
| GRM32 (T=1.0mm) | 2.9 | 3.6 |

*Nominal Value
(in mm)

(3) Dimensions of Reel

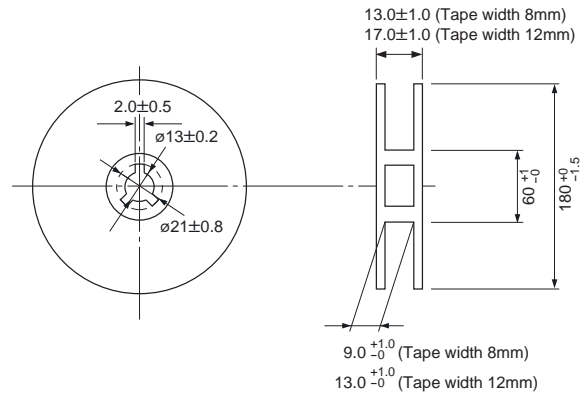

(in mm)

Continued on the following page. ↗

Package

Continued from the preceding page.

(4) Taping Method

- ① Tapes for capacitors are wound clockwise. The sprocket holes are to the right as the tape is pulled toward the user.
- ② Part of the leader and part of the empty tape should be attached to the end of the tape as shown at right.
- ③ The top tape or cover tape and base tape are not attached at the end of the tape for a minimum of 5 pitches.
- ④ Missing capacitors number within 0.1% of the number per reel or 1 pc, whichever is greater, and are not continuous.
- ⑤ The top tape or cover tape and bottom tape should not protrude beyond the edges of the tape and should not cover sprocket holes.
- ⑥ Cumulative tolerance of sprocket holes, 10 pitches: $\pm 0.3\text{mm}$.
- ⑦ Peeling off force: 0.1 to 0.6N in the direction shown at right.

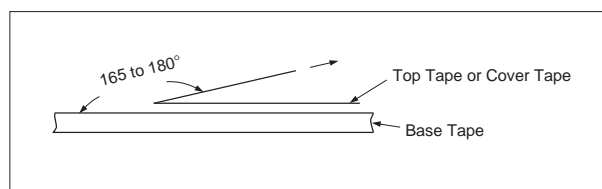
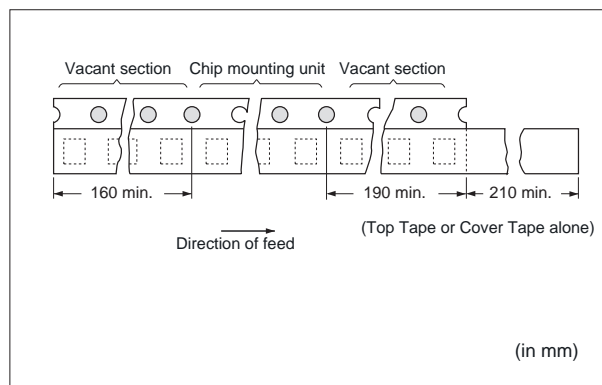

For General Purpose
 GRM/GRJ Series

Only for Applications

AC250V Type
 GA2 Series

Safety Standard
 Certified GA3 Series

Product Information
 Package

For General Purpose
GRM/GRJ Series

Only for Applications

AC250V Type
GA2 Series

Safety Standard
Certified GA3 Series

Product Information
△Caution

△Caution

■ Storage and Operating Conditions

Operating and storage environment

Do not use or store capacitors in a corrosive atmosphere, especially where chloride gas, sulfide gas, acid, alkali, salt or the like are present. In addition, avoid exposure to moisture. Before cleaning, bonding or molding this product, verify that these processes do not affect product quality by testing the performance of a cleaned, bonded or molded product in the intended equipment. Store the capacitors where the temperature and relative humidity do not exceed 5 to 40 degrees centigrade and 20 to 70%.

Use capacitors within 6 months of delivery.

Check the solderability after 6 months or more.

FAILURE TO FOLLOW THE ABOVE CAUTIONS MAY RESULT, WORST CASE, IN A SHORT CIRCUIT AND CAUSE FUMING OR PARTIAL DISPERSION WHEN THE PRODUCT IS USED.

■ Handling

1. Vibration and impact

Do not expose a capacitor to excessive shock or vibration during use.

2. Do not directly touch the chip capacitor, especially the ceramic body. Residue from hands/fingers may create a short circuit environment.

FAILURE TO FOLLOW THE ABOVE CAUTIONS MAY RESULT, WORST CASE, IN A SHORT CIRCUIT AND CAUSE FUMING OR PARTIAL DISPERSION WHEN THE PRODUCT IS USED.

Caution

■ **Caution (Rating)**

1. **Operating Voltage**

When DC-rated capacitors are to be used in AC or ripple current circuits, be sure to maintain the V_{p-p} value of the applied voltage or the V_{0-p} which contains DC bias within the rated voltage range.

When the voltage is applied to the circuit, starting or stopping may generate irregular voltage for a transit period because of resonance or switching. Be sure to use a capacitor with a rated voltage range that includes these irregular voltages.

When DC-rated capacitors are to be used in input circuits from a commercial power source (AC filter), be sure to use Safety Certified Capacitors because various regulations for withstanding voltage or impulses, established for all equipment, should be taken into consideration.

| Voltage | DC Voltage | DC+AC Voltage | AC Voltage | Pulse Voltage (1) | Pulse Voltage (2) |
|------------------------|------------|---------------|------------|-------------------|-------------------|
| Positional Measurement | | | | | |

2. **Operating Temperature, Self-generated Heat, and Load Reduction at High-frequency Voltage Condition**

Keep the surface temperature of a capacitor below the upper limit of its rated operating temperature range.

Be sure to take into account the heat generated by the capacitor itself. When the capacitor is used in a high-frequency voltage, pulse voltage, it may self-generate heat due to dielectric loss.

(1) In the case of X7R char.

Applied voltage should be the load such as self-generated heat is within 20°C on the condition of atmosphere temperature 25°C. When measuring, use a thermocouple of small thermal capacity -K of $\phi 0.1\text{mm}$ in conditions where the capacitor is not affected by radiant heat from other components or surrounding ambient fluctuations. Excessive heat may lead to deterioration of the capacitor's characteristics and reliability. (Never attempt to perform measurement with the cooling fan running. Otherwise, accurate measurement cannot be ensured.)

Continued on the following page.

For General Purpose
 GRM/GRJ Series

Only for Applications

AC250V Type
 GA2 Series

Safety Standard
 Certified GA3 Series

Product Information
 △Caution

Caution

Continued from the preceding page.

(2) In case of C0G, U2J char.

Due to the low self-heating characteristics of low-dissipation capacitors, the allowable electric power of these capacitors is generally much higher than that of X7R characteristic capacitors.

When a high frequency voltage that causes 20°C self-heating to the capacitor is applied, it will exceed the capacitor's allowable electric power.

The frequency of the applied sine wave voltage should be less than 500kHz (less than 100kHz in the case of rated voltage: DC3.15kV). The applied voltage should be less than the value shown in figure below.

In the case of non-sine wave that includes a harmonic frequency, please contact our sales representatives or product engineers. Excessive heat may lead to deterioration of the capacitor's characteristics and reliability. (Never attempt to perform measurement with the cooling fan running. Otherwise, accurate measurement cannot be ensured.)

<C0G char., Rated Voltage: DC3.15kV>

The capacitors less than 22pF can be applied maximum 4.0kV peak to peak at 100kHz or less only for the ballast or the resonance usage in the LCD backlight inverter circuit.

<Capacitor Selection Tool>

We are also offering free software/the capacitor selection tool: "Murata Medium Voltage Capacitors Selection Tool by Voltage Form," which will assist you in selecting a suitable capacitor.

The software can be downloaded from Murata's Website. (<http://www.murata.com/designlib/mmcsv/index.html>).

By inputting capacitance values and the applied voltage waveform of the specific capacitor series, this software will calculate the capacitor's power consumption and list suitable capacitors (non-sine wave is also available).

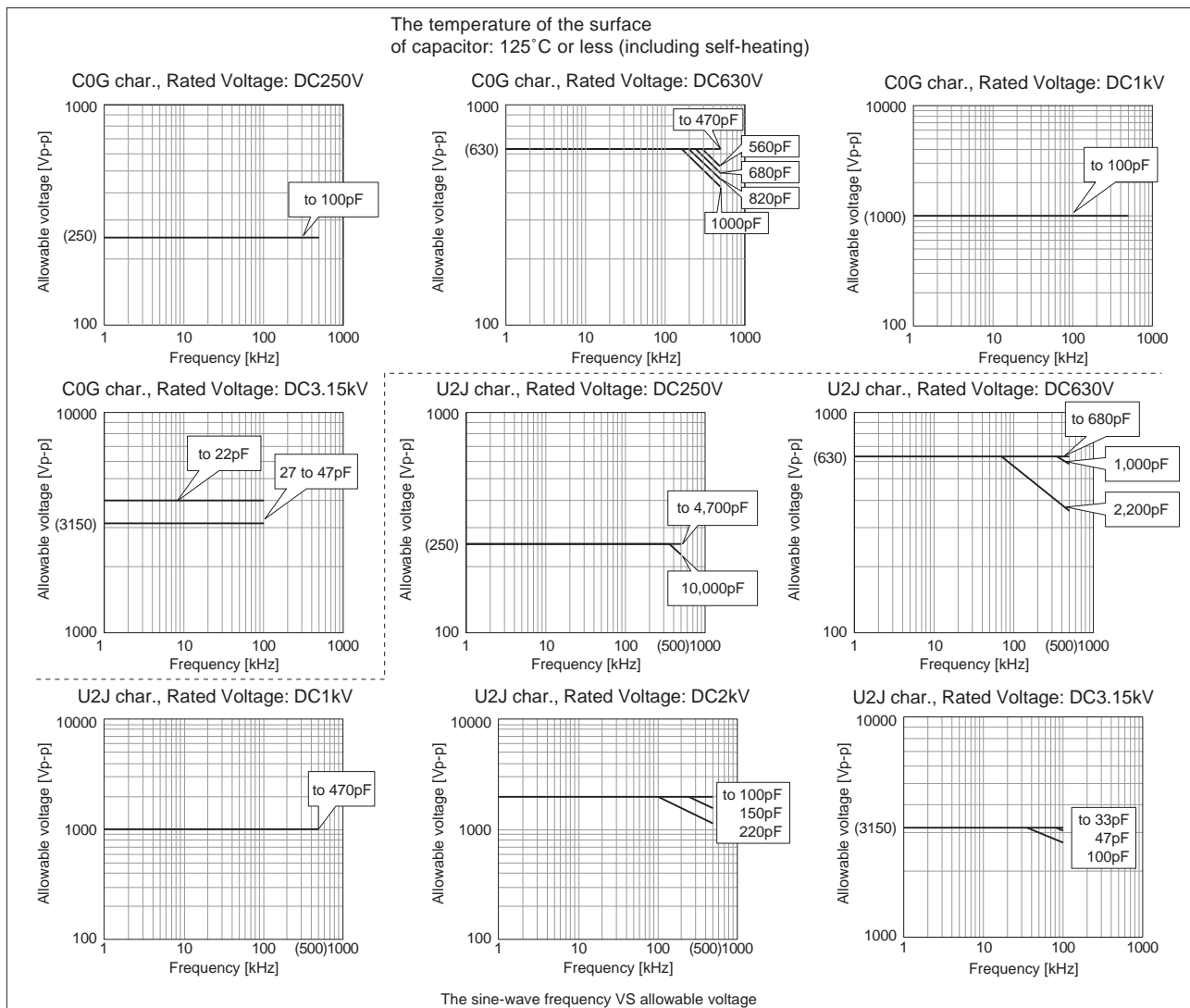

Continued on the following page.

Caution

Continued from the preceding page.

3. Fail-safe

Failure of a capacitor may result in a short circuit. Be sure to provide an appropriate fail-safe function such as a fuse on your product to help eliminate possible electric shock, fire, or fumes.

Please consider using fuses on each AC line if the capacitors are used between the AC input lines and earth (line bypass capacitors), to prepare for the worst case, such as a short circuit.

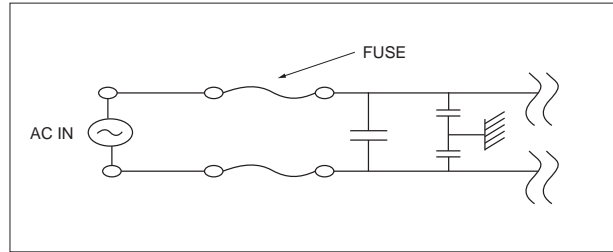

4. Test Condition for AC Withstanding Voltage

(1) Test Equipment

Tests for AC withstanding voltage should be made with equipment capable of creating a wave similar to a 50/60 Hz sine wave.

If the distorted sine wave or overload exceeding the specified voltage value is applied, a defect may be caused.

(2) Voltage Applied Method

The capacitor's leads or terminals should be firmly connected to the output of the withstanding voltage test equipment, and then the voltage should be raised from near zero to the test voltage. If the test voltage is applied directly to the capacitor without raising it from near zero, it should be applied with the zero cross.* At the end of the test time, the test voltage should be reduced to near zero, and then the capacitor's leads or terminals should be taken off the output of the withstanding voltage test equipment. If the test voltage is applied directly to the capacitor without raising it from near zero, surge voltage may occur and cause a defect.

*ZERO CROSS is the point where voltage sine wave passes 0V.

- See the figure at right -

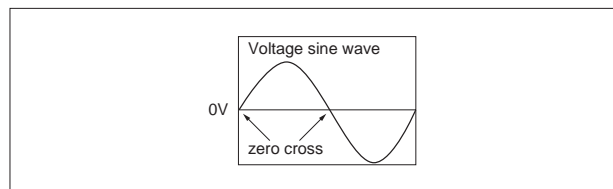

FAILURE TO FOLLOW THE ABOVE CAUTIONS MAY RESULT, WORST CASE, IN A SHORT CIRCUIT AND CAUSE FUMING OR PARTIAL DISPERSION WHEN THE PRODUCT IS USED.

For General Purpose GRM/GRJ Series

Only for Applications

AC250V Type GA2 Series

Safety Standard Certified GA3 Series

Product Information △Caution

For General Purpose
GRM/GRJ Series

Only for Applications

AC250V Type
GA2 Series

Safety Standard
Certified GA3 Series

Product Information
⚠Caution

⚠Caution

■ Caution (Soldering and Mounting)

1. Vibration and Impact

Do not expose a capacitor to excessive shock or vibration during use.

2. Circuit Board Material

It is possible for the chip to crack by the expansion and shrinkage of a metal board.
Please contact us if you want to use our ceramic capacitors on a metal board such as Aluminum.

3. Land Layout for Cropping PC Board

Choose a mounting position that minimizes the stress imposed on the chip during flexing or bending of the board.

[Component Direction]

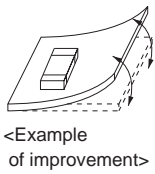
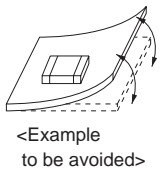

Locate chip horizontal to the direction in which stress acts.

[Chip Mounting Close to Board Separation Point]

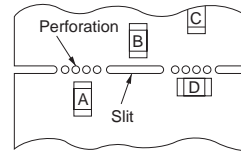

Chip arrangement
Worst A>C>B~D Best

Continued on the following page.

Caution

Continued from the preceding page.

4. Reflow Soldering

- When components are exposed to sudden heat, their mechanical strength can be decreased due to the extreme temperature changes which can cause flexing and result in internal mechanical damage, which will cause the parts to fail. In order to prevent mechanical damage, preheating is required for both the components and the PCB board. Preheating conditions are shown in Table 1. It is required to keep the temperature differential between the soldering and the components surface (ΔT) as small as possible.
- Solderability of Tin plating termination chips might be deteriorated when low temperature soldering profile where peak solder temperature is below the Tin melting point is used. Please confirm the solderability of Tin plating termination chips before use.
- When components are immersed in solvent after mounting, be sure to maintain the temperature difference (ΔT) between the component and solvent within the range shown in the Table 1.

Table 1

| Part Number | Temperature Differential |
|-------------------|-----------------------------------|
| G□□18/21/31 | $\Delta T \leq 190^\circ\text{C}$ |
| G□□32/42/43/52/55 | $\Delta T \leq 130^\circ\text{C}$ |

Recommended Conditions

| | Pb-Sn Solder | | Lead Free Solder |
|------------------|-----------------|--------------|-----------------------|
| | Infrared Reflow | Vapor Reflow | |
| Peak Temperature | 230-250°C | 230-240°C | 240-260°C |
| Atmosphere | Air | Air | Air or N ₂ |

Pb-Sn Solder: Sn-37Pb
 Lead Free Solder: Sn-3.0Ag-0.5Cu

Optimum Solder Amount for Reflow Soldering

- Overly thick application of solder paste results in excessive solder fillet height. This makes the chip more susceptible to mechanical and thermal stress on the board and may cause cracked chips.
- Too little solder paste results in a lack of adhesive strength on the outer electrode, which may result in chips breaking loose from the PCB.
- Make sure the solder has been applied smoothly to the end surface to a height of 0.2mm min.

Inverting the PCB

Make sure not to impose an abnormal mechanical shock on the PCB.

[Standard Conditions for Reflow Soldering]

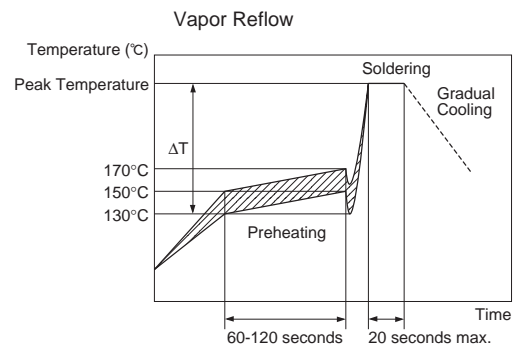
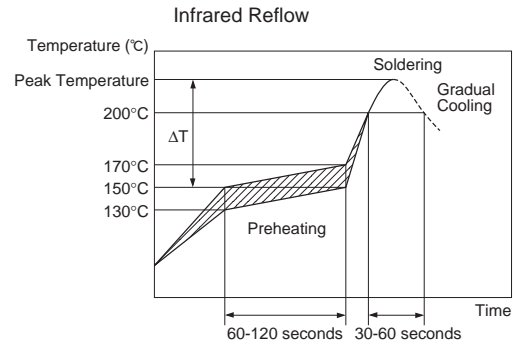

[Allowable Soldering Temperature and Time]

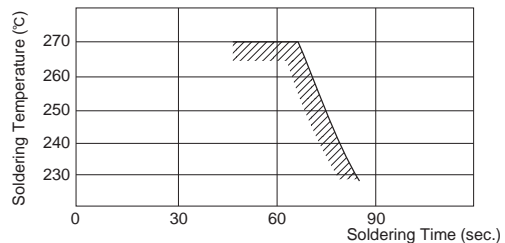

In the case of repeated soldering, the accumulated soldering time must be within the range shown above.

[Optimum Solder Amount for Reflow Soldering]

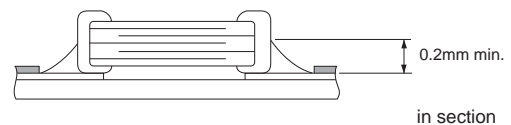

For General Purpose GRM/GRJ Series
 Only for Applications
 AC250V Type GA2 Series
 Safety Standard Certified GA3 Series
 Product Information Caution

For General Purpose GRM/GRJ Series

Only for Applications

AC250V Type GA2 Series

Safety Standard Certified GA3 Series

Product Information △Caution

△Caution

Continued from the preceding page.

5. Flow Soldering

- When components are exposed to sudden heat, their mechanical strength can be decreased due to the extreme temperature changes which can cause flexing and result in internal mechanical damage, which will cause the parts to fail. Additionally, an excessively long soldering time or high soldering temperature results in leaching by the outer electrodes, causing poor adhesion or a reduction in capacitance value due to loss of contact between electrodes and end termination.
- In order to prevent mechanical damage, preheating is required for both the components and the PCB board. Preheating conditions are shown in Table 2. It is required to keep temperature differential between the soldering and the components surface (ΔT) as small as possible.
- When components are immersed in solvent after mounting, be sure to maintain the temperature difference between the component and solvent within the range shown in Table 2.
Do not apply flow soldering to chips not listed in Table 2.

Table 2

| Part Number | Temperature Differential |
|-------------|-----------------------------------|
| G□□18/21/31 | $\Delta T \leq 150^\circ\text{C}$ |

Recommended Conditions

| | Pb-Sn Solder | Lead Free Solder |
|------------------|--------------|------------------|
| Peak Temperature | 240-250°C | 250-260°C |
| Atmosphere | Air | N ₂ |

Pb-Sn Solder: Sn-37Pb
Lead Free Solder: Sn-3.0Ag-0.5Cu

- Optimum Solder Amount for Flow Soldering
The top of the solder fillet should be lower than the thickness of components. If the solder amount is excessively large, the risk of cracking is higher during board bending or under any other stressful conditions.

[Standard Conditions for Flow Soldering]

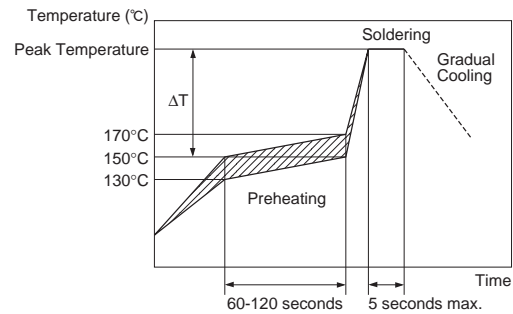

[Allowable Soldering Temperature and Time]

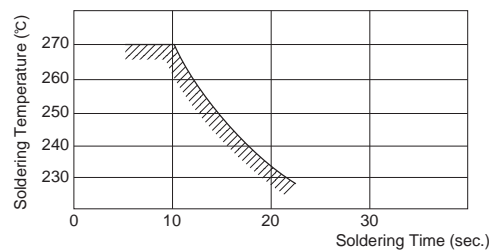

In the case of repeated soldering, the accumulated soldering time must be within the range shown above.

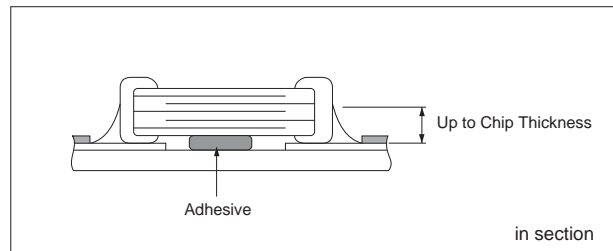

Continued on the following page. ↗

Caution

Continued from the preceding page.

6. Correction with a Soldering Iron

- When sudden heat is applied to the components by use of a soldering iron, the mechanical strength of the components will decrease because the extreme temperature change causes deformations inside the components.

In order to prevent mechanical damage to the components, preheating is required for both the components and the PCB board.

Preheating conditions, (The "Temperature of the Soldering Iron Tip", "Preheating Temperature," "Temperature Differential" between iron tip and the

components and the PCB), should be within the conditions of table 3.

It is required to keep the temperature differential between the soldering iron and the component's surface (ΔT) as small as possible.

After soldering, do not allow the component/PCB to cool down rapidly.

The operating time for the re-working should be as short as possible. When re-working time is too long, it may cause solder leaching, in turn causing a reduction of the adhesive strength of the terminations.

Table 3

| Part Number | Temperature of Soldering Iron tip | Preheating Temperature | Temperature Differential (ΔT) | Atmosphere |
|-------------------|-----------------------------------|------------------------|---|------------|
| G□□18/21/31 | 350°C max. | 150°C min. | $\Delta T \leq 190^\circ\text{C}$ | air |
| G□□32/42/43/52/55 | 280°C max. | 150°C min. | $\Delta T \leq 130^\circ\text{C}$ | air |

*Applicable for both Pb-Sn and Lead Free Solder.
 Pb-Sn Solder: Sn-37Pb
 Lead Free Solder: Sn-3.0Ag-0.5Cu

- Optimum Solder Amount when re-working Using a Soldering Iron

For sizes smaller than G□□18, the top of the solder fillet should be lower than 2/3 of the thickness of the component or 0.5mm whichever is smaller.

For sizes larger than G□□21, the top of the solder fillet should be lower than 2/3 of the thickness of the component.

If the solder amount is excessive, the risk of cracking is higher during board bending or under any other stressful conditions.

A Soldering iron $\phi 3\text{mm}$ or smaller should be used.

It is also necessary to keep the soldering iron from touching the components during the re-work.

Solder wire with $\phi 0.5\text{mm}$ or smaller is required for soldering.

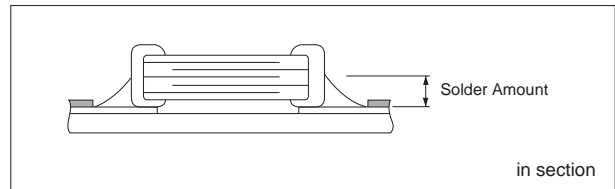

7. Washing

Excessive output of ultrasonic oscillation during cleaning causes PCBs to resonate, resulting in cracked chips or broken solder. Take note not to vibrate PCBs.

FAILURE TO FOLLOW THE ABOVE CAUTIONS MAY RESULT, WORST CASE, IN A SHORT CIRCUIT AND FUMING WHEN THE PRODUCT IS USED.

For General Purpose GRM/GRJ Series

Only for Applications

AC250V Type GA2 Series

Safety Standard Certified GA3 Series

Product Information △Caution

Notice

■ Notice (Soldering and Mounting)

1. Construction of Board Pattern

After installing chips, if solder is excessively applied to the circuit board, mechanical stress will cause destruction resistance characteristics to lower. To prevent this, be extremely careful in determining shape and dimension before designing the circuit board diagram.

Construction and Dimensions of Pattern (Example)

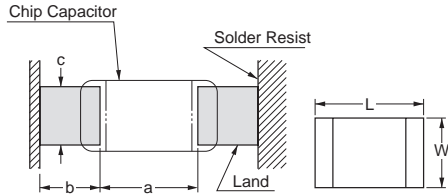

Flow Soldering

| L×W | a | b | c |
|----------|---------|---------|---------|
| 1.6×0.8 | 0.6-1.0 | 0.8-0.9 | 0.6-0.8 |
| 2.0×1.25 | 1.0-1.2 | 0.9-1.0 | 0.8-1.1 |
| 3.2×1.6 | 2.2-2.6 | 1.0-1.1 | 1.0-1.4 |

Flow soldering : 3.2×1.6 or less available.

Reflow Soldering

| L×W | a | b | c |
|----------|---------|---------|---------|
| 1.6×0.8 | 0.6-0.8 | 0.6-0.7 | 0.6-0.8 |
| 2.0×1.25 | 1.0-1.2 | 0.6-0.7 | 0.8-1.1 |
| 3.2×1.6 | 2.2-2.4 | 0.8-0.9 | 1.0-1.4 |
| 3.2×2.5 | 2.0-2.4 | 1.0-1.2 | 1.8-2.3 |
| 4.5×2.0 | 2.8-3.4 | 1.2-1.4 | 1.4-1.8 |
| 4.5×3.2 | 2.8-3.4 | 1.2-1.4 | 2.3-3.0 |
| 5.7×2.8 | 4.0-4.6 | 1.4-1.6 | 2.1-2.6 |
| 5.7×5.0 | 4.0-4.6 | 1.4-1.6 | 3.5-4.8 |

(in mm)

Dimensions of Slit (Example)

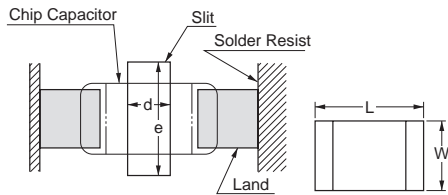

| L×W | d | e |
|----------|---------|---------|
| 1.6×0.8 | - | - |
| 2.0×1.25 | - | - |
| 3.2×1.6 | 1.0-2.0 | 3.2-3.7 |
| 3.2×2.5 | 1.0-2.0 | 4.1-4.6 |
| 4.5×2.0 | 1.0-2.8 | 3.6-4.1 |
| 4.5×3.2 | 1.0-2.8 | 4.8-5.3 |
| 5.7×2.8 | 1.0-4.0 | 4.4-4.9 |
| 5.7×5.0 | 1.0-4.0 | 6.6-7.1 |

(in mm)

Preparing the slit helps flux cleaning and resin coating on the back of the capacitor. However, the length of the slit design should be as short as possible to prevent mechanical damage in the capacitor. A longer slit design might receive more severe mechanical stress from the PCB. Recommended slit design is shown in the Table.

Continued on the following page. ↗

Notice

Continued from the preceding page.

Land Layout to Prevent Excessive Solder

| | Mounting Close to a Chassis | Mounting with Leaded Components | Mounting Leaded Components Later |
|---|-----------------------------|---------------------------------|----------------------------------|
| Examples to Be Avoided | | | |
| Examples of Improvements by the Land Division | | | |

2. Mounting of Chips

- Thickness of adhesives applied
Keep thickness of adhesives applied (50-105µm or more) to reinforce the adhesive contact considering the thickness of the termination or capacitor (20-70µm) and the land pattern (30-35µm).
- Mechanical shock of the chip placer
When the positioning claws and pick-up nozzle are worn, the load is applied to the chip while positioning is concentrated in one position, thus causing cracks, breakage, faulty positioning accuracy, etc. Careful checking and maintenance are necessary to prevent unexpected trouble.
An excessively low bottom dead point of the suction nozzle imposes great force on the chip during mounting, causing cracked chips. Please set the suction nozzle's bottom dead point on the upper surface of the board.

3. Soldering

- (1) Limit of losing effective area of the terminations and conditions needed for soldering.

Depending on the conditions of the soldering temperature and/or immersion (melting time), effective areas may be lost in some parts of the terminations.

To prevent this, be careful in soldering so that any possible loss of the effective area on the terminations will securely remain at a maximum of 25% on all edge length A-B-C-D-A of part with A, B, C, D, shown in the Figure below.

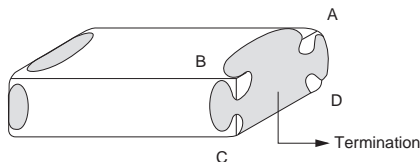

- (2) Flux Application

- An excessive amount of flux generates a large quantity of flux gas, causing deteriorated solderability. So apply flux thinly and evenly throughout. (A foaming system is generally used for flow soldering.)
- Flux containing too high a percentage of halide may cause corrosion of the outer electrodes without sufficient cleaning. Use flux with a halide content of 0.2% max.
- Do not use strong acidic flux.
- Do not use water-soluble flux.*
(*Water-soluble flux can be defined as non rosin type flux including wash-type flux and non-wash-type flux.)

- (3) Solder

The use of Sn-Zn based solder will deteriorate the reliability of the MLCC. Please contact our sales representative or product engineers on the use of Sn-Zn based solder in advance.

Continued on the following page.

For General Purpose GRM/GRJ Series

Only for Applications

AC250V Type GA2 Series

Safety Standard Certified GA3 Series

Product Information Notice

Notice

☒ Continued from the preceding page.

4. Cleaning

Please confirm there is no problem in the reliability of the product beforehand when cleaning it with the intended equipment.

The residue after cleaning it might cause a decrease in the surface resistance of the chip and the corrosion of the electrode part, etc. As a result it might cause reliability to deteriorate. Please confirm beforehand that there is no problem with the intended equipment in ultrasonic cleansing.

5. Resin Coating

Please use it after confirming there is no influence on the product with the intended equipment before the resin coating and molding.

A cracked chip might be caused at the cooling/heating cycle by the amount of resin spreading and/or bias thickness.

The resin for coating and molding must be selected as the stress is small when stiffening and the hygroscopic is low as possible.

■ Rating

1. Capacitance change of capacitor

(1) In the case of X7R char.

Capacitors have an aging characteristic, whereby the capacitor continually decreases its capacitance slightly if the capacitor is left on for a long time. Moreover, capacitance might change greatly depending on the surrounding temperature or an applied voltage. Therefore, it is not likely to be suitable for use in a time constant circuit.

Please contact us if you need detailed information.

(2) In the case of any char. except X7R

Capacitance might change a little depending on the surrounding temperature or an applied voltage.

Please contact us if you intend to use this product in a strict time constant circuit.

2. Performance check by equipment

Before using a capacitor, check that there is no problem in the equipment's performance and the specifications.

Generally speaking, CLASS 2 (X7R char.) ceramic capacitors have voltage dependence characteristics and temperature dependence characteristics in capacitance. Therefore, the capacitance value may change depending on the operating condition in the equipment.

Accordingly, be sure to confirm the apparatus performance of receiving influence in a capacitance value change of a capacitor, such as leakage current and noise suppression characteristics.

Moreover, check the surge-proof ability of a capacitor in the equipment, if needed, because the surge voltage may exceed the specific value by the inductance of the circuit.

ISO 9001 Certifications

■ Qualified Standards

The products listed here have been produced by ISO 9001 certified factory.

| Plant |
|--|
| Fukui Murata Mfg. Co., Ltd. |
| Izumo Murata Mfg. Co., Ltd. |
| Okayama Murata Mfg. Co., Ltd. |
| Murata Electronics Singapore (Pte.) Ltd. |
| Beijing Murata Electronics Co., Ltd. |
| Wuxi Murata Electronics Co., Ltd. |

Design assistant tool SimSurfing

SimSurfing



MLCC is now available !

Design assistant tool "SimSurfing" has been updated and you can now find and view any kind of characteristics of MLCCs.

Available function for MLCCs.

- ① Products search
- ② View frequency characteristics (S parameters, Z, R, X, Q, DF, L, C)
- ③ DC voltage bias characteristics (Absolute capacitance/change rate)
- ④ Temperature characteristics (Absolute capacitance/change rate)
- ⑤ AC voltage bias characteristics (Absolute capacitance/change rate)
- ⑥ Download SPICE netlist/ S parameter

① Select the Products

- (1) By part number
- (2) By performance

② View characteristics

Clicking buttons in this area with partnumber selected, you can view any electrical characteristics chart.

③ Data download

You can download SPICE netlist and S parameter files (S2P)

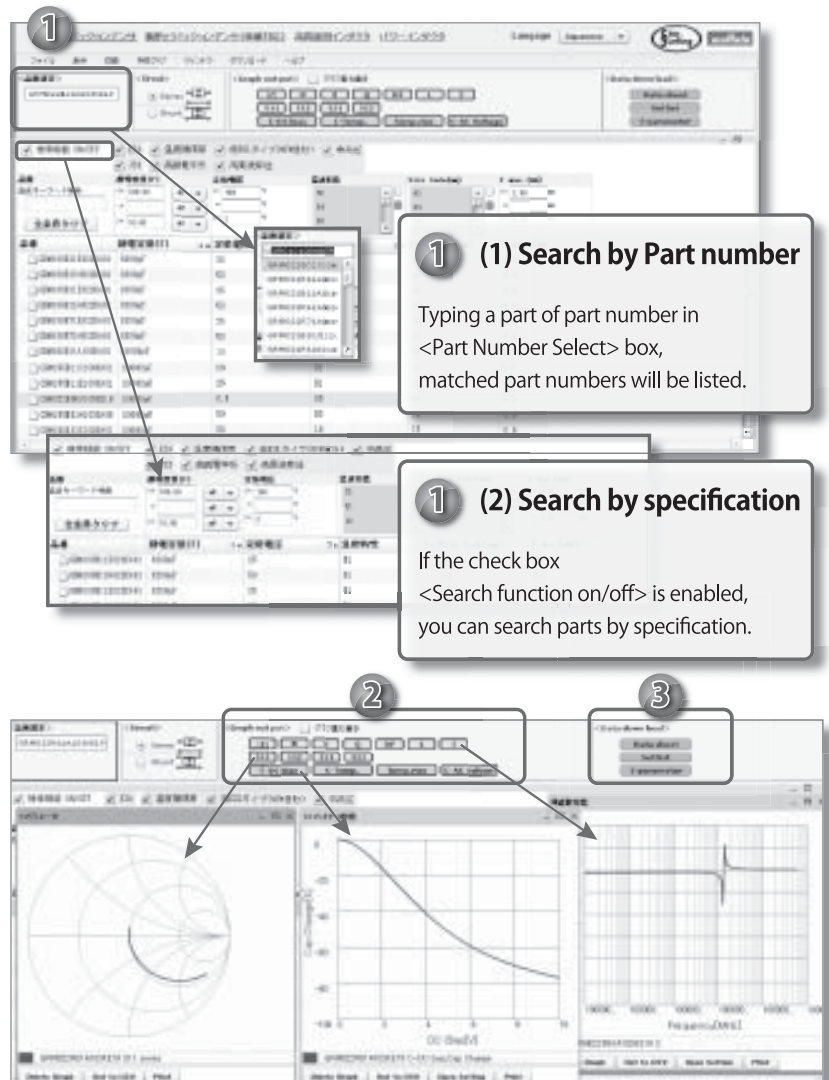

These images are captured at August/2010. Be sure that this software will be updated frequently.

<http://ds.murata.com/software/simsurfing/en-us/mlcc/>

EMICON-FUN!

Please check Murata's newsletter!
 You can learn about electric parts with fun.
http://www.murata.com/products/emicon_fun/

EMICON COLUMN introduce hand-made columns with know-how of capacitors, inductors and EMI suppression filters.
 m's CAFÉ is a relaxing easy essay. Please make yourself at home with EMICON-FUN!

You can register from Murata Manufacturing Web site page TOP.
<http://www.murata.com/>



← This banner is the entrance of register form

EMICON-FUN!
 Expertly written articles explain the basics of capacitors, inductors and EMI suppression filters.

Capacitor Room
 Introduce quick know-how, and inside story of capacitors

EMICON COLUMN

- Capacitor Room
- Inductor Room
- Noise suppression filter Room
- For the EARTH
- SPECIAL CONTENTS

m's CAFÉ

MURATA BOY & MURATA GIRL

Murata Newsletter
 EMICON-FUN! also available.
 Click here to register as reader.

News changes to your registration or unsubscribe from e-Magazine.
 The purpose of obtaining your personal information.

Search by keyword
 design assistance tool
 power inductors
 rated current
 SimSurfing

Search by updated date
 Oct 2010

Recent articles
 Oct 10, 2010 **Inductor Room**
 Why do power inductors have two types of rated currents?

EMICON-FUN!
 The index of October 28 issue

- EMI suppression filter Room
- "Say Hello to MURATA BOY"
- Products news
- Introduction of "SimSurfing"
- Questionnaire & Gift

Expertly written articles explain the basics of capacitors, inductors and EMI suppression filters.

EMI suppression filter Room
 What is an EMI filter?

This column aims to provide a basic explanation about noise countermeasures, from "What is EMI?" to the functions and uses of various noise countermeasure parts. This first column starts with the question, "What is an EMI filter?"
http://newsletter.murata.co.jp/c_p702c2aRO88

"Say Hello to MURATA BOY"

Check it out! http://newsletter.murata.co.jp/c_p712c2aRO88

You have a chance to get Murata's original goods each month by answering to a short questionnaire!
 *The kind of presents and lottery frequency may be changed without notice.

△Note:

1. Export Control

<For customers outside Japan>

No Murata products should be used or sold, through any channels, for use in the design, development, production, utilization, maintenance or operation of, or otherwise contribution to (1) any weapons (Weapons of Mass Destruction [nuclear, chemical or biological weapons or missiles] or conventional weapons) or (2) goods or systems specially designed or intended for military end-use or utilization by military end-users.

<For customers in Japan>

For products which are controlled items subject to the "Foreign Exchange and Foreign Trade Law" of Japan, the export license specified by the law is required for export.

2. Please contact our sales representatives or product engineers before using the products in this catalog for the applications listed below, which require especially high reliability for the prevention of defects which might directly damage a third party's life, body or property, or when one of our products is intended for use in applications other than those specified in this catalog.

- | | |
|-----------------------------|--|
| ① Aircraft equipment | ② Aerospace equipment |
| ③ Undersea equipment | ④ Power plant equipment |
| ⑤ Medical equipment | ⑥ Transportation equipment (vehicles, trains, ships, etc.) |
| ⑦ Traffic signal equipment | ⑧ Disaster prevention / crime prevention equipment |
| ⑨ Data-processing equipment | ⑩ Application of similar complexity and/or reliability requirements to the applications listed above |

3. Product specifications in this catalog are as of September 2010. They are subject to change or our products in it may be discontinued without advance notice. Please check with our sales representatives or product engineers before ordering. If there are any questions, please contact our sales representatives or product engineers.

4. Please read rating and △CAUTION (for storage, operating, rating, soldering, mounting and handling) in this catalog to prevent smoking and/or burning, etc.

5. This catalog has only typical specifications because there is no space for detailed specifications. Therefore, please approve our product specifications or transact the approval sheet for product specifications before ordering.

6. Please note that unless otherwise specified, we shall assume no responsibility whatsoever for any conflict or dispute that may occur in connection with the effect of our and/or a third party's intellectual property rights and other related rights in consideration of your use of our products and/or information described or contained in our catalogs. In this connection, no representation shall be made to the effect that any third parties are authorized to use the rights mentioned above under licenses without our consent.

7. No ozone depleting substances (ODS) under the Montreal Protocol are used in our manufacturing process.



Murata Manufacturing Co., Ltd.

<http://www.murata.com/>

Head Office

1-10-1, Higashi Kotari, Nagaokakyo-shi, Kyoto 617-8555, Japan
Phone: 81-75-951-9111

International Division

3-29-12, Shibuya, Shibuya-ku, Tokyo 150-0002, Japan
Phone: 81-3-5469-6123 Fax: 81-3-5469-6155 E-mail: intl@murata.co.jp