

阅读申明

- 1.本站收集的数据手册和产品资料都来自互联网，版权归原作者所有。如读者和版权方有任何异议请及时告之，我们将妥善解决。
- 2.本站提供的中文数据手册是英文数据手册的中文翻译，其目的是协助用户阅读，该译文无法自动跟随原稿更新，同时也可能存在翻译上的不当。建议读者以英文原稿为参考以便获得更精准的信息。
- 3.本站提供的产品资料，来自厂商的技术支持或者使用者的心得体会等，其内容可能存在描述上的差异，建议读者做出适当判断。
- 4.如需与我们联系，请发邮件到marketing@iczoom.com，主题请标有“数据手册”字样。

Read Statement

1. The datasheets and other product information on the site are all from network reference or other public materials, and the copyright belongs to the original author and original published source. If readers and copyright owners have any objections, please contact us and we will deal with it in a timely manner.
2. The Chinese datasheets provided on the website is a Chinese translation of the English datasheets. Its purpose is for reader's learning exchange only and do not involve commercial purposes. The translation cannot be automatically updated with the original manuscript, and there may also be improper translations. Readers are advised to use the English manuscript as a reference for more accurate information.
3. All product information provided on the website refer to solutions from manufacturers' technical support or users the contents may have differences in description, and readers are advised to take the original article as the standard.
4. If you have any questions, please contact us at marketing@iczoom.com and mark the subject with "Datasheets" .

DATA SHEET

Mono-axial™ series
**Leaded ceramic multilayer
capacitors**

Product specification
Supersedes data of 24th August 2000
File under BCcomponents, BC06

2002 Oct 24

Leaded ceramic multilayer capacitors

Mono-axial™ series

FEATURES

- High capacitance per unit volume
- Low cost.

APPLICATIONS

These conformally coated axial leaded capacitors are designed for commercial and industrial applications in four dielectrics, NP0 (ultra-stable), X7R (stable) and Z5U, Y5V (general purpose). Applications include timing, coupling/decoupling, signal comparison and biasing. Mono-axial™ capacitors are suitable for automatic insertion equipment.

DESCRIPTION

The basic capacitor construction consists of ceramic dielectric materials processed into a tape with a typical thickness range from 0.025 to 0.076 mm. Metal electrode patterns are applied using a thick film screening process. Multiple layers are stacked and laminated in such a manner that electrodes are alternately exposed when the pattern is cut into individual chip capacitors. The capacitors are fired through a high temperature profile to mature the ceramic and metal into a homogeneous unit.

Metal end terminations are applied and fired to provide electrical connection between the individual layers. Tinned leads are attached using a solder. Encapsulation consists of a moisture resistant gold colour conformal epoxy coating that meets the flame requirements of "UL94V-0".

QUICK REFERENCE DATA

DESCRIPTION	VALUE							
	2252 205	2252 206	2252 225	2252 226	2252 245	2252 246	2252 262	2252 265
Capacitance range	10 to 5600 pF		220 pF to 0.22 µF		1000 pF to 1.0 µF		0.01 to 1.0 µF	
Rated DC voltage	50 V	100 V	50 V ⁽¹⁾	100 V ⁽¹⁾	50 V ⁽¹⁾	100 V ⁽¹⁾	25 V	50 V
Tolerance on capacitance	±5%		±10%		±20%		+80%/−20%	
Temperature coefficient	NP0		X7R		Z5U		Y5V	

Note

1. 7th digit of the catalogue number for U_{R(DC)} 25 V is: 2.

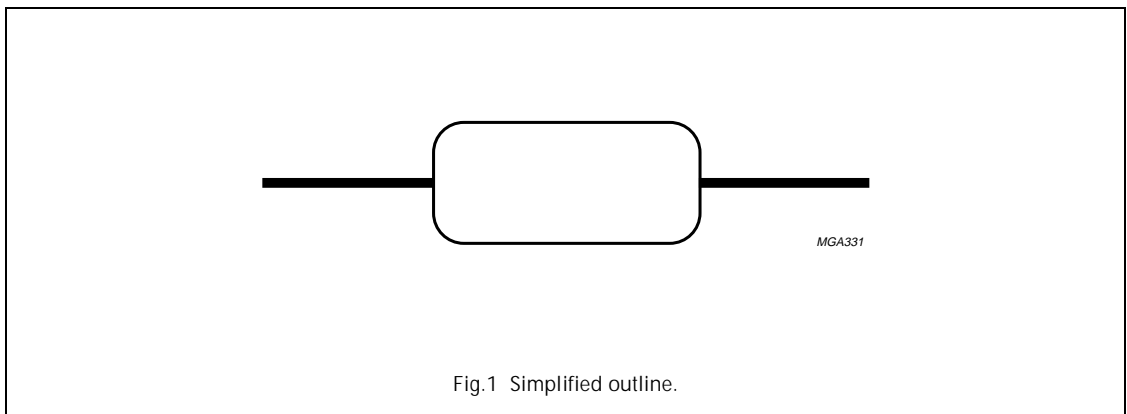

Leaded ceramic multilayer capacitors

Mono-axial™ series

MECHANICAL DATA

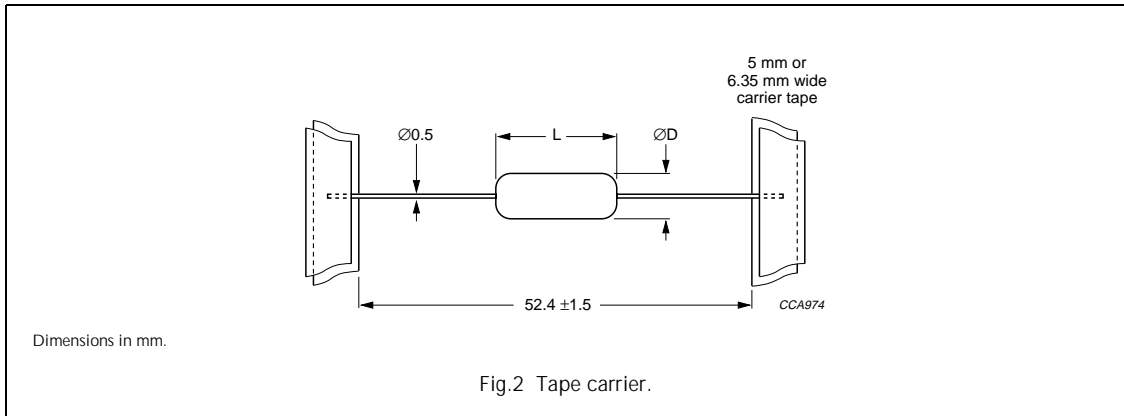

Marking (see Fig.3)

Date code (DDD):

Three-digit code; first digit denotes year, last two denote week of manufacture.

941 = 1999, wk 41

Capacitance value (CCC):

10 pF to 99 pF; actual value in pF (2 digits only)

100 pF and above; coded capacitance value (same as used in P/N).

Capacitance tolerance (T):

Standard EIA tolerance (same as used in P/N).

Material code (M):

A = C0G

C = X7R

E = Z5U

Y = Y5V.

Voltage code (V):

1 = 100 V

3 = 25 V

5 = 50 V.

Physical dimensions

Table 1 Capacitor dimensions and mass

SIZE	L _{max} ⁽¹⁾ (mm)	ØD _{max} ⁽¹⁾ (mm)	MASS (g)
15	3.8 (0.150)	2.5 (0.100)	≈0.14
20	5.0 (0.200)	3.0 (0.120)	≈0.14

Note

- Dimensions between parentheses are in inches.

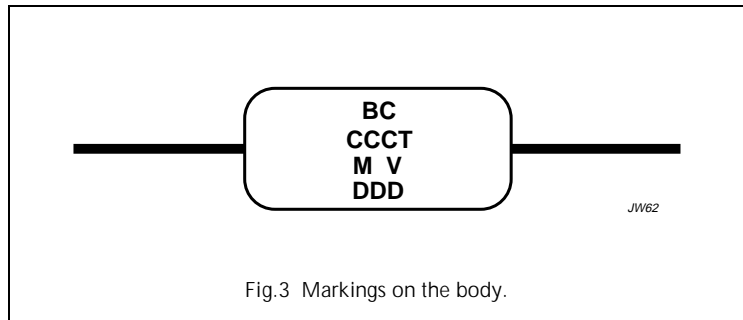

Leaded ceramic multilayer capacitors

Mono-axial™ series

CAPACITANCE RANGE CHARTS

NPO Dielectric

CAP.	SIZE CODE 15		SIZE CODE 20	
	50 V	100 V	50 V	100 V
	10 pF			
12				
15				
18				
22				
27				
33				
39				
47				
56				
68				
82				
100				
120				
150				
180				
220				
270				
330				
390				
470				
560				
680				
820				
1000				
1200				
1500				
1800				
2200				
2700				
3300				
3900				
4700				
5600				
6800				
8200				
0.01 μF				

X7R Dielectric

CAP.	SIZE CODE 15			SIZE CODE 20		
	25 V	50 V	100 V	25 V	50 V	100 V
	100-220 pF					
270						
330						
390						
470						
560						
680						
820						
1000						
1200						
1500						
1800						
2200						
2700						
3300						
3900						
4700						
5600						
6800						
8200						
0.01 μF						
0.012						
0.015						
0.018						
0.022						
0.027						
0.033						
0.039						
0.047						
0.056						
0.068						
0.082						
0.10						
0.12						
0.15						
0.22						

Leaded ceramic multilayer capacitors

Mono-axial™ series

Z5U Dielectric

CAP.	SIZE CODE 15			SIZE CODE 20	
	25 V	50 V	100 V	50 V	100 V
1000 pF					
1500					
2200					
3300					
4700					
6800					
0.01 μ F					
0.015					
0.022					
0.033					
0.047					
0.068					
0.10					
0.15					
0.22					
0.33					
0.47					
0.68					
1.0					

Y5V Dielectric

CAP.	SIZE CODE 15		SIZE CODE 20	
	25 V	50 V	25 V	50 V
0.01 μ F				
0.015				
0.022				
0.033				
0.047				
0.068				
0.10				
0.15				
0.22				
0.33				
0.47				
0.68				
1.0				

Leaded ceramic multilayer capacitors

Mono-axial™ series

ORDERING INFORMATION

Components may be ordered by using either a simple 15-digit clear text code, or BCcomponents 12NC.

Clear text code

EXAMPLE: A103K15X7RF5TAA

PRODUCT TYPE	CAPACITANCE (pF)	TOLERANCE	SIZE CODE (mm)	DIELECTRIC	RATED VOLTAGE	LEAD DIA. (mm)	PACKAGING
A = mono-axial	two significant digits followed by the number of zeros: 101 = 100 103 = 10000	J = ±5% K = ±10% M = ±20% Z = +80%/-20%	15 = 3.8 (.150") max. 20 = 5.0 (.200") max.	COG (NP0) X7R Z5U Y5V	E = 25 V F = 50 V H = 100 V	5 = 0.5 (0.020") max.	TAA = tape & reel UAA = ammopack

Ordering code 12NC

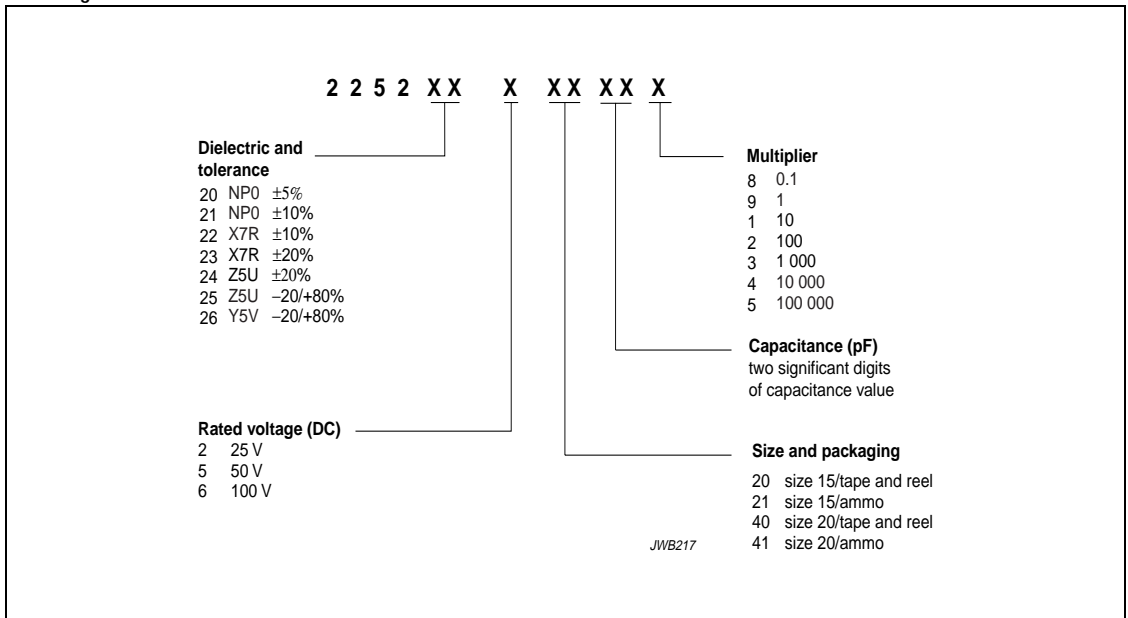

Leaded ceramic multilayer capacitors

Mono-axial™ series

Table 2 Capacitance, rated voltage, mechanical dimensions and ordering information

C	U _{R(DC)} (V)	SIZE CODE	CLEAR TEXT CODE	CATALOGUE NUMBER
NP0 (C0G) ±5% tolerance				
10 pF	50	15	A100J15C0GF5UAA	2252 205 21109
	100	15	A100J15C0GH5UAA	2252 206 21109
12 pF	50	15	A120J15C0GF5UAA	2252 205 21129
15 pF	50	15	A150J15C0GF5UAA	2252 205 21159
18 pF	50	15	A180J15C0GF5UAA	2252 205 21189
22 pF	50	15	A220J15C0GF5UAA	2252 205 21229
	100	15	A220J15C0GH5UAA	2252 206 21229
27 pF	50	15	A270J15C0GF5UAA	2252 205 21279
33 pF	50	15	A330J15C0GF5UAA	2252 205 21339
39 pF	50	15	A390J15C0GF5UAA	2252 205 21399
47 pF	50	15	A470J15C0GF5UAA	2252 205 21479
	100	15	A470J15C0GH5UAA	2252 206 21479
56 pF	50	15	A560J15C0GF5UAA	2252 205 21569
68 pF	50	15	A680J15C0GF5UAA	2252 205 21689
82 pF	50	15	A820J15C0GF5UAA	2252 205 21829
100 pF	50	15	A101J15C0GF5UAA	2252 205 21101
	100	15	A101J15C0GH5UAA	2252 206 21101
150 pF	50	15	A151J15C0GF5UAA	2252 205 21151
220 pF	50	15	A221J15C0GF5UAA	2252 205 21221
	100	15	A221J15C0GH5UAA	2252 206 21221
330 pF	50	15	A331J15C0GF5UAA	2252 205 21331
470 pF	50	15	A471J15C0GF5UAA	2252 205 21471
	100	15	A471J15C0GH5UAA	2252 206 21471
680 pF	50	15	A681J15C0GF5UAA	2252 205 21681
1000 pF	50	15	A102J15C0GF5UAA	2252 205 21102
	100	20	A102J20C0GH5UAA	2252 206 41102
1500 pF	50	15	A152J15C0GF5UAA	2252 205 21152
2200 pF	50	15	A222J15C0GF5UAA	2252 205 21222
3300 pF	50	20	A332J20C0GF5UAA	2252 205 41332
4700 pF	50	20	A472J20C0GF5UAA	2252 205 41472
5600 pF	50	20	A562J20C0GF5UAA	2252 205 41562

Leaded ceramic multilayer capacitors

Mono-axial™ series

C	U _{R(DC)} (V)	SIZE CODE	CLEAR TEXT CODE	CATALOGUE NUMBER
X7R ±10% tolerance				
100 pF	50	15	A101K15X7RF5UAA	2252 225 21101
	100	15	A101K15X7RH5UAA	2252 226 21101
150 pF	50	15	A151K15X7RF5UAA	2252 225 21151
	100	15	A151K15X7RH5UAA	2252 226 21151
220 pF	50	15	A221K15X7RF5UAA	2252 225 21221
	100	15	A221K15X7RH5UAA	2252 226 21221
330 pF	50	15	A331K15X7RF5UAA	2252 225 21331
470 pF	50	15	A471K15X7RF5UAA	2252 225 21471
	100	15	A471K15X7RH5UAA	2252 226 21471
680 pF	50	15	A681K15X7RF5UAA	2252 225 21681
1 000 pF	50	15	A102K15X7RF5UAA	2252 225 21102
	100	15	A102K15X7RH5UAA	2252 226 21102
1 500 pF	50	15	A152K15X7RF5UAA	2252 225 21152
2 200 pF	50	15	A222K15X7RF5UAA	2252 225 21222
	100	15	A222K15X7RH5UAA	2252 226 21222
3 300 pF	50	15	A332K15X7RF5UAA	2252 225 21332
4 700 pF	50	15	A472K15X7RF5UAA	2252 225 21472
	100	15	A472K15X7RH5UAA	2252 226 21472
6 800 pF	50	15	A682K15X7RF5UAA	2252 225 21682
0.01 µF	50	15	A103K15X7RF5UAA	2252 225 21103
	100	15	A103K15X7RH5UAA	2252 226 21103
0.015 µF	50	15	A153K15X7RF5UAA	2252 225 21153
0.022 µF	50	15	A223K15X7RF5UAA	2252 225 21223
	100	15	A223K15X7RH5UAA	2252 226 21223
0.033 µF	50	15	A333K15X7RF5UAA	2252 225 21333
0.047 µF	50	15	A473K15X7RF5UAA	2252 225 21473
	100	20	A473K20X7RH5UAA	2252 226 41473
0.068 µF	50	15	A683K15X7RF5UAA	2252 225 21683
0.1 µF	25	15	A104K15X7RE5UAA	2252 222 21104
	50	15	A104K15X7RF5UAA	2252 225 21104
	100	20	A104K20X7RH5UAA	2252 226 41104
0.15 µF	25	20	A154K20X7RE5UAA	2252 222 41154
0.22 µF	25	20	A224K20X7RE5UAA	2252 222 41224

Leaded ceramic multilayer capacitors

Mono-axial™ series

C	U _{R(DC)} (V)	SIZE CODE	CLEAR TEXT CODE	CATALOGUE NUMBER
Z5U ±20% tolerance				
1 000 pF	50	15	A102M15Z5UF5UAA	2252 245 21102
	100	15	A102M15Z5UH5UAA	2252 246 21102
2 200 pF	50	15	A222M15Z5UF5UAA	2252 245 21222
4 700 pF	50	15	A472M15Z5UF5UAA	2252 245 21472
0.01 µF	50	15	A103M15Z5UF5UAA	2252 245 21103
	100	15	A103M15Z5UH5UAA	2252 246 21103
0.022 µF	50	15	A223M15Z5UF5UAA	2252 245 21223
0.047 µF	50	15	A473M15Z5UF5UAA	2252 245 21473
0.1 µF	25	15	A104M15Z5UE5UAA	2252 242 21104
	50	15	A104M15Z5UF5UAA	2252 245 21104
	100	20	A104M20Z5UH5UAA	2252 246 41104
0.22 µF	50	15	A224M15Z5UF5UAA	2252 245 21224
0.47 µF	50	20	A474M20Z5UF5UAA	2252 245 41474
0.68 µF	50	20	A684M20Z5UF5UAA	2252 245 41684
1.00 µF	50	20	A105M20Z5UF5UAA	2252 245 41105
Y5V +80/-20% tolerance				
0.01 µF	50	15	A103Z15Y5VF5UAA	2252 265 21103
0.022 µF	50	15	A223Z15Y5VF5UAA	2252 265 21223
0.047 µF	50	15	A473Z15Y5VF5UAA	2252 265 21473
0.1 µF	25	15	A104Z15Y5VE5UAA	2252 262 21104
	50	15	A104Z15Y5VF5UAA	2252 265 21104
0.22 µF	25	20	A224Z20Y5VE5UAA	2252 262 41224
	50	20	A224Z20Y5VF5UAA	2252 265 41224
0.47 µF	25	20	A474Z20Y5VE5UAA	2252 262 41474
	50	20	A474Z20Y5VF5UAA	2252 265 41474
1.0 µF	25	20	A105Z20Y5VE5UAA	2252 262 41105

Leaded ceramic multilayer capacitors

Mono-axial™ series

ELECTRICAL CHARACTERISTICS

Table 3 Electrical data for NP0, X7R, Z5U and Y5V

The capacitors meet the essential requirements of "EIA 198".

Unless stated otherwise all electrical values apply at an ambient temperature of 25 ± 3 °C, at barometric pressures of 650 to 800 mm of mercury, and relative humidity not to exceed 75%.

DESCRIPTION	VALUE
Capacitors with temperature coefficient NP0	
Capacitance range: at 1 MHz, 1 V; where $C \leq 1000$ pF at 1 kHz, 1 V; where $C > 1000$ pF	10 to 1000 pF 1 200 to 5600 pF
Tolerance on the capacitance	$\pm 5\%$; $\pm 10\%$
Rated DC voltage	50 and 100 V
Dielectric strength	250% of rated voltage
Insulation resistance at rated voltage	100 000 M Ω or 1 000 M $\Omega \times \mu\text{F}$, whichever is less at rated voltage within 2 minutes of charging
Temperature coefficient of the capacitance	$0 \times 10^{-6}/\text{K}$
Tolerance on the temperature coefficient	$\pm 30 \times 10^{-6}/\text{K}$
Dissipation factor: at 1 MHz, 1 V; where $C \leq 30$ pF at 1 kHz, 1 V; where $C > 30$ pF	$< \frac{1}{(400 + 20 \times C)}$ $< 15 \times 10^{-4}$
Operating temperature range	-55 to +125 °C
Storage temperature range	25 \pm 15 °C
Capacitors with temperature coefficient X7R	
Capacitance range at 1 kHz, 1 V	220 pF to 0.22 μF
Tolerance on the capacitance	$\pm 10\%$; $\pm 20\%$
Maximum capacitance change with respect to capacitance value at 25 °C	$\pm 15\%$
Rated DC voltage	25 V, 50 V and 100 V
Dielectric strength	250% of rated voltage
Insulation resistance at rated voltage	100 000 M Ω or 1 000 M $\Omega \times \mu\text{F}$, whichever is less at rated voltage within 2 minutes of charging
Dissipation factor at 1 kHz, 1 V	$\leq 2.5\%$
Operating temperature range	-55 to +125 °C
Storage temperature range	25 \pm 15 °C
Ageing	typical 1% per time decade

Leaded ceramic multilayer capacitors

Mono-axial™ series

DESCRIPTION	VALUE
Capacitors with temperature coefficient Z5U	
Capacitance range at 1 kHz, 0.5 V	1000 pF to 1.00 μF
Tolerance on the capacitance	±20%; +80%/–20%
Maximum capacitance change with respect to capacitance value at 25 °C	+22%/–56%
Rated DC voltage	25, 50 and 100 V
Dielectric strength	250% of rated voltage
Insulation resistance at rated voltage	10000 MΩ or 1000 MΩ × μF, whichever is less at rated voltage within 2 minutes of charging
Dissipation factor at 1 kHz, 0.5 V	≤4%
Operating temperature range	10 to 85 °C
Storage temperature range	25 ±15 °C
Ageing	typical 6% per time decade
Capacitors with temperature coefficient Y5V	
Capacitance range at 1 kHz, 1 V	0.01 to 1.0 μF
Tolerance on the capacitance	+80%/–20%
Maximum capacitance change with respect to capacitance value at 25 °C	+22%/–82%
Rated DC voltage	25 V and 50 V
Dielectric strength	250% of rated voltage
Insulation resistance at rated voltage	10000 MΩ or 1000 MΩ × μF, whichever is less at rated voltage within 2 minutes of charging
Dissipation factor at 1 kHz, 1 V	≤5%
Operating temperature range	–30 to +85 °C
Storage temperature range	25 ±15 °C
Ageing	typical 6% per time decade

Leaded ceramic multilayer capacitors

Mono-axial™ series

PACKAGING

Table 4 Packaging quantities and box dimensions; see Fig.6

PACKAGING	SIZE CODE	SMALLEST PACKAGING QUANTITY (SPO)	BOX DIMENSIONS L × W × H (mm)
Tape on reel	15; 20	7000	370 × 370 × 90
Ammopack	15; 20	4000	265 × 85 × 95

Capacitors on bandolier

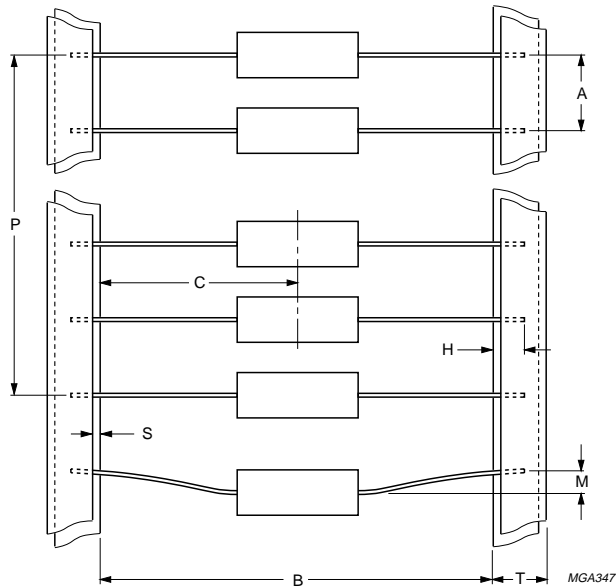

Maximum 0.1% of the total number of capacitors per reel may be missing.
 A maximum of 1 consecutive vacant position is followed by 6 consecutive components.
 Tape begins and ends with minimum of 60 empty positions (300 mm tape).
 Maximum of 5 splices per reel.
 For dimensions see Table 5.

Fig.4 Capacitors on bandolier.

Leaded ceramic multilayer capacitors

Mono-axial™ series

Table 5 Dimensions of bandolier; see Fig.4

SYMBOL	PARAMETER	DIMENSIONS	
		mm	inch
B ⁽¹⁾	inside tape spacing	52.4 ±1.5	2.062 ±0.059
C	centre-to-tape-spacing	±0.8	±0.031
P	cumulative pitch, 6 consecutive components	±1.5	±0.059
A	components pitch	5 ±0.5	0.197 ±0.015
M	lead bend	<1.2	<0.047
S	exposed adhesive	<0.51	<0.020
T	tape width	6.35	0.250
H	lead sandwich	>3.96	>0.156

Note

1. Inside tape spacing 26.0 +1.51/-0.0 is available on request.

REEL DATA

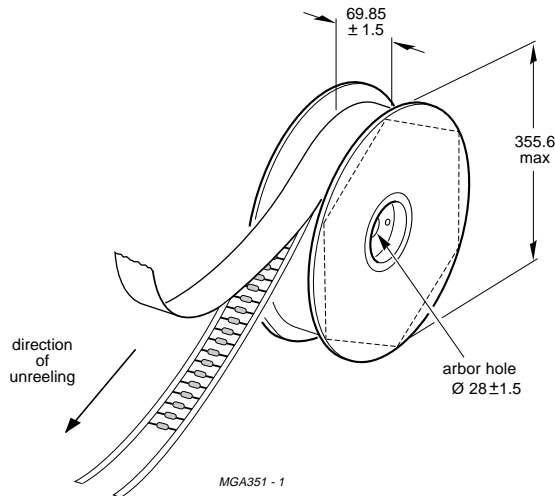

Dimensions in mm.

Maximum 0.1% of the total number of capacitors per reel may be missing.
 A maximum of 1 consecutive vacant position is followed by 6 consecutive components.
 Tape begins and ends with minimum of 60 empty positions (300 mm tape).
 Maximum of 5 splices per reel.
 For capacitor length (L) and diameter (∅D), see Table 1.

Fig.5 Reel with capacitors on tape.

Leaded ceramic multilayer capacitors

Mono-axial™ series

AMMOPACK DATA

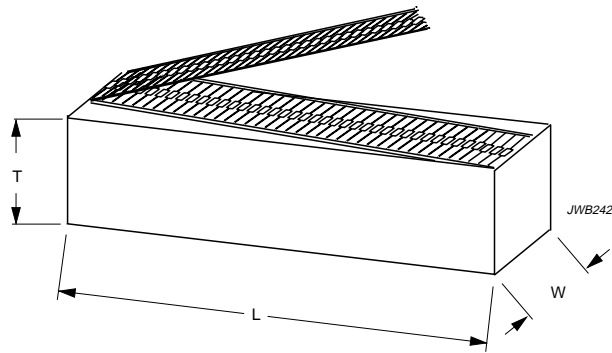

Dimensions in mm.

Maximum 0.5% of the total number of capacitors per box may be missing.

A maximum of 2 consecutive vacant positions is followed by 6 consecutive components.

Tape begins and ends with minimum of 24 empty positions (300 mm tape).

Maximum of 5 splices per box.

Cumulative pitch tolerance over 20 consecutive units not to exceed ± 1.0 mm.

Lead space (F) shall be measured at 3.6 ± 0.5 mm from the capacitor seating plane.

For dimensions see Table 4.

Fig.6 Ammopack with capacitors on tape.