

阅读申明

- 1.本站收集的数据手册和产品资料都来自互联网，版权归原作者所有。如读者和版权方有任何异议请及时告之，我们将妥善解决。
- 2.本站提供的中文数据手册是英文数据手册的中文翻译，其目的是协助用户阅读，该译文无法自动跟随原稿更新，同时也可能存在翻译上的不当。建议读者以英文原稿为参考以便获得更精准的信息。
- 3.本站提供的产品资料，来自厂商的技术支持或者使用者的心得体会等，其内容可能存在描述上的差异，建议读者做出适当判断。
- 4.如需与我们联系，请发邮件到marketing@iczoom.com，主题请标有“数据手册”字样。

Read Statement

1. The datasheets and other product information on the site are all from network reference or other public materials, and the copyright belongs to the original author and original published source. If readers and copyright owners have any objections, please contact us and we will deal with it in a timely manner.
2. The Chinese datasheets provided on the website is a Chinese translation of the English datasheets. Its purpose is for reader's learning exchange only and do not involve commercial purposes. The translation cannot be automatically updated with the original manuscript, and there may also be improper translations. Readers are advised to use the English manuscript as a reference for more accurate information.
3. All product information provided on the website refer to solutions from manufacturers' technical support or users the contents may have differences in description, and readers are advised to take the original article as the standard.
4. If you have any questions, please contact us at marketing@iczoom.com and mark the subject with "Datasheets" .

Ceramic Disc Capacitors

Class 1 and 2, 500 V (DC) General Purpose

FEATURES

- Low losses
- High stability
- High capacitance in small size
- Kinked (preferred) or straight leads.

APPLICATIONS

- Bypassing
- Coupling
- Resonant circuit.

DESIGN

The capacitors consist of a ceramic disc both sides of which are silver-plated. Connection leads are made of tinned copper having a diameter of 0.6 mm.

The capacitors have inward kinked leads with a spacing of 5 mm (0.200") or 7.5 mm (0.300") and a lead length from 4 to 30 mm. Encapsulation is made of phenolic resin.

CAPACITANCE RANGE:

Class 1, at 1 MHz, 1.2 V (RMS); 10 to 82 pF
 1 kHz, 1 ± 0.2 V (RMS) for capacitance values higher than 1000 pF.

Class 2, at 1 kHz, 1 ± 0.2 V (RMS); 100 to 22000 pF

RATED DC VOLTAGE:

500 V

DIELECTRIC STRENGTH:

250 % of rated voltage

INSULATION RESISTANCE AT 500V (DC):

≥ 10000 M Ω

TOLERANCE ON CAPACITANCE:

± 5 %; ± 10 %; ± 20 %; + 80 /- 20 %

DISSIPATION FACTOR:

Class 1, $C \leq 30$ pF; $\leq 20 \times (10/C + 0.7) \times 10^{-4}$ maximum

Class 1, $C > 30$ pF; $\leq 20 \times 10^{-4}$

Class 2, ≤ 3.0 %

TEMPERATURE COEFFICIENTS:

Class 1 C0G (NP0); SLO

Class 2 Y5P; Z5U; Y5V

The capacitors meet the essential requirements of "EIA 198". Unless stated otherwise all electrical values apply at an ambient temperature of 25 ± 3 °C, at normal atmospheric conditions

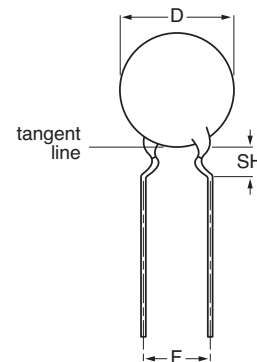

Capacitors with 5 mm (0.20") lead spacing.

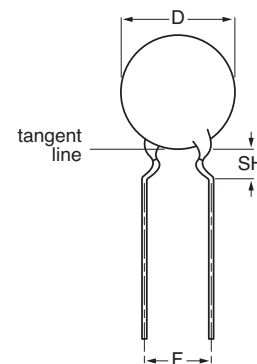

Capacitors with 7.5 mm (0.30") lead spacing.

SECTIONAL SPECIFICATIONS:

Class 1 IEC 60 384-8,

Class 2 IEC 60 384-9,

EIA 198

CLIMATIC CATEGORY:

Class 1 55/125/21

Class 2 10/85/21 and 30/85/21

OPERATING TEMPERATURE RANGE:

Class1 - 55 to +125 °C

Class 2 - 30 to + 85 °C

MARKING

Marking indicates capacitance value and tolerance in accordance with "EIA 198".



ORDERING INFORMATION (PREFERRED TYPES), CLASS 1, 500 V (DC), KINKED

C (pF)	TOL. (%)	D _{max} (mm)	LEAD SPACING F (mm)	SH ⁽²⁾ (mm)	CLEAR TEXT CODE	PACKAGING CODE 8 th AND 9 th DIGIT ⁽³⁾			CATALOG NUMBER ⁽⁴⁾
					13 th DIGIT: T = REEL; U = AMMO; 3 = BULK	REEL	AMMO	BULK	
CLASS 1 NP0									
10	± 5	5.0	5.0	4.0	D100J20C0GL6.J5	06	08	10	2252 508 ..005
12					D120J20C0GL6.J5				2252 508 ..055
15					D150J20C0GL6.J5				2252 508 ..105
18					D180J20C0GL6.J5				2252 508 ..155
22					D220J25C0GL6.J5				2252 508 ..205
27		D270J25C0GL6.J5			2252 508 ..255				
CLASS 1 SL0									
33	± 5	5.0	5.0	4.0	D330J20SL0L6.J5	06	08	10	2252 568 ..305
39					D390J20SL0L6.J5				2252 568 ..355
47					D470J20SL0L6.J5				2252 568 ..405
56					D560J20SL0L6.J5				2252 568 ..505
68					D680J25SL0L6.J5				2252 568 ..605
82		D820J25SL0L6.J5			2252 568 ..805				

Notes

1. Maximum thickness 4.0 mm.
2. SH = seated height.
3. Packaging codes refer to inward kinked leads. Other styles available on request.
4. 8th and 9th digit of the catalog number to be completed with the packaging code.

ORDERING INFORMATION (PREFERRED TYPES), CLASS 2, 500 V (DC), KINKED

C (pF)	TOL. (%)	D _{max} (mm)	LEAD SPACING F (mm)	SH ⁽²⁾ (mm)	CLEAR TEXT CODE	PACKAGING CODE 8 th AND 9 th DIGIT ⁽³⁾			CATALOG NUMBER ⁽⁴⁾
					13 th DIGIT: T = REEL; U = AMMO; 3 = BULK	REEL	AMMO	BULK	
CLASS 2 Y5P									
100	± 10	5.0	5.0	4.0	D101K20Y5PL6.J5	06	08	10	2252 618 ..011
150					D151K20Y5PL6.J5				2252 618 ..111
220					D221K20Y5PL6.J5				2252 618 ..211
330					D331K20Y5PL6.J5				2252 618 ..311
470					D471K20Y5PL6.J5				2252 618 ..411
680					D681K25Y5PL6.J5				2252 618 ..611
1000					D102K25Y5PL6.J5				2252 618 ..021
1500					D152K29Y5PL6.J5				2252 618 ..121
2200					D222K33Y5PL6.J5				2252 618 ..221
3300					D332K39Y5PL6.J5				2252 618 ..321
4700		D472K43Y5PL6.J5			2252 618 ..421				
6800		D682K53Y5PL6.J7			2252 618 ..621				
10000		D103K69Y5PL6.J7			2252 618 ..031				
CLASS 2 Y5V									
1000	+ 80/- 20	5.0	5.0	4.0	D102Z20Y5VL6.J5	06	08	10	2252 638 ..023
1500					D152Z20Y5VL6.J5				2252 638 ..123
2200					D222Z25Y5VL6.J5				2252 638 ..223
3300					D322Z25Y5VL6.J5				2252 638 ..323
4700					D472Z29Y5VL6.J5				2252 638 ..423
6800					D682Z33Y5VL6.J5				2252 638 ..623
10000					D103Z39Y5VL6.J5				2252 638 ..033
15000					D153Z43Y5VL6.J5				2252 638 ..133
22000					D223Z53Y5VL6.J7				2252 638 ..233
33000					D333Z69Y5VL6.J7				2252 638 ..333



ORDERING INFORMATION (PREFERRED TYPES), CLASS 2, 500 V (DC), KINKED									
C (pF)	TOL. (%)	D _{max} (mm)	LEAD SPACING F (mm)	SH ⁽²⁾ (mm)	CLEAR TEXT CODE	PACKAGING CODE 8 th AND 9 th DIGIT ⁽³⁾			CATALOG NUMBER ⁽⁴⁾
					13 th DIGIT: T = REEL; U = AMMO; 3 = BULK	REEL	AMMO	BULK	
CLASS 2 Z5U									
1000	± 20	5.0	5.0	4.0	D102M20Z5UL6.J5	06	08	10	2252 648 ..022
1500					D152M25Z5UL6.J5				2252 648 ..122
2200					D222M25Z5UL6.J5				2252 648 ..222
3300					D332M29Z5UL6.J5				2252 648 ..322
4700					D472M33Z5UL6.J5				2252 648 ..422
6800					D682M39Z5UL6.J5				2252 648 ..622
10000		11.0	7.5	D103M43Z5UL6.J5	2252 648 ..032				
15000		13.5		D153M53Z5UL6.J7	2252 648 ..132				
22000		15.0		D223M59Z5UL6.J7	2252 648 ..232				
				-	-	31			

Notes

1. Maximum thickness 4.0 mm.
2. SH = seated height.
3. Packaging codes refer to inward kinked leads. Other styles available on request.
4. 8th and 9th digit of the catalog number to be completed with the packaging code.

PACKAGING				
D _{max} mm	SIZE CODE	PACKAGING QUANTITIES		
		BULK	REEL	AMMO
5.0 (0.20")	20	1000	2000	2000
6.5 (0.25")	25			
7.5 (0.29")	29			
8.5 (0.33")	33			
10.0 (0.39")	39			
11.0 (0.43")	43			
12.0 (0.47")	47			
13.5 (0.53")	53	500	-	-
15.0 (0.59")	59			
17.5 (0.69")	69			

Note

1. The capacitors are supplied in bulk packaging (cardboard boxes), in tape on reel or in ammpack

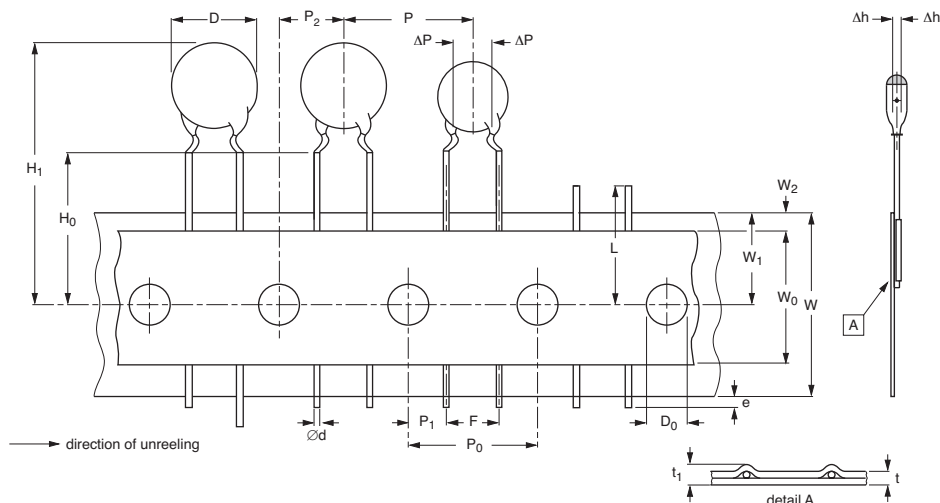

Kinked capacitors on tape, lead spacing 5.0 mm (0.2 inch).

DIMENSIONS OF TAPE			
SYMBOL	PARAMETER	DIMENSIONS (mm)	
		NOMINAL	TOLERANCE
D	body diameter	11.0 maximum	-
d	lead diameter	0.6	± 0.05
P	pitch between capacitors	12.7	± 1.0
P ₀	feed-hole pitch	12.7	± 0.3; note 1
ΔP	plane deviation	1.0 maximum	-
P ₁	feed-hole centre to lead centre	3.85	± 0.7; note 2
P ₂	feed-hole centre to component centre	6.35	± 1.3; note 2
F	lead spacing	5.0	+ 0.6 - 0.4
Δh	component alignment	0	± 1.0
Δs	deviation along tape, left or right	0	± 1.0
W	tape width	18.0	+ 1.0 - 0.5
W ₀	hold-down tape width	5.0 minimum	-
W ₁	hole position	9.0	+ 0.75 - 0.5
W ₂	hold-down tape margin	3.0 maximum	-
H ₀	height to seating plane	16.0	± 0.5
H ₁	maximum component height	32.0	-
e	lead end protrusion	1.0 maximum	-
L	maximum length of snipped lead	11.0	-
D ₀	feed-hole diameter	4.0	± 0.2
t	total tape thickness	0.9 maximum	-
t ₁	maximum thickness of tape and wires	1.5 maximum	-

Notes

1. Cumulative pitch error: $\pm \leq 1 \text{ mm} / 20 \text{ pitches}$.
2. Obliquity maximum 3°.

REEL AND TAPE DATA in millimeters

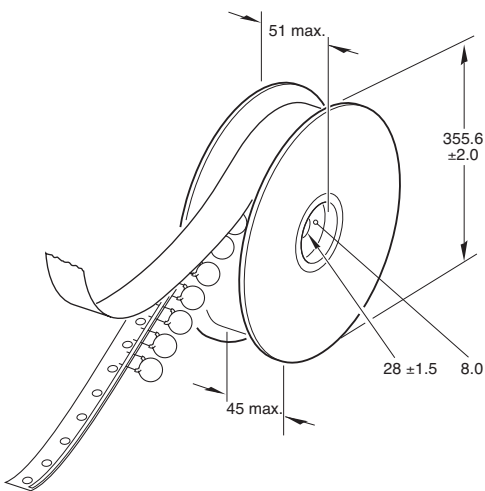

Reel with capacitors on tape.

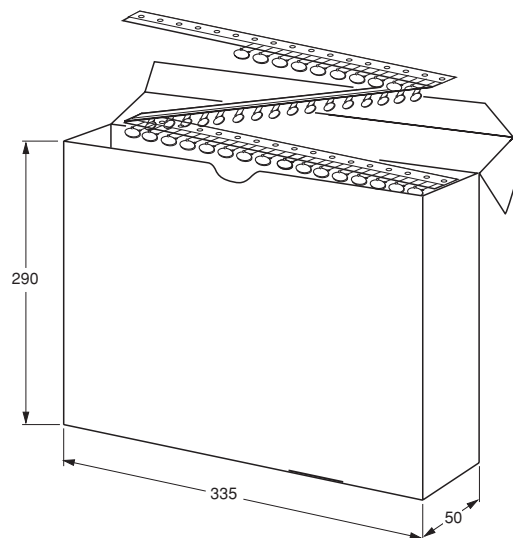

Ampopack with capacitors on tape.