

阅读申明

- 1.本站收集的数据手册和产品资料都来自互联网，版权归原作者所有。如读者和版权方有任何异议请及时告之，我们将妥善解决。
- 2.本站提供的中文数据手册是英文数据手册的中文翻译，其目的是协助用户阅读，该译文无法自动跟随原稿更新，同时也可能存在翻译上的不当。建议读者以英文原稿为参考以便获得更精准的信息。
- 3.本站提供的产品资料，来自厂商的技术支持或者使用者的心得体会等，其内容可能存在描述上的差异，建议读者做出适当判断。
- 4.如需与我们联系，请发邮件到marketing@iczoom.com，主题请标有“数据手册”字样。

Read Statement

1. The datasheets and other product information on the site are all from network reference or other public materials, and the copyright belongs to the original author and original published source. If readers and copyright owners have any objections, please contact us and we will deal with it in a timely manner.
2. The Chinese datasheets provided on the website is a Chinese translation of the English datasheets. Its purpose is for reader's learning exchange only and do not involve commercial purposes. The translation cannot be automatically updated with the original manuscript, and there may also be improper translations. Readers are advised to use the English manuscript as a reference for more accurate information.
3. All product information provided on the website refer to solutions from manufacturers' technical support or users the contents may have differences in description, and readers are advised to take the original article as the standard.
4. If you have any questions, please contact us at marketing@iczoom.com and mark the subject with "Datasheets" .

Mid-high Voltage Ceramic Capacitors

Disk type with lead

Safety standard approved

CS series

Issue date: October 2011

- All specifications are subject to change without notice.
 - Conformity to RoHS Directive: This means that, in conformity with EU Directive 2002/95/EC, lead, cadmium, mercury, hexavalent chromium, and specific bromine-based flame retardants, PBB and PBDE, have not been used, except for exempted applications.
-

Mid-high Voltage Ceramic Capacitors(Disk with Lead) Safety Standard Approved CS Series

Conformity to RoHS Directive

**BASIC INSULATION TYPE/Operating temperature range: -25 to +105°C(UL standard: -25 to +85°C)
CLASS 2 HIGH DIELECTRIC**

FEATURES

- Flame-resistant reinforced outer insulation prevents fires, electrical shock, and other potential hazards.
- Compliant with the safety standards of 11 countries.
- It has a withstand voltage of AC.2600V
- This product is compatible with halogen-free external resin coating (we recommend halogen-free products as standard).

CAPACITANCE TEMPERATURE CHARACTERISTICS AND TOLERANCE

Temperature characteristics	Test temperature range	Capacitance tolerance
B(±10%)	-25 to +85°C	K(±10%)
E(+20, -55%)	-25 to +85°C	M(±20%)
F(+30, -80%)	-25 to +85°C	M(±20%)

PRODUCT IDENTIFICATION

CS	11	-E	2GA	222	M	Y	N	S	A
(1)	(2)	(3)	(4)	(5)	(6)	(7)	(8)	(9)	(10)

- (1) Type
- (2) Shape
- (3) Capacitance temperature characteristics
- (4) Rated voltage
- (5) Nominal capacitance
- (6) Capacitance tolerance
- (7) Class
- (8) Lead type
- (9) Safety standard
- (10) Halogen-free compatible product

CAPACITANCE AND DIMENSIONS

Part No.		Capacitance temperature characteristics	Capacitance (pF)	Capacitance tolerance	Dimensions(mm)				Taping dimensions
Halogen-free product	Current product				D max.	T max.	F	d	
CS70-B2GA101KY□SA	CS70-B2GA101KY□S	B(±10%)	100	K(±10%)	7.0	7.0	7.5±1.5	0.6±0.05	V2
CS70-B2GA151KY□SA	CS70-B2GA151KY□S		150	K(±10%)	7.0	7.0	7.5±1.5	0.6±0.05	V2
CS70-B2GA221KY□SA	CS70-B2GA221KY□S		220	K(±10%)	7.0	7.0	7.5±1.5	0.6±0.05	V2
CS85-B2GA331KY□SA	CS85-B2GA331KY□S		330	K(±10%)	8.5	7.0	7.5±1.5	0.6±0.05	V2
CS85-B2GA471KY□SA	CS85-B2GA471KY□S	E(+20, -55%)	470	K(±10%)	8.5	7.0	7.5±1.5	0.6±0.05	V2
CS95-B2GA681KY□SA	CS95-B2GA681KY□S		680	K(±10%)	9.5	7.0	7.5±1.5	0.6±0.05	V2
CS10-B2GA102KY□SA	CS10-B2GA102KY□S		1,000	K(±10%)	10.0	7.0	7.5±1.5	0.6±0.05	V2
CS80-E2GA102MY□SA	CS80-E2GA102MY□S		1,000	M(±20%)	8.0	7.0	7.5±1.5	0.6±0.05	V2
CS90-E2GA152MY□SA	CS90-E2GA152MY□S	F(+30, -80%)	1,500	M(±20%)	9.0	7.0	7.5±1.5	0.6±0.05	V2
CS11-E2GA222MY□SA	CS11-E2GA222MY□S		2,200	M(±20%)	10.5	7.0	7.5±1.5	0.6±0.05	V2
CS13-E2GA332MY□SA	CS13-E2GA332MY□S		3,300	M(±20%)	12.5	7.0	7.5±1.5	0.6±0.05	V2
CS14-E2GA392MY□SA	CS14-E2GA392MY□S		3,900	M(±20%)	13.5	7.0	7.5±1.5	0.6±0.05	V2
CS15-E2GA472MY□SA	CS15-E2GA472MY□S	F(+30, -80%)	4,700	M(±20%)	14.5	7.0	7.5±1.5	0.6±0.05	V3
CS12-F2GA472MY□SA	CS12-F2GA472MY□S		4,700	M(±20%)	12.0	7.0	7.5±1.5	0.6±0.05	V2
CS17-F2GA103MY□SA	CS17-F2GA103MY□S		10,000	M(±20%)	16.5	7.0	10±2	0.6±0.05	—

* □ : Lead shape symbol

LIST OF STANDARD LEAD SHAPES

The lead type is indicated by the letter which is the 15th character of the product name.

Example) TDK Product Name: **CS11-E2GA222MYNSA**

└N: Lead type (Vertical kink, Short)

Dimensions in mm

	Long lead Symbol G	Short lead Symbol N	Taping Symbol V
Vertical kink			

- We recommend using a vertical kink type.
- For bulk products, we recommend a short lead type with the symbol N.

• Conformity to RoHS Directive: This means that, in conformity with EU Directive 2002/95/EC, lead, cadmium, mercury, hexavalent chromium, and specific bromine-based flame retardants, PBB and PBDE, have not been used, except for exempted applications.

• All specifications are subject to change without notice.

HALOGEN-FREE PRODUCT

MARKINGS

Item	Marking examples
1. Series	CS
2. Nominal capacitance	222(2200pF)
3. Capacitance tolerance	M(±20%)
4. Rated voltage Eac	250V ~ (AC.250V)
5. Sub-class of safety performance	X1Y2
6. TDK's logogram	
7. Date code	15 (2011.5)*

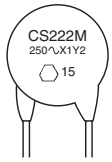
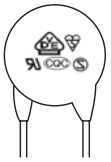
(Marking position is reference.)

* Year and month of production: last digit of year + month denoted by 1, 2, 3, 4, 5, 6, 7, 8, 9, O (October), N (November), or D (December).
 * The expression has become simplified due to a revision in the standards.

INTERNATIONALLY CERTIFIED STATUS / IEC60384-14 EN60384-14 Approved

Safety standard	Standard No. of IEC	Standard No.	Temperature characteristics	Insulation sub-class	Rated voltage Eac(V)	Approval report No.		
						Japan	Taiwan	Xiamen
BSI	IEC 60065	BS EN 60065	B, E, F	X1, Y2	250	KM37103	KM37103	KM37103
	IEC 60384-14	BS EN60384-14						
VDE	IEC 60384-14	EN 60384-14	B, E, F	X1, Y2	250	40029781	40029781	40029781
SEV	IEC 60384-14	EN 60384-14	B, E, F	X1, Y2	250	10.0120	10.0120	10.0120
SEMKO	IEC 60384-14	EN 60384-14	B, E, F	X1, Y2	250	912461	912461	912461
NEMKO	IEC 60384-14	EN 60384-14	B, E, F	X1, Y2	250	P09211677	P09211677	P09211677
DEMKO	IEC 60384-14	EN 60384-14	B, E, F	X1, Y2	250	315269-01	315269-01	315269-01
FIMKO	IEC 60384-14	EN 60384-14	B, E, F	X1, Y2	250	FI 25553	FI 25553	FI 25553
IMQ	IEC 60384-14	EN 60384-14	B, E, F	X1, Y2	250	V3692	V3692	V3692
SAA	IEC 60065	AS3250	B, E, F	—	400	CS6268	CS6268	CS6268
UL	—	UL 1414	B, E, F	(X, Y)	250	E37861	E37861	E37861
CSA	IEC 60384-14	CAN/CSA-E60384-14	B, E, F	(X, Y)	250	2278972 (LR 35801)	2278972 (LR 35801)	2278972 (LR 35801)
CQC	IEC 60384-14	GB-T 14472-1998	B, E, F	X1, Y2	250	CQC10001051610	CQC10001051637	CQC03001004815

• Certificate numbers shall be changed owing to the revisions of the related standards.

CURRENT PRODUCT

MARKINGS

Item	Marking examples
1. Series	CS
2. Nominal capacitance	222(2200pF)
3. Capacitance tolerance	M(±20%)
4. Rated voltage Eac	250V ~ (AC.250V)
5. Withstand voltage Eac	X1Y2
6. Sub-class of safety performance	
7. TDK's logogram	15 (2011.5)*
8. Date code	
9. Regulatory body safety standards compliance markings	

Front



Back

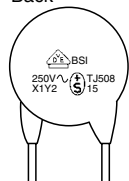

(Marking position of the monogram is reference.)

BSI (U.K.)	BSI	SEV (Switzerland)	TJ508	FIMKO (Finland)		NEMKO (Norway)	
SEMKO (Sweden)		UL (U.S.A.)		DEMKO (Denmark)		IMQ (Italy)	
VDE (Germany)		CSA (Canada)					

* Year and month of production: last digit of year + month denoted by 1, 2, 3, 4, 5, 6, 7, 8, 9, O (October), N (November), or D (December).

INTERNATIONALLY CERTIFIED STATUS / IEC60384-14 EN60384-14 Approved

Safety standard	Standard No. of IEC	Standard No.	Temperature characteristics	Insulation sub-class	Rated voltage Eac(V)	Approval report No.		
						Japan	Taiwan	Xiamen
BSI	IEC 60065	BS EN 60065	B, E, F	X1, Y2	250	226494	226494	226494
	IEC 60384-14	BS EN60384-14						
VDE	IEC 60384-14	EN60384-14	B, E, F	X1, Y2	250	138559	138560	122006
SEV	IEC 60384-14	EN60384-14	B, E, F	X1, Y2	250	09.0962	09.0962	09.0962
SEMKO	IEC 60384-14	EN60384-14	B, E, F	X1, Y2	250	915556	915556	915394
NEMKO	IEC 60384-14	EN60384-14	B, E, F	X1, Y2	250	P09211507	P09211507	P08209309
DEMKO	IEC 60384-14	EN60384-14	B, E, F	X1, Y2	250	315179-01	315179-01	314664-02
FIMKO	IEC 60384-14	EN60384-14	B, E, F	X1, Y2	250	FI 25453	FI 25453	FI 24306A1
IMQ	IEC 60384-14	EN60384-14	B, E, F	X1, Y2	250	V3692	V3692	V3692
SAA	IEC 60065	AS3250	B, E, F	—	400	6268	6268	6268
UL	—	UL 1414	B, E, F	(X, Y)	250	E37861	E37861	E37861
CSA	—	CSA C22.2 No.0 & No.1	B, E, F	(X, Y)	250	LR35801	LR65972	LR65972

• Certificate numbers shall be changed owing to the revisions of the related standards.

• All specifications are subject to change without notice.

TAPING DIMENSIONS

VERTICAL KINK LEAD TYPE

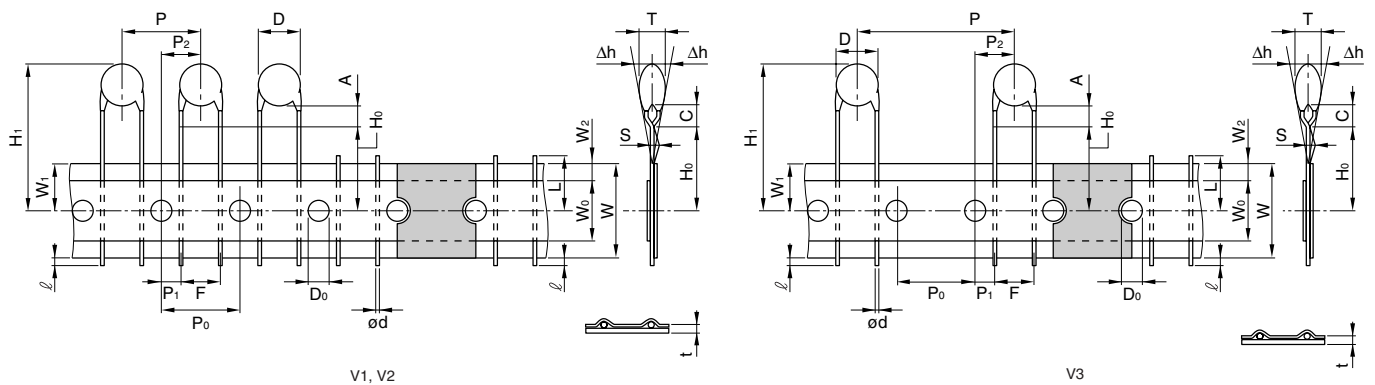

Item	Symbol	Dimensions(mm)			Remarks
		V1	V2	V3	
Body diameter	D	Depends on the specification of each product.			
Body thickness	T	Depends on the specification of each product.			
Lead-wire diameter	ød	0.6±0.05	0.6±0.05	0.6±0.05	
Pitch of component	P	12.7±1.0	15.0±1.0	30.0±1.0	Including the slant of body
Feed hole pitch	P ₀	12.7±0.3	15.0±0.3	15.0±0.3	Excepting the tape splicing part
Feed hole center to lead	P ₁	3.85±0.7	3.75±0.7	3.75±0.7	
Feed hole center to component center	P ₂	6.35±1.3	7.5±1.3	7.5±1.3	
Lead-to lead distance	F	5+0.8, -0.2	7.5±0.8	7.5±0.8	Measuring point is bottom kink
Component alignment	Δh	0±2.0	0±2.0	0±2.0	Including the slanting body due to bending lead-wire
Tape width	W	18.0+1.0, -0.5	18.0+1.0, -0.5	18.0+1.0, -0.5	
Adhesive tape width	W ₀	11.5min.	11.5min.	11.5min.	
Hole position	W ₁	9.0±0.5	9.0±0.5	9.0±0.5	
Adhesive tape position	W ₂	3.0max.	3.0max.	3.0max.	Adhesive tape do not stick out the tape
Bottom of kink from tape center	H ₀	16.0+1.5, -0.5	16.0+1.5, -0.5	16.0+1.5, -0.5	
Height of body from tape center	H ₁	46.0max.	46.0max.	46.0max.	
Lead-wire protrusion	ℓ	1.0max.	1.0max.	1.0max.	
Feed hole diameter	D ₀	4.0±0.2	4.0±0.2	4.0±0.2	
Total tape thickness	t	0.6±0.3	0.6±0.3	0.6±0.3	Do not including adhesive tape
Length of snapped lead	L	11.0max.	11.0max.	11.0max.	
Coating on lead	C	4.0max.	4.0max.	4.0max.	
Height of kink	A	4.0max.	4.0max.	4.0max.	Measuring point is bottom kink
Spring action	S	2.0max.	2.0max.	2.0max.	

• For more information about products with other capacitance or other data, please contact us.

• All specifications are subject to change without notice.