

阅读申明

- 1.本站收集的数据手册和产品资料都来自互联网，版权归原作者所有。如读者和版权方有任何异议请及时告之，我们将妥善解决。
- 2.本站提供的中文数据手册是英文数据手册的中文翻译，其目的是协助用户阅读，该译文无法自动跟随原稿更新，同时也可能存在翻译上的不当。建议读者以英文原稿为参考以便获得更精准的信息。
- 3.本站提供的产品资料，来自厂商的技术支持或者使用者的心得体会等，其内容可能存在描述上的差异，建议读者做出适当判断。
- 4.如需与我们联系，请发邮件到marketing@iczoom.com，主题请标有“数据手册”字样。

Read Statement

1. The datasheets and other product information on the site are all from network reference or other public materials, and the copyright belongs to the original author and original published source. If readers and copyright owners have any objections, please contact us and we will deal with it in a timely manner.
2. The Chinese datasheets provided on the website is a Chinese translation of the English datasheets. Its purpose is for reader's learning exchange only and do not involve commercial purposes. The translation cannot be automatically updated with the original manuscript, and there may also be improper translations. Readers are advised to use the English manuscript as a reference for more accurate information.
3. All product information provided on the website refer to solutions from manufacturers' technical support or users the contents may have differences in description, and readers are advised to take the original article as the standard.
4. If you have any questions, please contact us at marketing@iczoom.com and mark the subject with "Datasheets" .

Thin Film Capacitors(Z-match)

For Impedance Matching at High Frequency

TFSQ Series

Type: TFSQ0402 (0.4×0.2×0.2mm)

Issue date: August 2011

- All specifications are subject to change without notice.
 - Conformity to RoHS Directive: This means that, in conformity with EU Directive 2002/95/EC, lead, cadmium, mercury, hexavalent chromium, and specific bromine-based flame retardants, PBB and PBDE, have not been used, except for exempted applications.
-

Thin Film Capacitors(Z-match) TFSQ0402 Series

Conformity to RoHS Directive

SHAPES AND DIMENSIONS

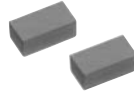
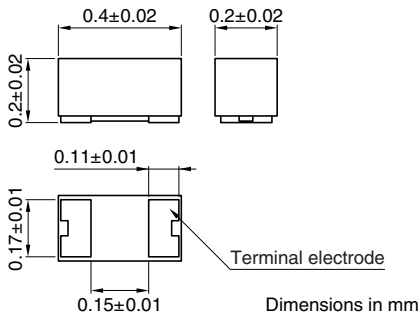

PRODUCT IDENTIFICATION

TFSQ0402	C0H	1C	3R0	W	T
(1)	(2)	(3)	(4)	(5)	(6)

(1) Series name

(2) Capacitance temperature characteristics
Class 1 (Temperature compensation)

Temperature characteristics	Capacitance change	Temperature range
C0H	0±60ppm/°C	-55 to +125°C

(3) Rated voltage E_{dc}

1C	16V
----	-----

(4) Nominal capacitance

The capacitance is expressed in three digit codes and in units of pico farads (pF).

The first and second digits identify the first and second significant figures of the capacitance.

The third digit identifies the multiplier.

R designates a decimal point.

0R2	0.2pF
3R0	3.0pF

(5) Capacitance tolerance

Symbol	Tolerance
W	±0.05pF
B	±0.1pF

(6) Packaging style

T	Taping (reel)
---	---------------

- This specification is applicable to thin film capacitors with a priority over the other relevant specifications. Production places defined in this specification should be TDK-EPC Corporation Japan.
- This specification warrants the quality of the thin film capacitors. The chips should be evaluated or confirmed a state of mounted on your product. If the use of the chips goes beyond the bounds of the specification, we can not afford to guarantee.
- Conformity to RoHS Directive: This means that, in conformity with EU Directive 2002/95/EC, lead, cadmium, mercury, hexavalent chromium, and specific bromine-based flame retardants, PBB and PBDE, have not been used, except for exempted applications.
- All specifications are subject to change without notice.

CAPACITANCE RANGES: CLASS 1 (TEMPERATURE COMPENSATION)
TEMPERATURE CHARACTERISTICS: C0H(0±60ppm/°C)

 RATED VOLTAGE E_{dc}: 16V

Capacitance (pF)	Tolerance (pF)	Q typ. [at 2GHz]	SRF (GHz)typ.	Part No. Temperature characteristics:C0H
0.2	±0.05	296	21.0	TFSQ0402C0H1C0R2WT
0.3	±0.05	350	17.4	TFSQ0402C0H1C0R3WT
0.4	±0.05	428	15.2	TFSQ0402C0H1C0R4WT
0.5	±0.05	390	13.7	TFSQ0402C0H1C0R5WT
0.6	±0.05	429	12.5	TFSQ0402C0H1C0R6WT
0.7	±0.05	429	11.7	TFSQ0402C0H1C0R7WT
0.8	±0.05	453	11.0	TFSQ0402C0H1C0R8WT
0.9	±0.05	430	10.4	TFSQ0402C0H1C0R9WT
1.0	±0.05	356	9.9	TFSQ0402C0H1C1R0WT
1.1	±0.05	356	9.4	TFSQ0402C0H1C1R1WT
1.2	±0.05	357	9.1	TFSQ0402C0H1C1R2WT
1.3	±0.05	339	8.7	TFSQ0402C0H1C1R3WT
1.4	±0.05	336	8.4	TFSQ0402C0H1C1R4WT
1.5	±0.05	321	8.2	TFSQ0402C0H1C1R5WT
1.6	±0.05	311	7.9	TFSQ0402C0H1C1R6WT
1.7	±0.05	312	7.7	TFSQ0402C0H1C1R7WT
1.8	±0.05	307	7.5	TFSQ0402C0H1C1R8WT
1.9	±0.05	292	7.3	TFSQ0402C0H1C1R9WT
2.0	±0.05	293	7.1	TFSQ0402C0H1C2R0WT
2.1	±0.05	280	7.0	TFSQ0402C0H1C2R1WT
2.2	±0.05	273	6.8	TFSQ0402C0H1C2R2WT
2.3	±0.05	261	6.7	TFSQ0402C0H1C2R3WT
2.4	±0.05	244	6.5	TFSQ0402C0H1C2R4WT
2.5	±0.05	246	6.4	TFSQ0402C0H1C2R5WT
2.6	±0.05	240	6.3	TFSQ0402C0H1C2R6WT
2.7	±0.05	215	6.2	TFSQ0402C0H1C2R7WT
2.8	±0.05	224	6.1	TFSQ0402C0H1C2R8WT
2.9	±0.05	219	6.0	TFSQ0402C0H1C2R9WT
3.0	±0.05	194	5.9	TFSQ0402C0H1C3R0WT

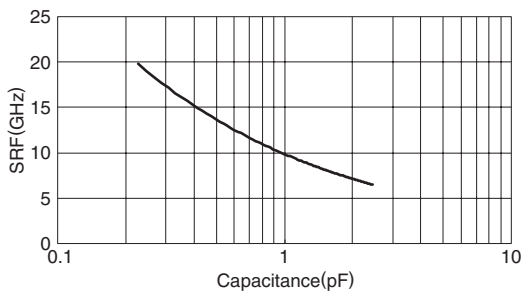
TYPICAL ELECTRICAL CHARACTERISTICS
SRF vs. CAPACITANCE CHARACTERISTICS

- Measurement condition
- Network analyzer: Agilent N5230A
 - Calibration: TRL
 - PCB: Shunt-Thru
t=0.4mm ε_r=2.17



PACKAGING STYLES
REEL DIMENSIONS

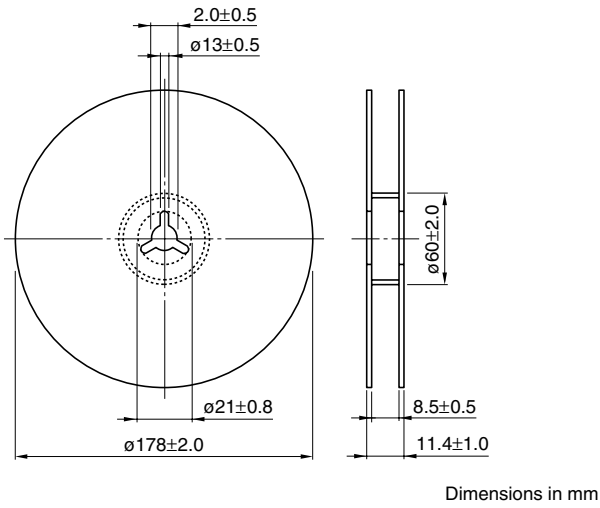

TAPE DIMENSIONS

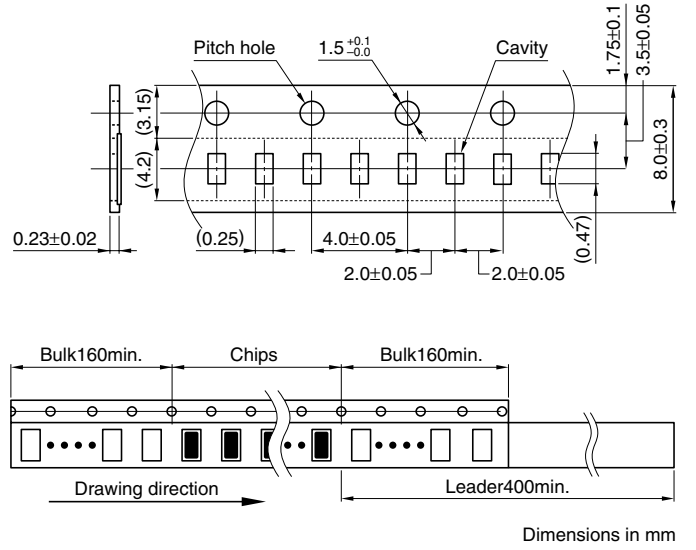

• All specifications are subject to change without notice.