

阅读申明

- 1.本站收集的数据手册和产品资料都来自互联网，版权归原作者所有。如读者和版权方有任何异议请及时告之，我们将妥善解决。
- 2.本站提供的中文数据手册是英文数据手册的中文翻译，其目的是协助用户阅读，该译文无法自动跟随原稿更新，同时也可能存在翻译上的不当。建议读者以英文原稿为参考以便获得更精准的信息。
- 3.本站提供的产品资料，来自厂商的技术支持或者使用者的心得体会等，其内容可能存在描述上的差异，建议读者做出适当判断。
- 4.如需与我们联系，请发邮件到marketing@iczoom.com，主题请标有“数据手册”字样。

Read Statement

1. The datasheets and other product information on the site are all from network reference or other public materials, and the copyright belongs to the original author and original published source. If readers and copyright owners have any objections, please contact us and we will deal with it in a timely manner.
2. The Chinese datasheets provided on the website is a Chinese translation of the English datasheets. Its purpose is for reader's learning exchange only and do not involve commercial purposes. The translation cannot be automatically updated with the original manuscript, and there may also be improper translations. Readers are advised to use the English manuscript as a reference for more accurate information.
3. All product information provided on the website refer to solutions from manufacturers' technical support or users the contents may have differences in description, and readers are advised to take the original article as the standard.
4. If you have any questions, please contact us at marketing@iczoom.com and mark the subject with "Datasheets" .

FILMTRIM[®] PLASTIC DIELECTRIC CAPACITORS

TYPES

- Six Dielectrics:
 - High temperature PTFE
 - Standard PTFE
 - Polypropylene
 - Polyimide
 - Polycarbonate
 - Polyphenyl sulfide
- SMD and lead-through-hole mounting
- Top, bottom and side mount models
- Wide capacitance ranges
- Compact sizes
- Low cost for commercial/industrial applications
- Linear capacitance change vs. rotation

APPLICATIONS

- Mobile Radios
- Transmitters
- Pagers
- Instruments
- Electronic Games
- Wireless Security and Fire Alarms
- CATV



MODIFICATIONS AND VARIATIONS AVAILABLE

- Special capacitance ranges
- Special terminal sizes and shapes
- Extended adjust shafts
- High temperature versions for PTFE
- Silver and/or gold plating



Sprague-Goodman Electronics, Inc.

1700 SHAMES DRIVE, WESTBURY, NY 11590

TEL: 516-334-8700 • FAX: 516-334-8771

E-MAIL: info@spraguegoodman.com

5mm TOP ADJUST

FEATURES

- High temperature PTFE or polyimide (PI) dielectrics
- Compact size
- Linear capacitance change vs. rotation

SPECIFICATIONS

Voltage Rating: 150 VDC
 Dielectric Withstanding Voltage: 300 VDC
 Contact Resistance: 0.010 Ohms max
 Insulation Resistance: 10⁴ megohms min
 Torque: 15 to 200 g-cm (0.21 to 3 oz-in)

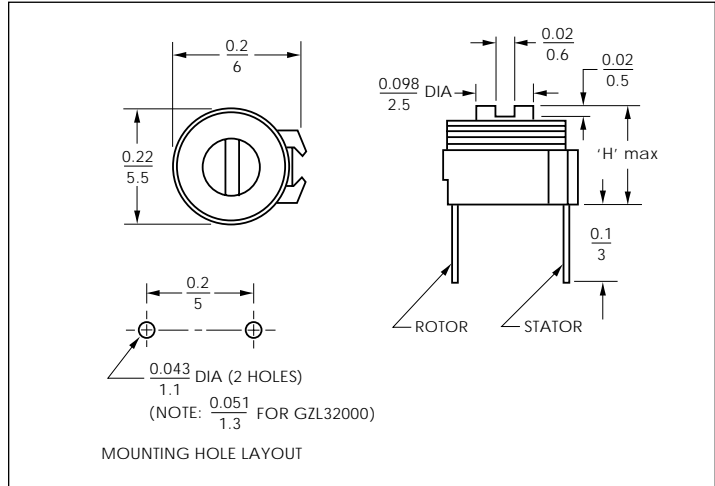

All dimensions are in /mm.



Dielectric	Capacitance (pF)		Q min (1MHz)	TCC (ppm / °C)	Operating Temperature (°C)	'H' max in/mm	Color Code	Model Number
	min	max						
PTFE, High Temp	1.2	4.0	1500	0 ± 350	-40 to +125	0.20 / 5.0	Brown	GXL4R000
	1.8	10.0	1500	0 ± 300	-40 to +125	0.23 / 5.8	Black	GXL10000
	2.0	15.0	1500	0 ± 300	-40 to +125	0.24 / 6.0	White	GXL15000
	2.3	18.0	1500	0 ± 300	-40 to +125	0.24 / 6.0	Green	GXL18000
PI	1.2	5.0	150	0 ± 350	-40 to +85	0.20 / 5.0	Brown	GZL5R000
	1.4	10.0	150	0 ± 350	-40 to +85	0.20 / 5.0	Black	GZL10000
	2.0	15.0	150	0 ± 250	-40 to +85	0.23 / 5.8	White	GZL15000
	2.7	20.0	150	0 ± 250	-40 to +85	0.23 / 5.8	Green	GZL20000
	3.6	32.0	150	0 ± 250	-40 to +85	0.25 / 6.3	None	GZL32000

ECONOMY 7 mm TOP ADJUST

SPECIFICATIONS

Operating Temperature Range: -25°C to +85°C
 Dielectric: Polyphenyl Sulfide
 Voltage Rating: 50 VDC
 Dielectric Withstanding Voltage: 100 VDC
 Insulation Resistance: 500 megohms min
 Torque: 20 - 200 g-cm (0.28 - 2.8 oz-in)

FEATURES

- Low setting drift
- High Q
- Low cost
- Compact size

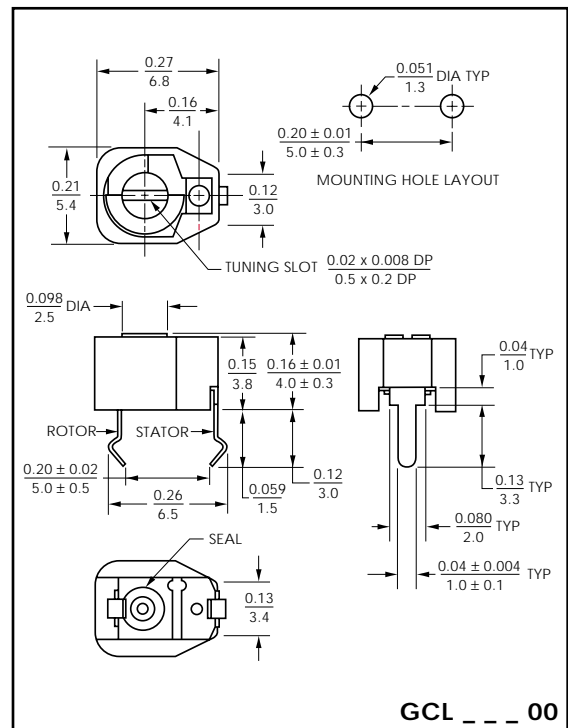

Capacitance (pF)		TCC (ppm / °C)	Q min (1 MHz)	Color Code	Bulk Pack Model Number	Ammo Pack Model Number
min	max					
0.7	10.0	350 ± 500	500	Brown	GCL10000	GCL10025
0.8	20.0	350 ± 500	500	Green	GCL20000	GCL20025
0.9	30.0	350 ± 500	500	Yellow	GCL30000	GCL30025
1.0	40.0	350 ± 500	500	Blue	GCL40000	GCL40025

7 mm SURFACE MOUNT

FEATURES

- Low setting drift
- High Q
- Low cost
- Linear Capacitance change vs. rotation
- Compact size



Capacitance (pF)		'H' max (in/mm)	Color Code	Model Number
min	max			
0.5	4.5	0.087 / 2.2	Orange	GSX364
0.6	9.0	0.087 / 2.2	Black	GSX358
0.8	15.0	0.094 / 2.4	Blue	GSX365
1.0	20.0	0.100 / 2.6	Green	GSX366

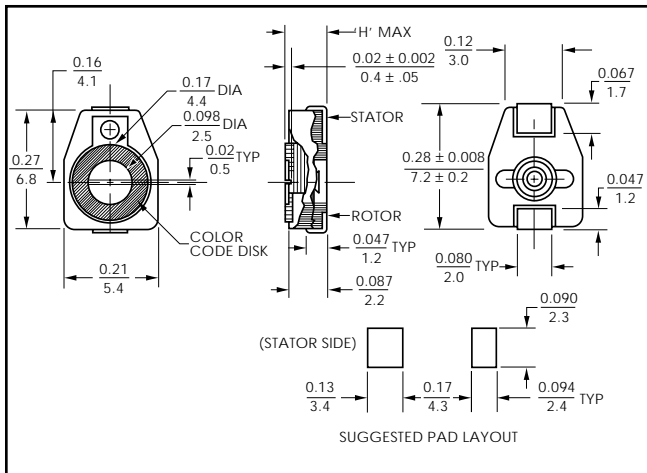

SPECIFICATIONS

Q min (at 10 MHz): 1000
 Operating Temperature Range: -25°C to +85°C
 Dielectric: PTFE
 TCC: N100 ± 100 ppm/°C
 Voltage Rating: 100 VDC
 Dielectric Withstanding Voltage: 200 VDC
 Insulation Resistance: 10⁴ megohms min
 Torque: 20-300 g-cm (0.28 - 4.2 oz-in)

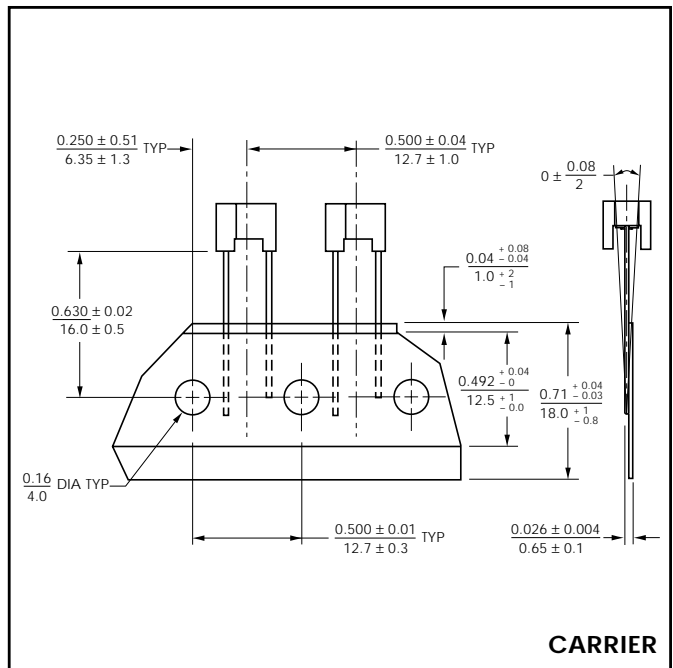
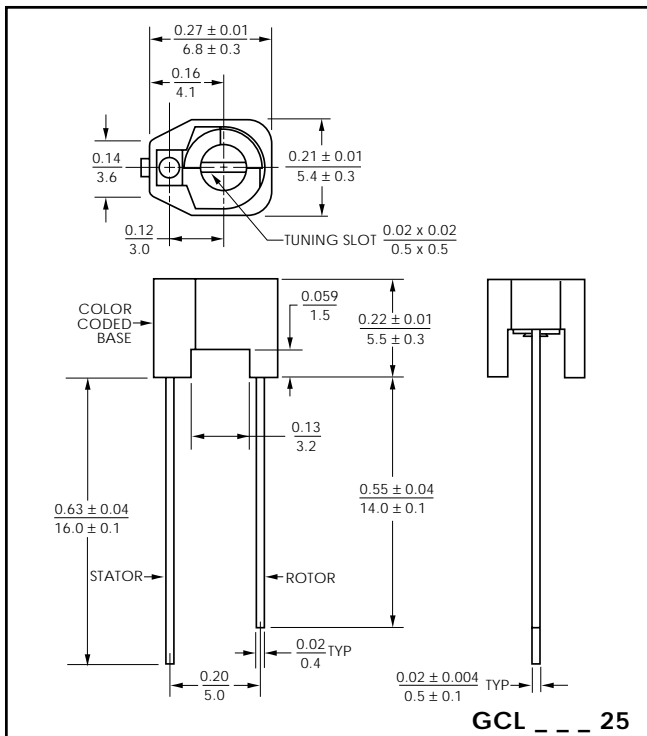
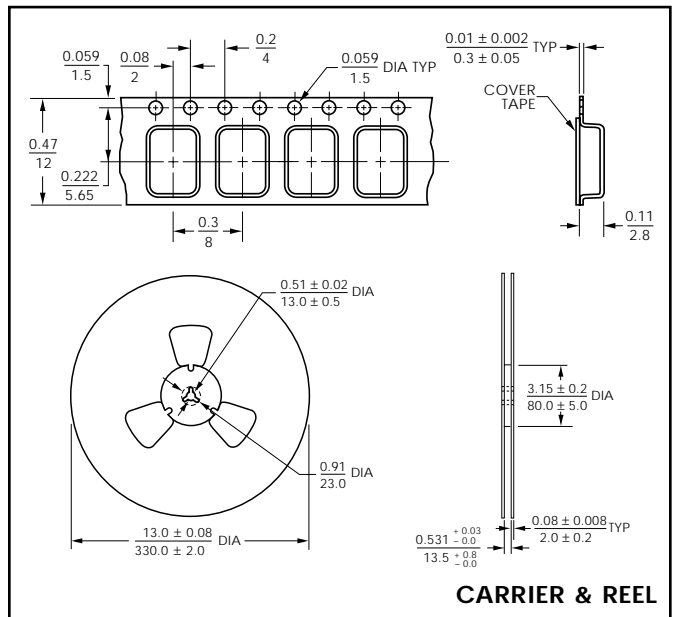

All dimensions are in / mm.

7 mm SURFACE MOUNT NONMAGNETIC

FEATURES

- Low setting drift
- High Q
- Low cost
- Linear Capacitance change vs. rotation
- Compact size

SPECIFICATIONS

Relative Permeability: 1.0025 max
 Q min (at 10 MHz): 1000
 Operating Temperature Range: -25°C to +85°C
 Dielectric: PTFE
 TCC: N100 ± 100 ppm/°C
 Voltage Rating: 100 VDC
 Dielectric Withstanding Voltage: 200 VDC
 Insulation Resistance: 10⁴ megohms min
 Torque: 20-300 g-cm (0.28 - 4.2 oz-in)



Capacitance (pF)		'H' max (in/mm)	Color Code	Model Number
min	max			
0.5	4.5	0.087 / 2.2	Orange	GSX364NM
0.6	9.0	0.087 / 2.2	Black	GSX358NM
0.8	15.0	0.094 / 2.4	Blue	GSX365NM
1.0	20.0	0.100 / 2.6	Green	GSX366NM

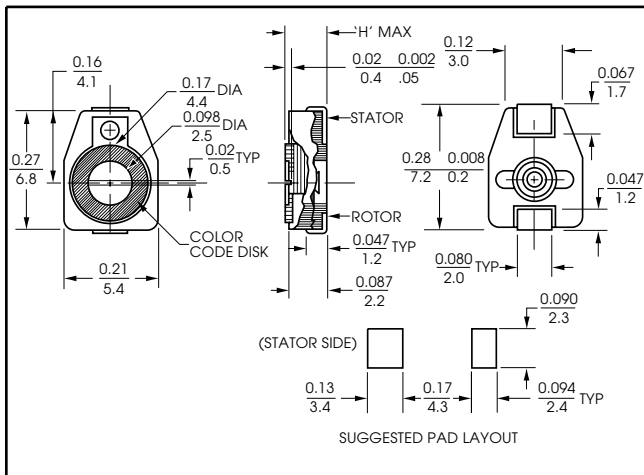

All dimensions are in / mm.

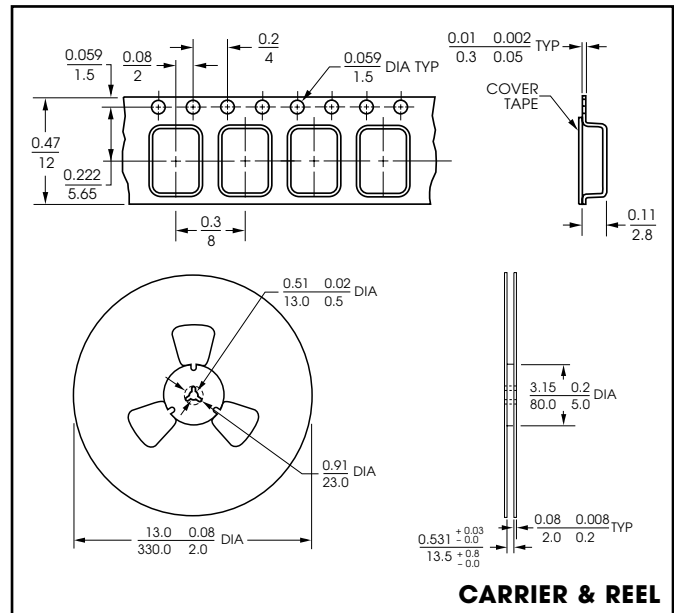

CARRIER & REEL

6 X 8 mm TOP/BOTTOM & SIDE ADJUST

FEATURES

- Compact size
- High temperature PTFE dielectric
- Linear capacitance change vs. rotation

SPECIFICATIONS

Voltage Rating: 300 VDC

Dielectric Withstanding Voltage: 500 VDC

Contact Resistance: 0.010 Ohms max

Insulation Resistance: 10⁴ megohms min

Torque: 15 to 245 g-cm (0.21 to 3.4 oz-in)



Dielectric	Capacitance (pF)		Q min (1MHz)	TCC (ppm / °C)	Operating Temperature (°C)	Color Code	Top/Bottom Adjust	Top/Bottom Adjust	Side Adjust
	min	max					3 Lead Model Number	2 Lead Model Number	Model Number
PTFE, High Temp	1.0	3.5	1500	0 ± 350	-40 to +125	Orange	GXE3R511	GXE3R501	GXQ3R501
	1.8	10.0	1500	0 ± 350	-40 to +125	White	GXE10011	GXE10001	GXQ10001
	2.5	18.0	1500	0 ± 350	-40 to +125	Red	GXE18011	GXE18001	GXQ18001

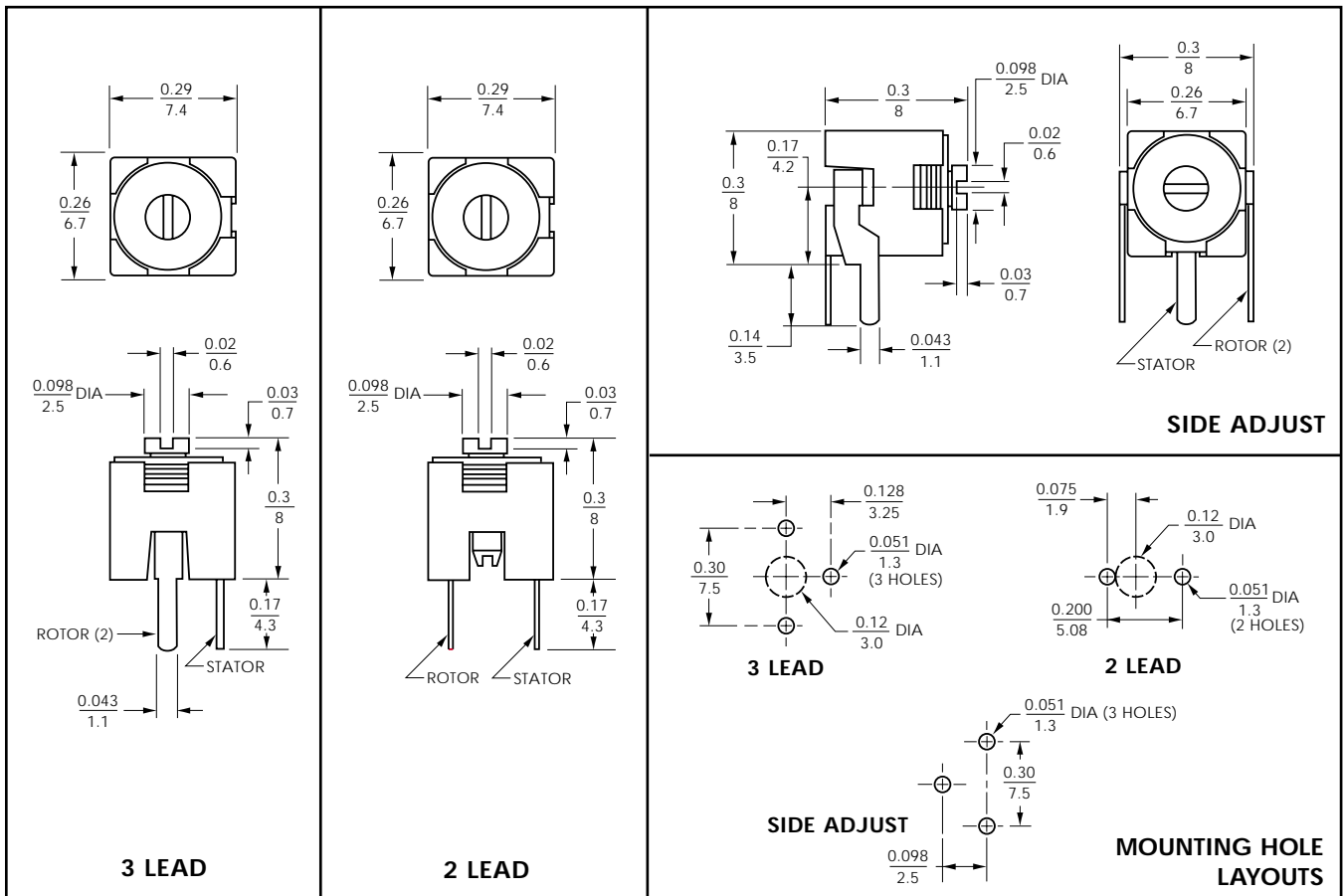

All dimensions are in / mm.

8 mm TOP/BOTTOM & SIDE ADJUST

SPECIFICATIONS

Voltage Rating: 200 VDC (High temp PTFE),
100 VDC (all others)

Dielectric Withstanding Voltage:
300 VDC (High temp PTFE), 200 VDC (all others)

Contact Resistance: 0.010 Ohms max

Insulation Resistance: 10⁴ megohms min

Torque: 15 to 250 g-cm (0.21 to 3.5 oz-in)

FEATURES

- Choice of dielectrics: High Temp PTFE, Standard PTFE, Polypropylene, or Polycarbonate
- Linear capacitance change vs. rotation



Dielectric	Capacitance (pF)		Q min (1MHz)	TCC (ppm/°C)	Operating Temperature (°C)	'H' max in/mm	Color Code	Top/Bottom Adjust 3 Lead	Top/Bottom Adjust 2 Lead	Side Adjust
	min	max						Model Number	Model Number	Model Number
PTFE*, High Temp	1.5	5.0	1500	0 ± 250	-40 to +125	.402/10.2	Clear	GXE5R000	GXE5R002	GXR5R000
	1.8	9.0	1500	0 ± 250	-40 to +125	.402/10.2	Yellow	GXE9R000	GXE9R002	GXR9R000
	2.6	18.0	1500	0 ± 250	-40 to +125	.402/10.2	Green	GXE18000	GXE18002	GXR18000
	3.5	27.0	1500	0 ± 250	-40 to +125	.402/10.2	Red	GXE27000	GXE27002	GXR27000
	4.5	36.0	1500	0 ± 250	-40 to +125	.449/11.4	Violet	GXE36000	GXE36002	GXR36000
	5.0	45.0	1500	0 ± 250	-40 to +125	.449/11.4	Orange	GXE45000	GXE45002	GXR45000
PTFE	1.6	5.0	1500	0 ± 350	-40 to +85	.402/10.2	Clear	GXA5R000	GXA5R002	GXB5R000
	2.0	9.0	1500	0 ± 350	-40 to +85	.402/10.2	Yellow	GXA9R000	GXA9R002	GXB9R000
	2.0	18.0	1500	0 ± 300	-40 to +85	.402/10.2	Green	GXA18000	GXA18002	GXB18000
	3.9	27.0	1500	0 ± 300	-40 to +85	.402/10.2	Red	GXA27000	GXA27002	GXB27000
	4.5	36.0	1500	0 ± 300	-40 to +85	.449/11.4	Violet	GXA36000	GXA36002	GXB36000
	5.0	45.0	1500	0 ± 300	-40 to +85	.449/11.4	Orange	GXA45000	GXA45002	GXB45000
PP	1.6	5.0	1000	0 ± 300	-40 to +70	.402/10.2	Clear	GYA5R000	GYA5R002	GYB5R000
	2.0	10.0	1000	0 ± 300	-40 to +70	.402/10.2	Yellow	GYA10000	GYA10002	GYB10000
	2.0	15.0	1000	0 ± 400	-40 to +70	.402/10.2	Blue	GYA15000	GYA15002	GYB15000
	2.2	22.0	1000	0 ± 400	-40 to +70	.402/10.2	Green	GYA22000	GYA22002	GYB22000
	2.3	27.0	1000	0 ± 350	-40 to +70	.402/10.2	Red	GYA27000	GYA27002	GYB27000
	3.0	36.0	1000	0 ± 300	-40 to +70	.402/10.2	Violet	GYA36000	GYA36002	N/A
PC	2.5	30.0	200	100 ± 300	-40 to +85	.402/10.2	Red	GZA30000	GZA30002	GZB30000
	4.0	40.0	200	100 ± 300	-40 to +85	.402/10.2	Violet	GZA40000	GZA40002	GZB40000

* Gold plated metal parts are standard on GXE and GXR models shown above.

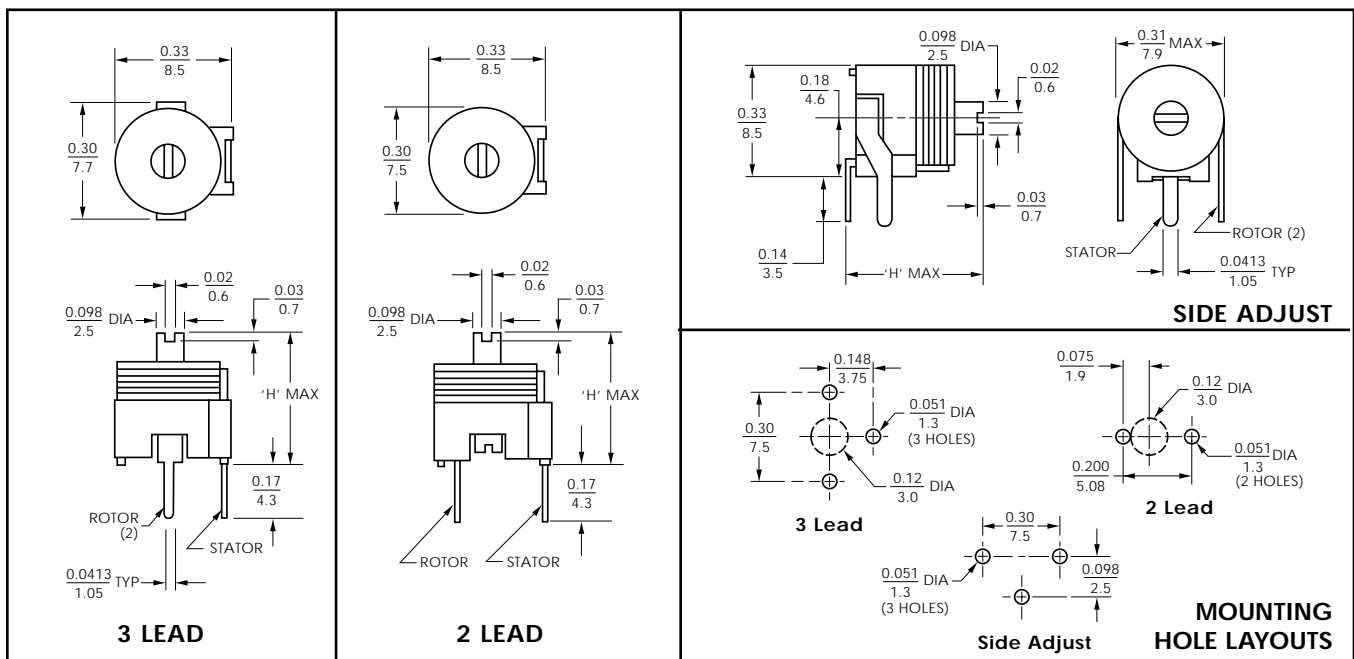

All dimensions are in / mm.

10 mm TOP/BOTTOM & SIDE ADJUST

SPECIFICATIONS

Voltage Rating: 200 VDC (High temp PTFE),
100 VDC (all others)

Dielectric Withstanding Voltage:
300 VDC (High temp PTFE), 200 VDC (all others)

Contact Resistance: 0.010 Ohms max

Insulation Resistance: 10⁴ megohms min

Torque: 15 to 360 g-cm (0.2 to 5 oz-in)

FEATURES

- Choice of dielectrics: High Temp PTFE, Standard PTFE, Polypropylene (PP), or Polycarbonate (PC)
- Linear capacitance change vs. rotation
- Wide capacitance ranges

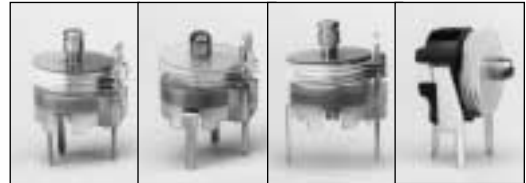

Dielectric	Capacitance (pF)		Q min (1MHz)	TCC (ppm/°C)	Operating Temperature (°C)	'H' max in/mm	Color Code	Top/Bottom	Top/Bottom	Top/Bottom	Side
	min	max						3 Lead-Std. Model No.	3 Lead-Spec. Model No.	2 Leads Model No.	Model No.
PTFE*, High Temp	2.5	15.0	1500	0 ± 250	-40 to +125	0.402/10.2	Red	GXF15000	GXF15003	GXF15004	GXT15000
	3.0	25.0	1500	0 ± 250	-40 to +125	0.402/10.2	Clear	GXF25000	GXF25003	GXF25004	GXT25000
	4.0	40.0	1500	0 ± 250	-40 to +125	0.402/10.2	Yellow	GXF40000	GXF40003	GXF40004	GXT40000
	5.5	60.0	1500	0 ± 250	-40 to +125	0.449/11.4	Blue	GXF60000	GXF60003	GXF60004	GXT60000
	6.0	75.0	1500	0 ± 250	-40 to +125	0.449/11.4	Violet	GXF75000	GXF75003	GXF75004	GXT75000
	8.0	90.0	1500	0 ± 250	-40 to +125	0.488/12.4	Orange	GXF90000	GXF90003	GXF90004	GXT90000
PTFE	2.0	13.0	1500	0 ± 400	-40 to +85	0.402/10.2	Blue	GXC13000	GXC13003	GXC13004	GXD13000
	3.0	26.0	1500	0 ± 350	-40 to +85	0.402/10.2	Green	GXC26000	GXC26003	GXC26004	GXD26000
	3.5	38.0	1500	0 ± 300	-40 to +85	0.402/10.2	Clear	GXC38000	GXC38003	GXC38004	GXD38000
	6.0	60.0	1500	0 ± 300	-40 to +85	0.449/11.4	Yellow	GXC60000	GXC60003	GXC60004	GXD60000
	7.0	75.0	1500	0 ± 300	-40 to +85	0.449/11.4	Red	GXC75000	GXC75003	GXC75004	GXD75000
	8.0	90.0	1500	0 ± 300	-40 to +85	0.488/12.4	Violet	GXC90000	GXC90003	GXC90004	GXD90000
10.0	150.0	1500	0 ± 300	-40 to +85	0.488/12.4	Orange	GXC15100	GXC15103	GXC15104	N/A	
PP	2.0	15.0	1000	0 ± 400	-40 to +70	0.402/10.2	Blue	GYC15000	GYC15003	GYC15004	GXD15000
	3.0	20.0	1000	0 ± 400	-40 to +70	0.402/10.2	Green	GYC20000	GYC20003	GYC20004	GXD20000
	3.5	40.0	1000	0 ± 350	-40 to +70	0.402/10.2	Clear	GYC40000	GYC40003	GYC40004	GXD40000
	4.5	65.0	1000	0 ± 350	-40 to +70	0.402/10.2	Yellow	GYC65000	GYC65003	GYC65004	GXD65000
PC	8.0	80.0	200	0 ± 200	-40 to +85	0.402/10.2	Red	GZC80000	GZC80003	GZC80004	GZD80000
	9.0	100.0	200	0 ± 400	-40 to +85	0.449/11.4	Violet	GZC10100	GZC10103	GZC10104	GZD10100
	9.0	120.0	200	0 ± 350	-40 to +85	0.449/11.4	Orange	GZC12100	GZC12103	GZC12104	GZD12100
	10.0	150.0	200	0 ± 350	-40 to +85	0.472/12.0	Orange	GZC15100	GZC15103	GZC15104	GZD15100
	12.0	180.0	200	0 ± 350	-40 to +85	0.472/12.0	Orange	GZC18100	GZC18103	GZC18104	GZD18100

* Gold plated metal parts are standard on GXF and GXT models shown above.

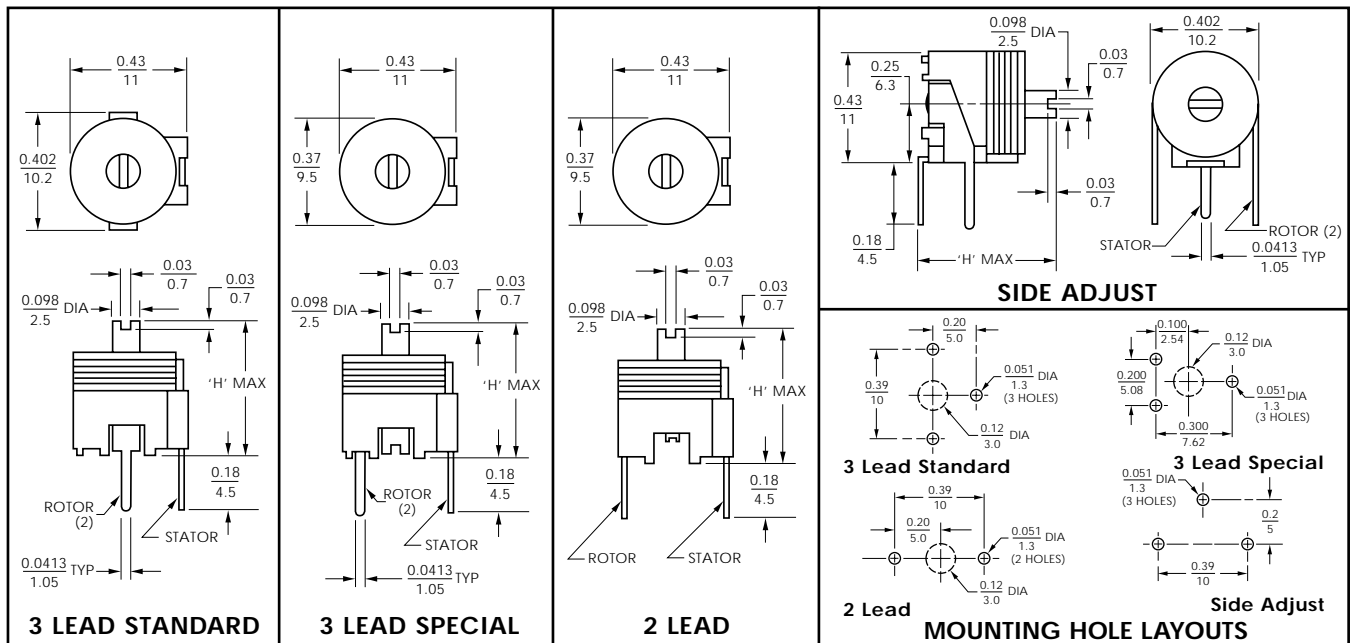

All dimensions are in / mm.

11 X 13 mm TOP/BOTTOM ADJUST

FEATURES

- Housing protected
- High capacitance range
- Linear capacitance change vs. rotation

SPECIFICATIONS

Voltage Rating: 100 VDC
 Dielectric Withstanding Voltage: 200 VDC
 Contact Resistance: 0.010 Ohms max
 Insulation Resistance: 10⁴ megohms min
 Torque: 20 to 360 g-cm (0.28 to 5 oz-in)

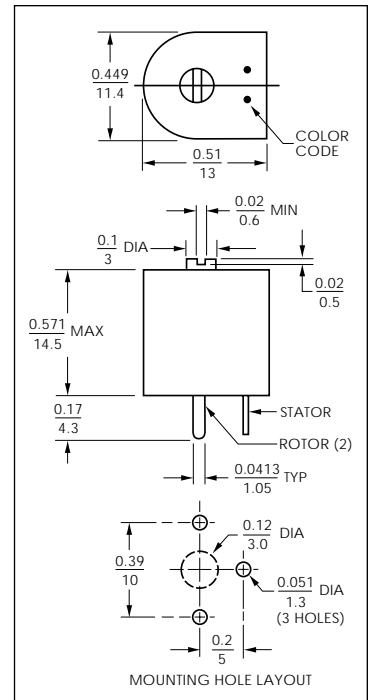

Dielectric	Capacitance (pF)		Q min (1MHz)	TCC (ppm/°C)	Operating Temperature (°C)		Color Code	Model Number
	min	max			-40 to +85	-40 to +85		
PC	15.0	230.0	200	0 ± 400	-40 to +85		Orange - 1 dot	GZC23112
	30.0	430.0	150	0 ± 350	-40 to +85		Orange - 2 dot	GZC43112

16 mm TOP / SIDE ADJUST

FEATURES

- Highest capacitance range
- Linear capacitance change vs. rotation

SPECIFICATIONS

Voltage Rating: 150 VDC
 Dielectric Withstanding Voltage: 300 VDC
 Contact Resistance: 0.010 Ohms max
 Insulation Resistance: 10⁴ megohms min
 Torque: 20 to 360 g-cm (0.28 to 5 oz-in)

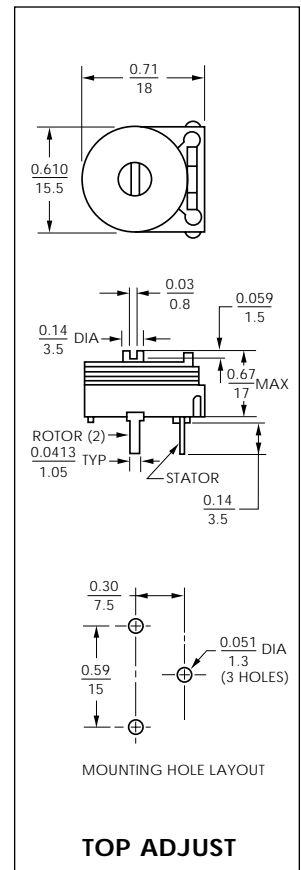
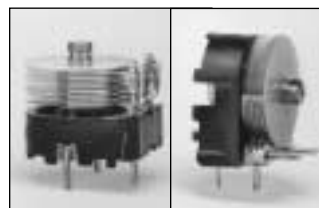
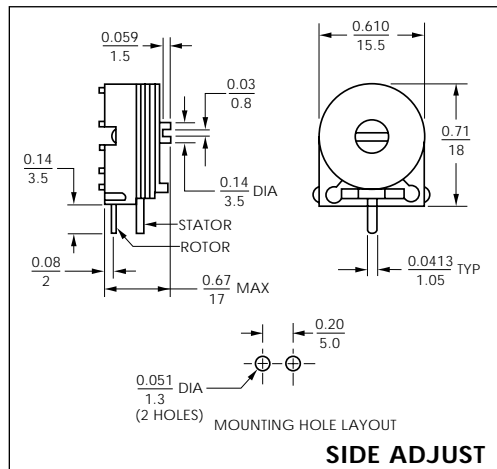

Dielectric	Capacitance (pF)		Q min (1MHz)	TCC (ppm/°C)	Operating Temperature (°C)	Color Code	Top Adjust	Side Adjust
	min	max					Model Number	Model Number
PC	9.0	200.0	200	0 ± 300	-40 to +85	Orange	GZN20100	GZP20100
	18.0	300.0	200	0 ± 300	-40 to +85	Clear	GZN30100	GZP30100
PI	25.0	600.0	150	0 ± 350	-40 to +85	None	GZN60100	GZP60100

All dimensions are in / mm.



PART NUMBERING SYSTEM

<u>GX</u>		<u>A</u>		<u>9R0</u>	<u>00</u>	
Dielectric		Form Factor		Cap Code	Modifications (Top Adjust Models)	
Symbol	Description	Symbol	Description	Industry Standard, i.e.	Symbol	Description
GC	PPS (Polyphenyl Sulfide)	A	8 mm Top/Bottom Adjust	1R6 = 1.6 pF,	01	6 x 8 mm, 2 leads, GXE and GXQ series only
GSX**	PTFE (Polytetrafluor- oethylene)	B	8 mm Side Adjust	400 = 40.0 pF,	02	8 mm, 2 leads
		C	10 mm Top/Bottom Adjust, 11 x 13 mm Top/Bottom Adjust	301 = 300.0 pF	03	10 mm, 3 lead, special
GX	PTFE (Polytetrafluor- oethylene)	D	10 mm Side Adjust		04	10 mm, 2 leads
GY	PP (Polypropylene)	E*	6 x 8 mm Top/Bottom Adjust, 8 mm Top/Bottom Adjust		11	6 x 8 mm, 3 leads
GZ	PC or PI (Polycarbonate or Polyimide)	F*	10 mm Top/Bottom Adjust		12	11 x 13 mm, housing protected (available on all 10 mm top and bottom adjust units)
		L	5 mm Top Adjust, 7 mm Economy		25	Ammo pack version for GCL only
		N	16 mm Top Adjust			
		P	16 mm Side Adjust			
		Q*	6 x 8 mm Side Adjust			
		R*	8 mm Side Adjust			
		T*	10 mm Side Adjust			

* Extended temperature range: -40°C to +125°C

** GSX parts do not conform to part numbering system above.

For other modifications such as high temperature base material or special lead plating, contact factory.

SPECIFICATION NOTES

- Parts are 100% tested for capacitance range and dielectric withstanding voltage.
- Capacitance range specified is that which is guaranteed, and is measured at 1 MHz at room temperature.
- Q factor is measured at maximum rated capacitance and at room temperature.
- Dielectric strength is measured at maximum rated capacitance and room temperature, with test voltage (as listed for each model) applied for 60 seconds.
- Insulation resistance is measured at maximum rated capacitance and room temperature and at rated voltage, unless otherwise specified.
- Temperature coefficient of capacitance (TCC) is measured at 1 MHz over the operating temperature range, with capacitor set at maximum rated capacitance.
- Axial load during tuning should not exceed 200 grams force. At maximum axial load, capacitance change is no more than 15%.
- Capacitors should not be operated outside of rated capacitance range and working voltage.

Soldering and Cleaning

of FILMTRIM® Trimmer Capacitors

Soldering Methods

- Reflow soldering for GSX series
Pre-heat: 140°C ±10°C for 2 to 3 minutes.
Soldering: 200 to 250°C within 25 seconds.
(Peak soldering temperature: 250°C maximum).
- Dip soldering (does not apply to GSX models)
260°C ±10°C for 7 seconds maximum.
- Hand soldering (for lead-through-hole models)
Soldering: Tip temperature 350°C ±10°C for 3 to 4 seconds
- Hand soldering (GSX models)
Preheating: Fully preheat on a hot plate with a surface temperature of 100 to 150°C.
Soldering: 260°C ±10°C for 5 seconds maximum.

Cleaning

- Water soluble fluxes and detergents with a water flush after soldering of the boards can be used for GX, GY and GZ models.
- Do not immerse FILMTRIM models in chlorinated or fluorinated hydrocarbon solvents as this would adversely affect the plastic dielectrics and base materials. Some customers have successfully used GX models in scrubbers or sprayers where only the bottom of the printed circuit boards is exposed to solvents. If the process requires immersion in solvents for cleaning boards, the FILMTRIM capacitors should be hand soldered to board after the boards have been cleaned.