

阅读申明

- 1.本站收集的数据手册和产品资料都来自互联网，版权归原作者所有。如读者和版权方有任何异议请及时告之，我们将妥善解决。
- 2.本站提供的中文数据手册是英文数据手册的中文翻译，其目的是协助用户阅读，该译文无法自动跟随原稿更新，同时也可能存在翻译上的不当。建议读者以英文原稿为参考以便获得更精准的信息。
- 3.本站提供的产品资料，来自厂商的技术支持或者使用者的心得体会等，其内容可能存在描述上的差异，建议读者做出适当判断。
- 4.如需与我们联系，请发邮件到marketing@iczoom.com，主题请标有“数据手册”字样。

Read Statement

1. The datasheets and other product information on the site are all from network reference or other public materials, and the copyright belongs to the original author and original published source. If readers and copyright owners have any objections, please contact us and we will deal with it in a timely manner.
2. The Chinese datasheets provided on the website is a Chinese translation of the English datasheets. Its purpose is for reader's learning exchange only and do not involve commercial purposes. The translation cannot be automatically updated with the original manuscript, and there may also be improper translations. Readers are advised to use the English manuscript as a reference for more accurate information.
3. All product information provided on the website refer to solutions from manufacturers' technical support or users the contents may have differences in description, and readers are advised to take the original article as the standard.
4. If you have any questions, please contact us at marketing@iczoom.com and mark the subject with "Datasheets" .

PRODUCT NO. NOTE 8	DIM "A"	DIM "B"	MATERIAL	DIM "C"*	SHEET NO.	APPLICATION NOTES
77031-102 77031-102LF	.37/9.5	.585/14.86	STAINLESS STEEL AISI 430 or 416	.320/8.13	SEE SHT. 2	3
77031-103 77031-103LF	.50/12.7	.585/14.86		.320/8.13	SEE SHT. 3	4
77031-106 77031-106LF	.43/10.9	.585/14.86		.320/8.13	SEE SHT. 4	5
77031-113 77031-113LF	.75/19.1	.585/14.86		.320/8.13	SEE SHT. 5	6 AND 7

* MINIMUM THREAD LENGTH

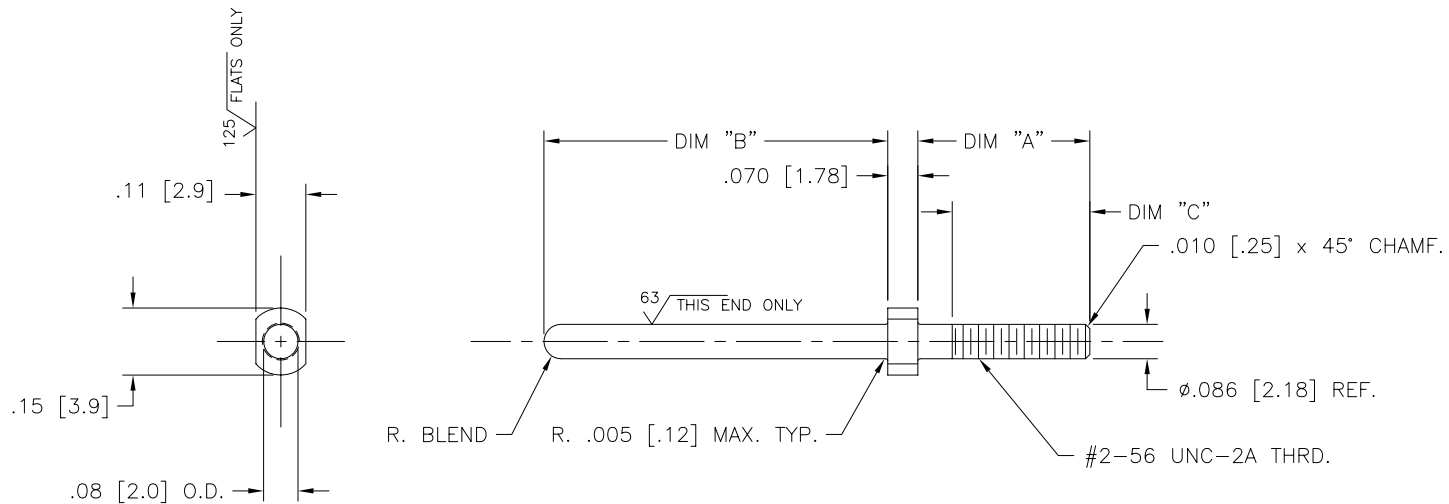

NOTES:

1. MECHANICAL GUIDANCE ONLY.
2. GUIDE PIN IS .027 [.68] LONGER THAN WHAT IS REQUIRED TO ALIGN CONNECTORS WHEN HOUSING FACES ARE .035 [.88] APART.
3. SHROUD CAN'T BE USED WITH THIS GUIDE PIN.
4. GUIDE PIN MAY BE USED WITH A SHROUD OR SCREWED TO A .187 [4.74] PCB.
5. GUIDE PIN MAY BE USED WITH...
... SHROUD AND .125 [3.17] PCB.
... NUT, WASHER, AND .125 [3.17] PCB.
6. GUIDE PIN MAY USE SHROUD OR SCREW.
APPLICATION MAY USE MOUNTING FRAME.
7. MAXIMUM STACK IS .480 [12.20].
8. ADD AN LF SUFFIX TO PART NUMBERS FOR PRODUCT THAT MEETS EUROPEAN UNION DIRECTIVES AND OTHER COUNTRY REGULATIONS AS DESCRIBED IN GS-22-008.
9. THIS PRODUCT IS NOT INTENDED TO BE EXPOSED TO MANUFACTURING SOLDER PROCESSES.

mat'l. code SEE TABLE		surface ISO 1302 ✓		tolerance ISO 406 ISO 1101		projection INCH/MM		product family HPC	
ltr	ecm no	dr	date	tolerances unless otherwise specified		INCH/MM		title CENTER GUIDE PIN	
D	V20385	MRC	3/27/92	angles	.XX±.01/.3		scale 1:1		
E	V32128	GIP	11/18/93	linear	.xxx±.005/.13		dwg no 77031		
F	v00717	LSS	3/22/00	0'±2'	.xxx±.0020/.05		sheet 1 of 5 size A3		
G	v05-0964	HTB	10/18/05	dr	LSANDERS	3/22/00	type Product Customer Drawing		
H	M06-0260	MHT	7/07/06	enr	M.GRAY	3/22/00			
				chr	M.GRAY	3/22/00			
				appd	M.GRAY	3/22/00			
sheet index	revision sheet	H	H	H	H	H			
		1	2	3	4	5			

PRODUCT NO.
77031-102

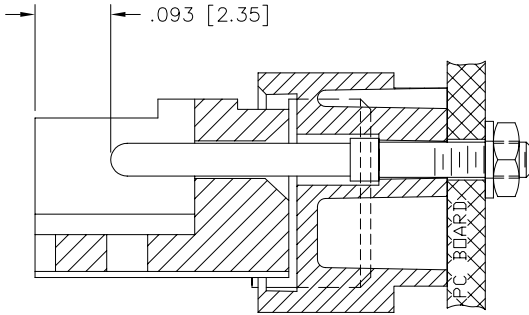
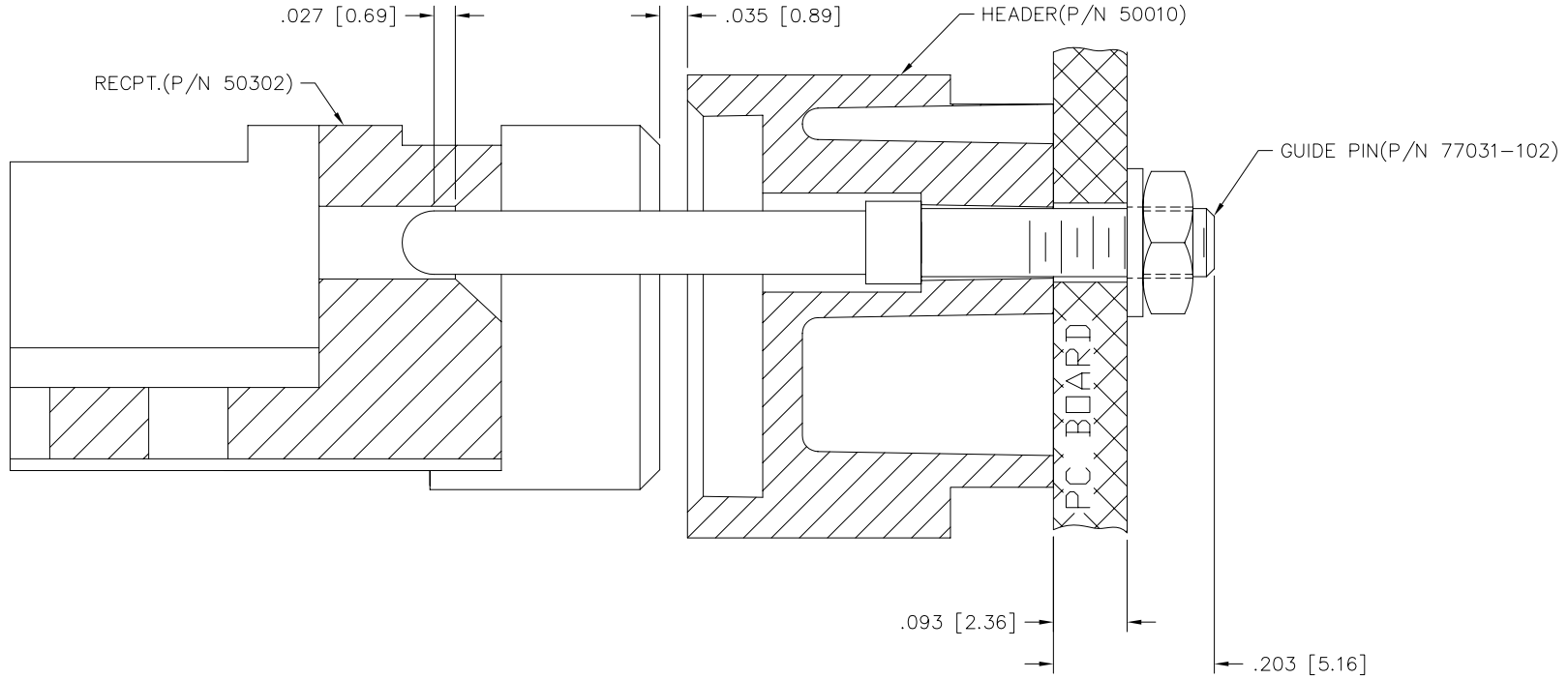

HOUSINGS FULLY MATED
(SCALE 20:1)

mat'l. code SEE TABLE		surface ISO 1302 ✓	tolerance ISO 406 ISO 1101	projection ⊕	product family HPC
ltr	ecn	no	dr	date	tolerances unless otherwise specified
H					angles linear 0°±2'
					.XX±.01/.3 .XXX±.005/.13 .XXX±.0020/.051
					dr LSANDERS 3/22/00 enr M.GRAY 3/22/00 chr M.GRAY 3/22/00 appd M.GRAY 3/22/00
sheet	revision				
index	sheet				
				scale 1:1	title CENTER GUIDE PIN
				dwg no 77031	sheet 2 of 5 size A3
				type Product Customer Drawing	

FCJ
FCJconnect.com
Copyright FCJ

PRODUCT NO
77031-103

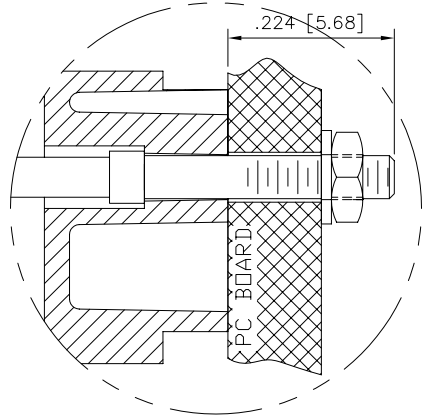
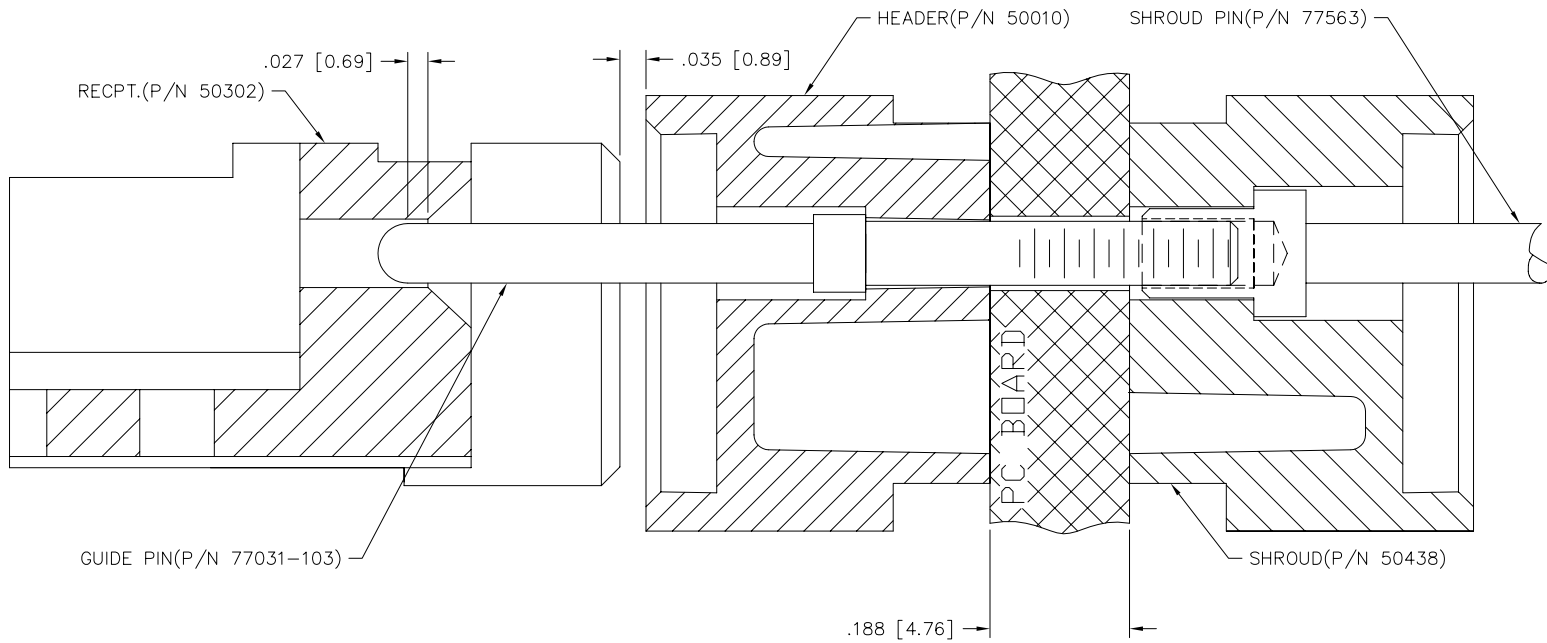

BOARD MOUNTED OPTION
(SCALE 30:1)

mat'l. code SEE TABLE		surface ISO 1302 ✓	tolerance ISO 406 ISO 1101	projection ⊕	product family HPC
ltr	ecr	no	dr	date	tolerances unless otherwise specified
H					angles linear 0°±2'
					.xx±.01/.3 .xxx±.005/.13 .xxx±.0020/.05
					dr LSANDERS 3/22/00 enr M.GRAY 3/22/00 chr M.GRAY 3/22/00 appd M.GRAY 3/22/00
sheet	revision				scale 1:1
index	sheet				FCJ
					title CENTER GUIDE PIN
					dwg no 77031 sheet 3 of 5 size A3
					type Product Customer Drawing

FCJ
FCIconnect.com
Copyright FCI

PRODUCT NO
77031-106

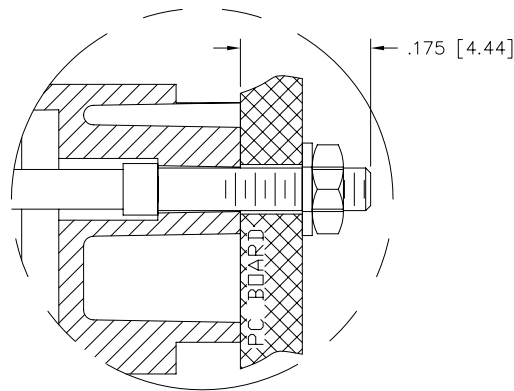
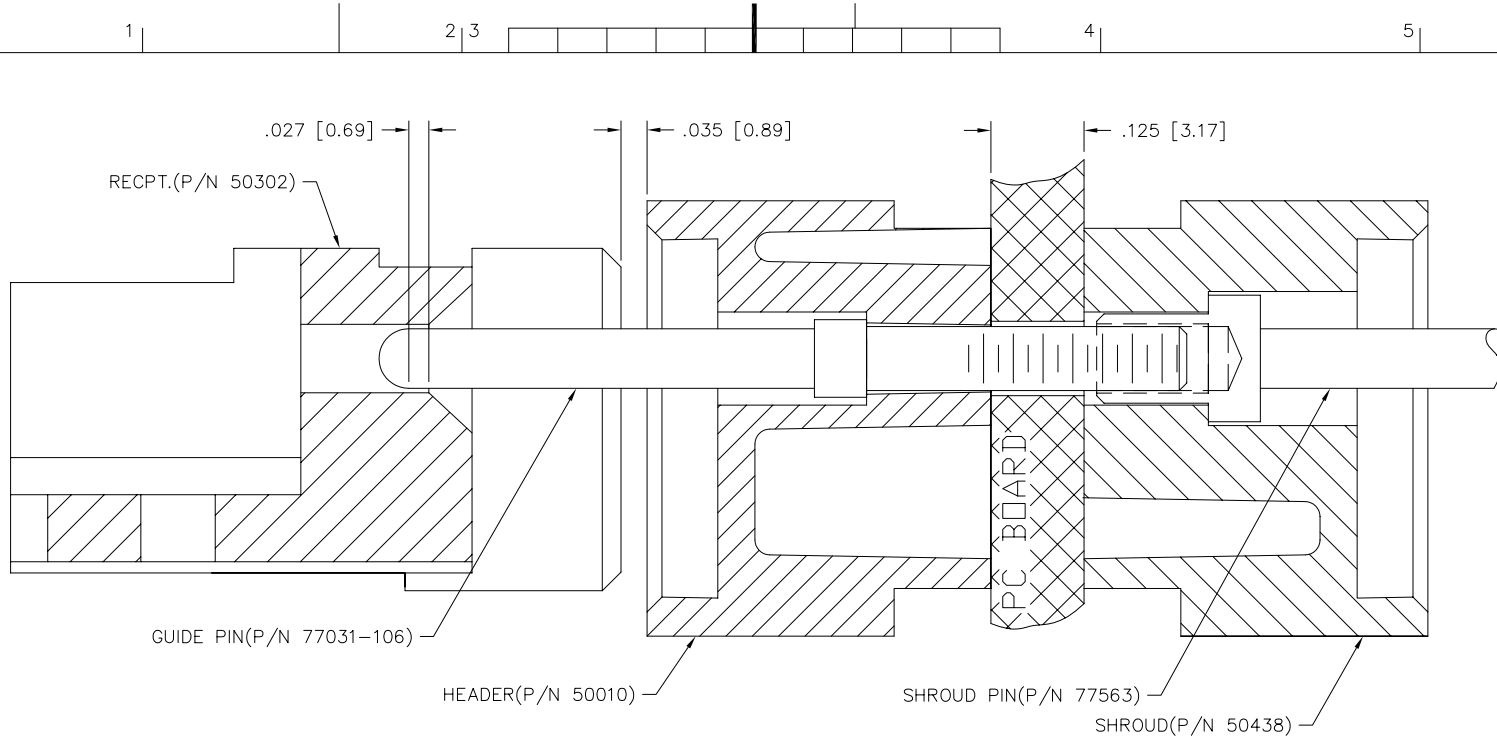

SCREW MOUNTED OPTION
(SCALE 30:1)

mat'l. code SEE TABLE		surface ISO 1302 ✓	tolerance ISO 406 ISO 1101	projection ⊕	product family HPC
ltr	ecn no	dr	date	tolerances unless otherwise specified	title
H				angles linear .XX±.01/.3 .xxx±.005/.13 .xxxx±.0020/.051	INCH/MM
				0°±2'	scale 1:1
		dr	LSANDERS	3/22/00	
		enr	M.GRAY	3/22/00	
		chr	M.GRAY	3/22/00	
		appd	M.GRAY	3/22/00	
sheet index	revision sheet				dwg no 77031 sheet 4 of 5 size A3 type Product Customer Drawing

Copyright FCI
 FCJ
 FCIconnect.com

PRODUCT NO
77031-113

GUIDE PIN(P/N 77031-113)

HEADER(P/N 50010)

RECPT.(P/N 50302)

.027 [0.69]

.035 [0.89]

.583 [14.81]
MAX. STACK

PC BOARD

MOUNTING
FRAME



FCIconnect.com

Copyright FCI

mat'l. code SEE TABLE		surface ISO 1302 ✓	tolerance ISO 406 ISO 1101	projection 	product family HPC
ltr	ecn no	dr	date	tolerances unless otherwise specified	title
H				angles linear 0°±2'	CENTER GUIDE PIN
				.XX±.01/.3 .XXX±.005/.13 .XXXX±.0020/.05	INCH/MM
				dr LSANDERS 3/22/00 enr M.GRAY 3/22/00 chr M.GRAY 3/22/00 appd M.GRAY 3/22/00	scale 1:1
sheet	revision				FCI
index	sheet				dwg no 77031 sheet 5 of 5 size A3
					type Product Customer Drawing

form: A3