

阅读申明

- 1.本站收集的数据手册和产品资料都来自互联网，版权归原作者所有。如读者和版权方有任何异议请及时告之，我们将妥善解决。
- 2.本站提供的中文数据手册是英文数据手册的中文翻译，其目的是协助用户阅读，该译文无法自动跟随原稿更新，同时也可能存在翻译上的不当。建议读者以英文原稿为参考以便获得更精准的信息。
- 3.本站提供的产品资料，来自厂商的技术支持或者使用者的心得体会等，其内容可能存在描述上的差异，建议读者做出适当判断。
- 4.如需与我们联系，请发邮件到marketing@iczoom.com，主题请标有“数据手册”字样。

Read Statement

1. The datasheets and other product information on the site are all from network reference or other public materials, and the copyright belongs to the original author and original published source. If readers and copyright owners have any objections, please contact us and we will deal with it in a timely manner.
2. The Chinese datasheets provided on the website is a Chinese translation of the English datasheets. Its purpose is for reader's learning exchange only and do not involve commercial purposes. The translation cannot be automatically updated with the original manuscript, and there may also be improper translations. Readers are advised to use the English manuscript as a reference for more accurate information.
3. All product information provided on the website refer to solutions from manufacturers' technical support or users the contents may have differences in description, and readers are advised to take the original article as the standard.
4. If you have any questions, please contact us at marketing@iczoom.com and mark the subject with "Datasheets" .

2mm Hard Metric Connector

PCN21 Series

IEC 61076-4-101-compliant

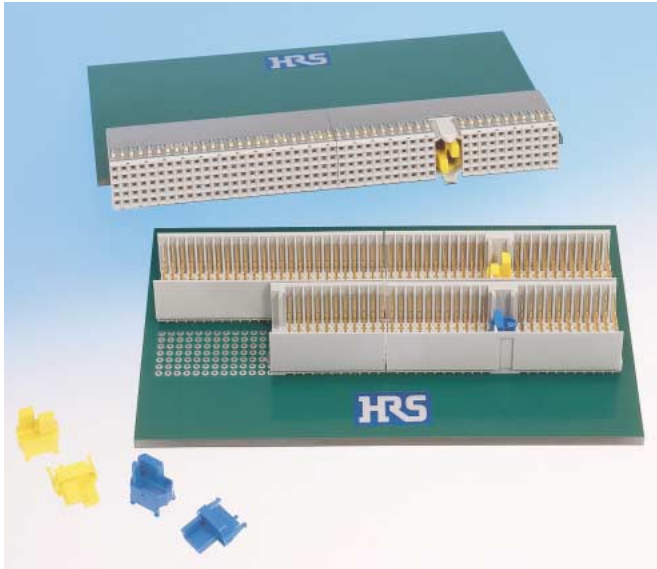

Applications

Switchboards, transmission systems, Cellular base stations, industrial computer boards, measuring instruments, control equipment

Product varieties (see page 2 for details)

Features

1. IEC compliant

This 2 mm Hard Metric (HM) Connector complies with IEC 61076-4-101. As specified by IEC Standards, 3 types are available: Style A (110 contacts), Style B (125 contacts), Style C (55 contacts) and Style M.

2. Many Variations

Products equivalent to Compact PCI standard P2/J2 (110 contacts), P3/J3 (95 contacts) and AB Type (125 contacts) are available.

3. Press-fit connection

Connectors of this series, headers and receptacles, are designed for press fit connection.

4. Both-side, two-point contact

Receptacles feature two-point contact design for high reliability.

5. Ground Connection Supported

Contacts are lined up in rows z a b c d e f. Five rows (a b c d e) are used for signals and two rows (z f) can be added at both sides for use as ground.

6. 3-Stage Sequence Supported

There are 3 types of coupling portion contact lengths for the header which permits a 3-stage sequence.

7. Coding Keys Can Be Mounted

Coding keys can be attached to style A for the purpose of preventing incorrect insertion of the connector.

8. Two different platings are available on PCB leads

Gold plating and Tin plating are available on PCB leads.

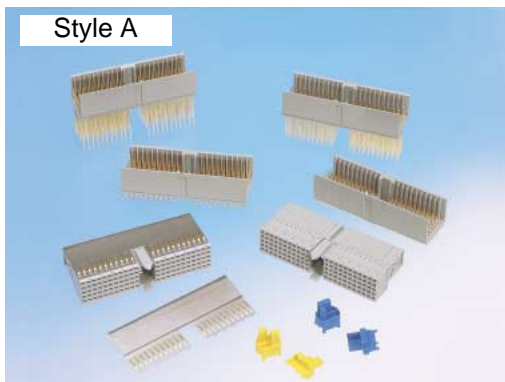

Style A

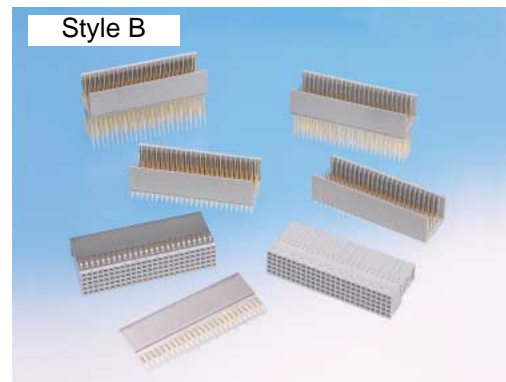

Style B

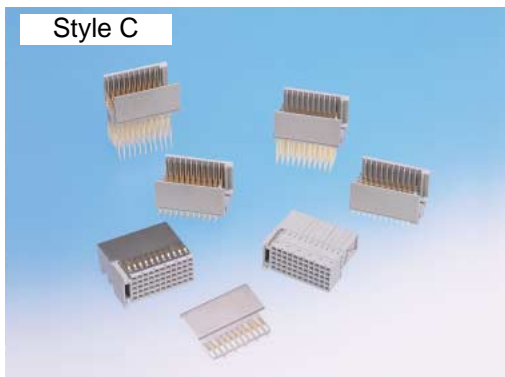

Style C



Compact PCI P2/J2, P3/J3 equivalent

PCN21 Series Selection Chart

Standards		IEC 61076-4-101 compliant			Compact PCI P2/J2 equivalent	Compact PCI P3/J3 equivalent		
		Style A	Style B	Style C				
Item								
		Header connector (Back Wiring Board side (BWB) male connector)	Short pin type	Without ground terminal	 PCN21*-110PA-2PF	 PCN21*-125PB-2PF	 PCN21*-55PC-2PF	 PCN21*-110PB-2PF
With ground terminal	 PCN21*-110PA-2PF-G			 PCN21*-125PB-2PF-G	 PCN21*-55PC-2PF-G	 PCN21*-110PB-2PF-G	 PCN21*-95PB-2PF-G	
Long pin type	Without ground terminal		 PCN21*-110PA-2W	 PCN21*-125PB-2W	 PCN21*-55PC-2W	 PCN21*-110PB-2W	 PCN21*-95PB-2W	
	With ground terminal		 PCN21*-110PA-2W-G	 PCN21*-125PB-2W-G	 PCN21*-55PC-2W-G	 PCN21*-110PB-2W-G	 PCN21*-95PB-2W-G	
Receptacle connector (Package side female connector)	Without ground plate		 PCN21*-110SA-2PF	 PCN21*-125SB-2PF	 PCN21*-55SC-2PF	 PCN21*-110SB-2PF	 PCN21*-95SB-2PF	
	With ground plate		With top ground plate	 PCN21*-110SA-2PF-G	 PCN21*-125SB-2PF-G	 PCN21*-55SC-2PF-G	 PCN21*-110SB-2PF-G	 PCN21*-95SB-2PF-G
			Bottom ground plate	 PCN21*-SA-G	 PCN21*-SB-G	 PCN21*-SC-G	 PCN21*-SB1-G	 PCN21*-SB2-G

*A...PCB leads : Gold plating
B...PCB leads : Tin plating

Ordering information

Connector

PCN 2 1 * - * P A * - 2 PF - G (01)

① ② ③ ④ ⑤ ⑥ ⑦ ⑧ ⑨ ⑩

① Series name : PCN 21	⑥ Positioning peg (Applicable to receptacle styles A and C only) Nil : With peg A : Without peg
② A...PCB leads : Gold plating B...PCB leads : Tin plating	⑦ Contact pitch: 2 mm
③ No. of contacts : 55, 95, 110, 125	⑧ Terminal shape PF : Press-fit short pin W : Press-fit back plane
④ Connector classification P: Pin header S: Receptacle	⑨ Ground Nil : Without ground terminal G : With ground terminal
⑤ IEC type A : IEC 61076-4-101 Style A B : IEC 61076-4-101 Style B C : IEC 61076-4-101 Style C M : IEC 61076-4-101 Style M AB : Compact PCI AB type equivalent (For Compact PCI P2/J2, P3/J3 equivalent, the IEC type should be style B.)	⑩ Contact area gold plating thickness Nil : 0.8 μm (01) : 0.2 μm

Bottom ground plate for receptacle

PCN 2 1 * - S A - G

① ② ③ ④ ⑤

① Series name: PCN21	④ Applicable connectors A : for PCN21*-110SA-2PF-G B : for PCN21*-125SB-2PF-G C : for PCN21*-55SC-2PF-G B1: for PCN21*-110SB-2PF-G B2: for PCN21*- 95SB-2PF-G
② A...PCB leads : Gold plating B...PCB leads : Tin plating	
③ Connector classification: for receptacle use	⑤ Ground

Product construction

Header

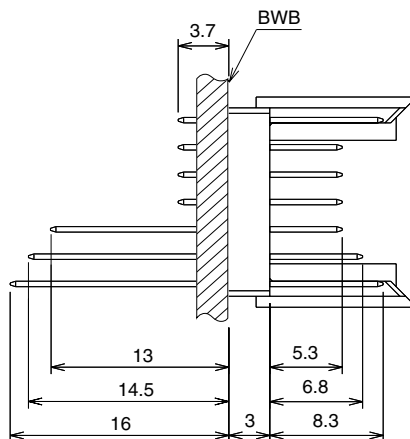

Receptacle

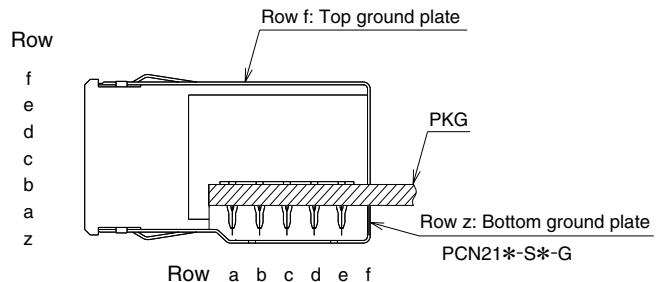

A ground plate is joined with the f row.

Rows f and z are ground terminals.
PCN21*-*P*-2PF (W) has no ground terminal
PCN21*-*P*-2PF (W)-G has ground terminal

PCN21*-*S*-2PF has no top ground plate
PCN21*-*S*-2PF-G has top ground plate
PCN21*-S*-G has bottom ground plate only

■Product Specifications

Rating	Current rating	1.5A	Operating temperature	-55°C to +85°C	Storage temperature	-10°C to +60°C
	Voltage rating	AC 300V	Operating humidity	95% RH max. (No condensation)	Storage humidity	40% to 70% RH

Item	Requirements	Test Conditions
1.Insulation resistance	10 ⁴ M ohms	100 V DC
2.Withstanding voltage	No flashover or breakdown	750 V rms AC for 1 min
3.Contact resistance	30 m ohms max.	0.1 A
4.Vibration	No electrical discontinuity for 1μs min.	Frequency 10 to 500 Hz, amplitude of 0.35 mm in 3 directions, 50m/s ² acceleration, 10 cycles each
5.Damp heat	Contact resistance: 40 m ohms max. Insulation resistance: 10 ³ M ohms min.	40 ±2°C, 90 to 95% RH, duration 96 h
6.Rapid change of temperature	Contact resistance:40 m ohms max. Insulation resistance: 10 ³ M ohms min. No damage, cracks or parts looseness	5 cycles (-55°C for 30 min, 15 to 30°C for 5 min max, +125°C for 30 min, 15 to 30°C for 5 min max.)
7.Heat resistance	Contact resistance:40 m ohms max. Insulation resistance: 10 ³ M ohms min.	Ambient temperature + 125°C, 16 h
8.Operation life	Contact resistance:40 m ohms max.	500 cycles

■Materials

Product	Part	Material	Finish	Remarks
Header	Insulator	PBT	Gray	UL94V-0
	Terminal	Phosphor bronze	PCN21A Contact area: Nickel base, gold plating PCB leads : Nickel base, gold plating PCN21B Contact area: Nickel base, gold plating PCB leads : Nickel base, tin plating	—
Receptacle	Insulator	PBT	Gray	UL94V-0
	Terminal	Phosphor bronze	PCN21A Contact area: Nickel base, gold plating PCB leads : Nickel base, gold plating PCN21B Contact area: Nickel base, gold plating PCB leads : Nickel base, tin plating	—
	Shield	Phosphor bronze	PCN21A Contact area: Nickel base, gold plating Mounted area: Nickel base, solder plating PCN21B Contact area: Nickel base, gold plating PCB leads : Nickel base, tin plating	—

Header (Style A) [BWB-side male connector]

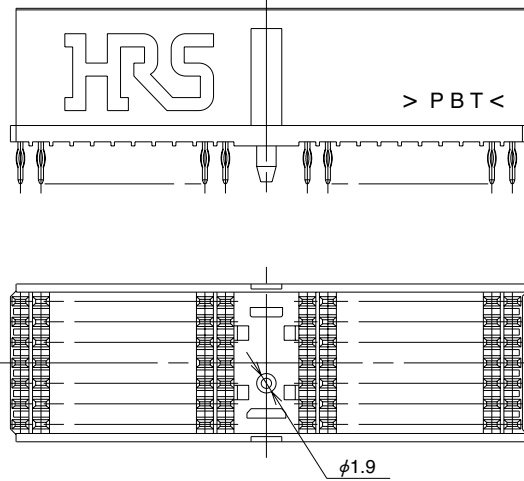
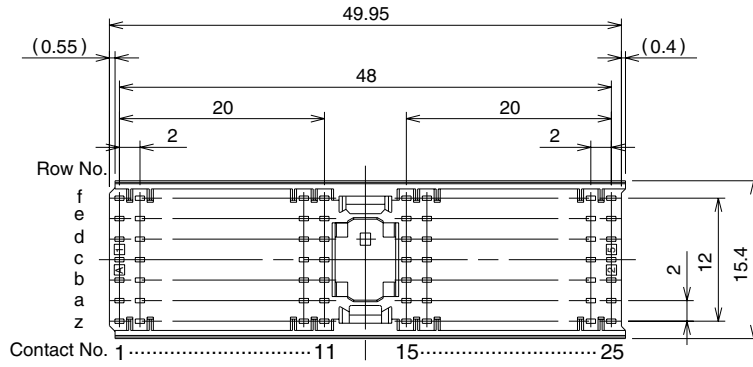

< Short pin > < Long pin >

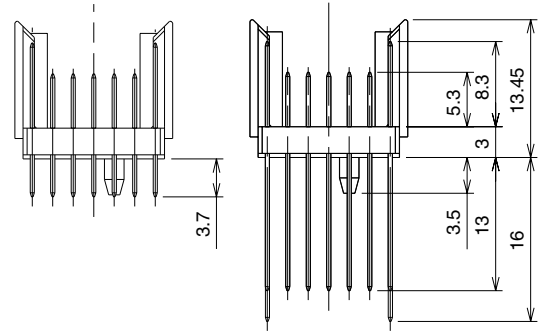

Recommended PCB mounting pattern

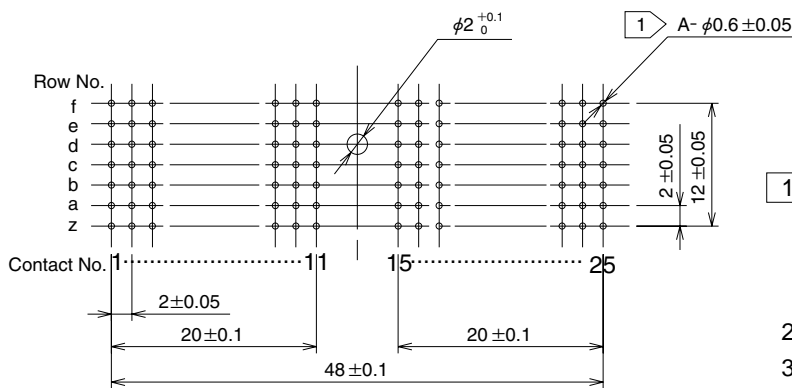

- 1 Through hole
 Drilling diameter : $\phi 0.7 \pm 0.02$
 Finishing diameter : $\phi 0.6 \pm 0.05$
 Plating : Cu 25 μ min.
- 2 For 5-row type, row f and z are unnecessary.
- 3 Board thickness : 1.6 to 5.6 mm

Product No.	A	No. of contacts	Mounted area
PCN21*-110PA-2PF	110	5	Short pin
PCN21*-110PA-2PF-G	154	7	
PCN21*-110PA-2W	110	5	Long pin
PCN21*-110PA-2W-G	154	7	

*A...PCB leads : Gold plating
 B...PCB leads : Tin plating

Header (Style B) [BWB-side male connector]

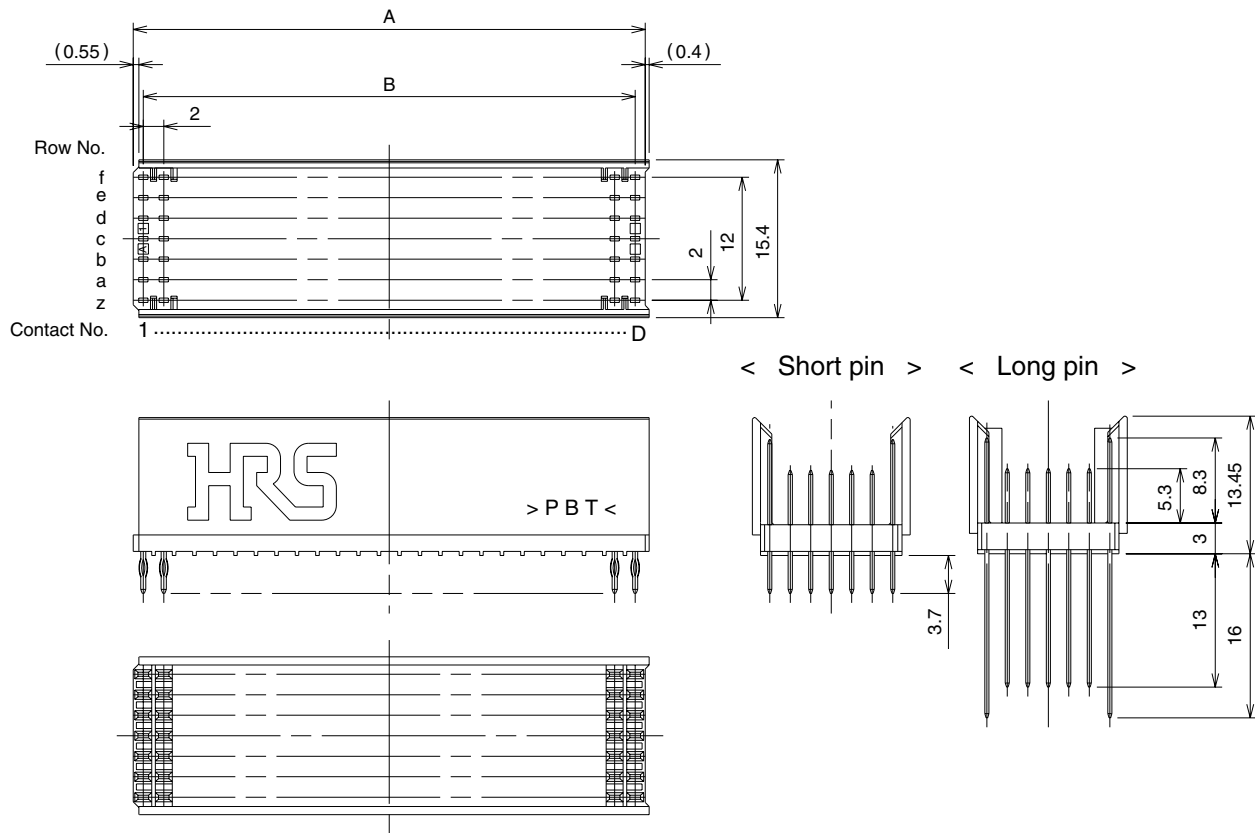

Recommended PCB Footprints mounting pattern

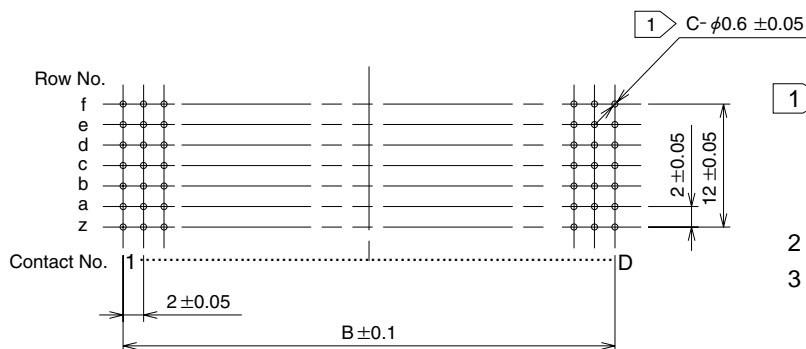

- 1 Through hole
 Drilling diameter : $\phi 0.7 \pm 0.02$
 Finishing diameter : $\phi 0.6 \pm 0.05$
 Plating : Cu 25 μ min.
- 2 For 5-row type, row f and z are unnecessary.
- 3 Board thickness : 1.6 to 5.6 mm

Product No.	A	B	C	D	No. of contacts	Mounted area
PCN21*-125PB-2PF	49.95	48	125	25	5	Short pin
PCN21*-125PB-2PF-G	49.95	48	175	25	7	
PCN21*-110PB-2PF	49.95	42	110	22	5	
PCN21*-110PB-2PF-G	49.95	42	154	22	7	
PCN21*- 95PB-2PF	37.95	36	95	19	5	Long pin
PCN21*- 95PB-2PF-G	37.95	36	133	19	7	
PCN21*-125PB-2W	43.95	48	125	25	5	
PCN21*-125PB-2W-G	43.95	48	175	25	7	
PCN21*-110PB-2W	43.95	42	110	22	5	
PCN21*-110PB-2W-G	43.95	42	154	22	7	
PCN21*- 95PB-2W	37.95	36	95	19	5	
PCN21*- 95PB-2W-G	37.95	36	133	19	7	

*A...PCB leads : Gold plating
 B...PCB leads : Tin plating

Header (Style C) [BWB-side male connector]

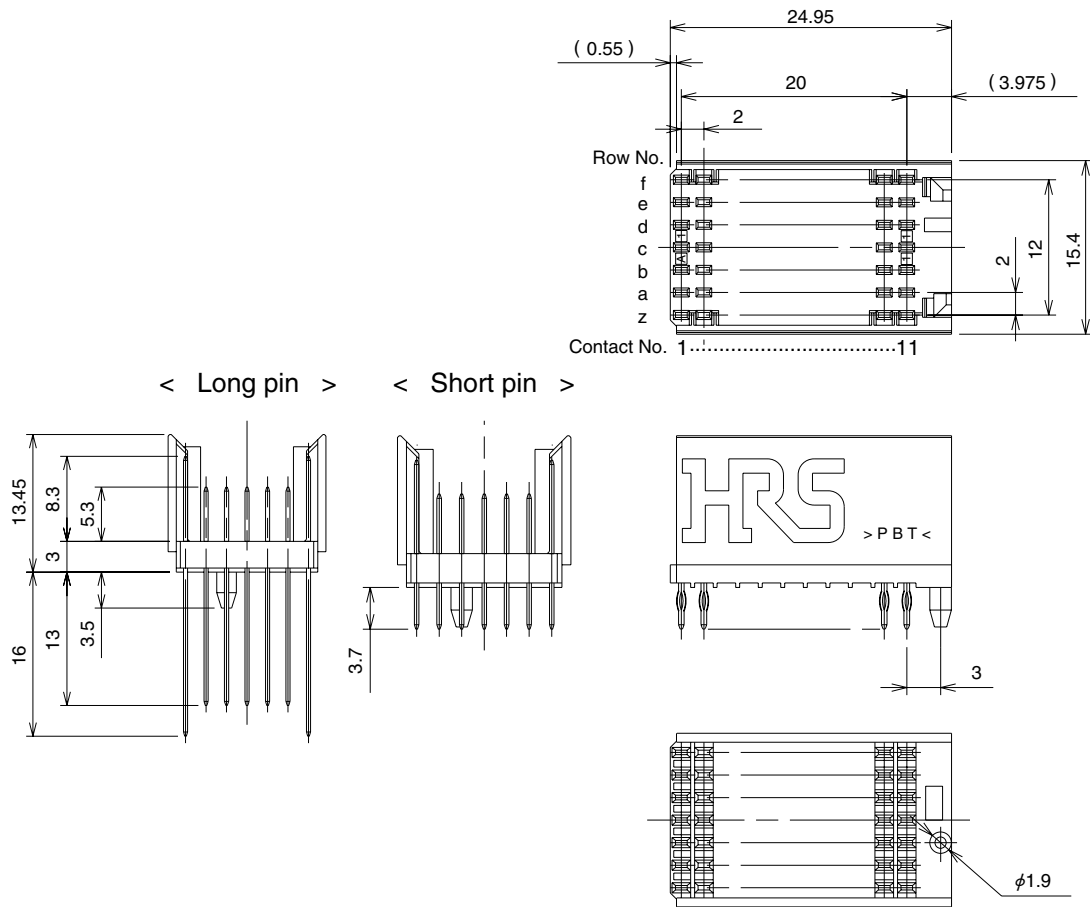

Recommended PCB mounting pattern

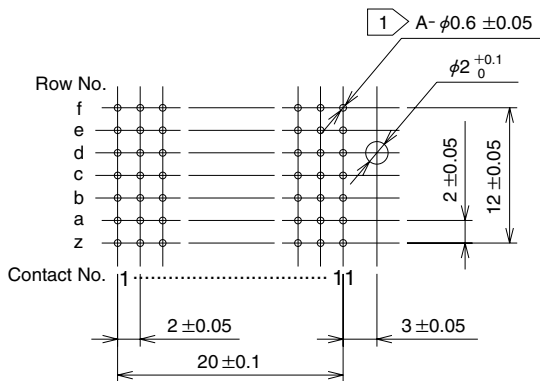

- 1 Through hole
 Drilling diameter : $\phi 0.7 \pm 0.02$
 Finishing diameter : $\phi 0.6 \pm 0.05$
 Plating : Cu 25 μ min.
- 2 For 5-row type, row f and z are unnecessary.
- 3 Board thickness : 1.6 to 5.6 mm

Product No.	A	No. of contacts	Mounted area
PCN21*-55PC-2PF	55	5	Short pin
PCN21*-55PC-2PF-G	77	7	
PCN21*-55PC-2W	55	5	Long pin
PCN21*-55PC-2W-G	77	7	

*A...PCB leads : Gold plating
 B...PCB leads : Tin plating

Header (Style M) [BWB-side male connector]

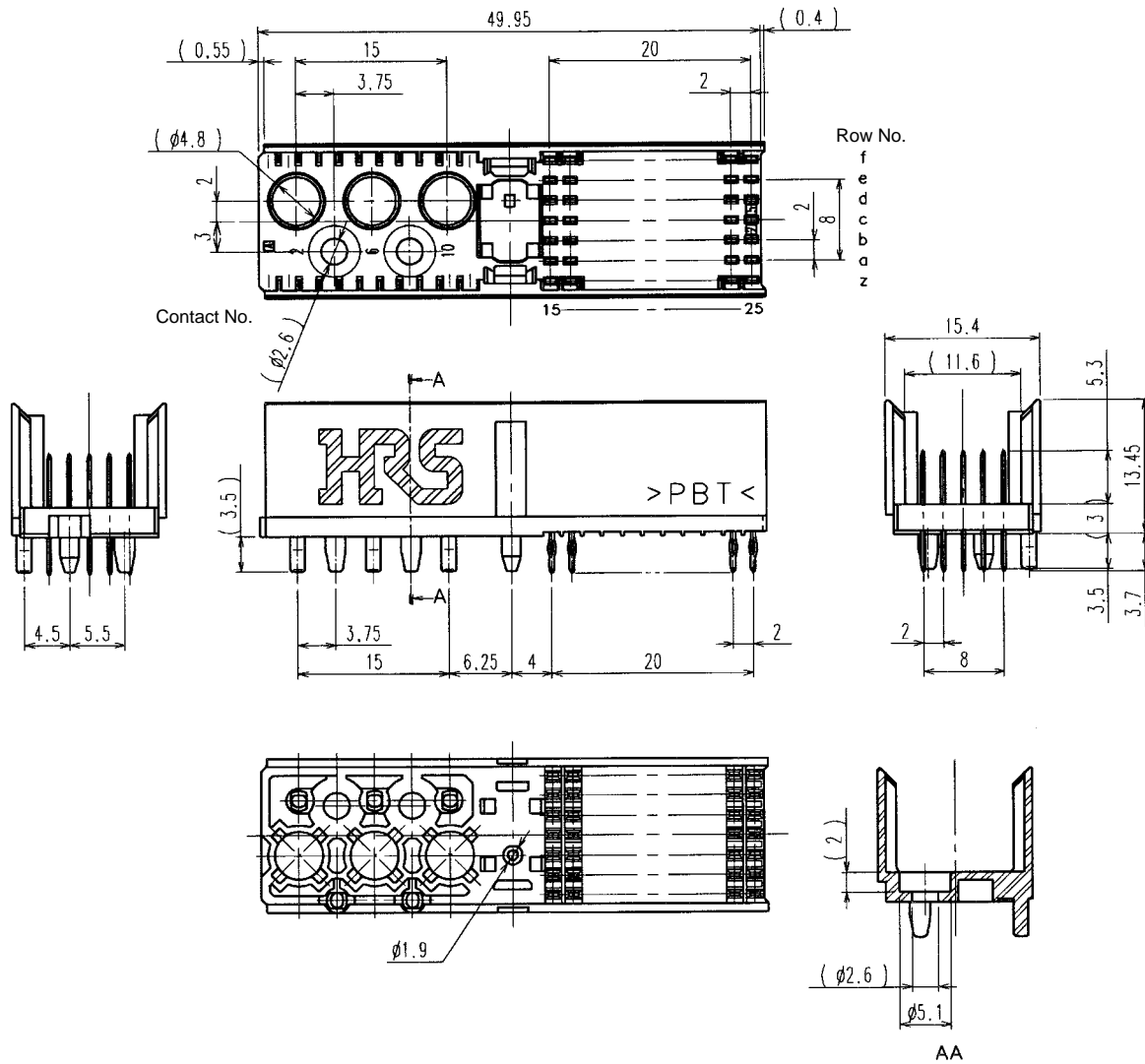

Recommended PCB mounting pattern

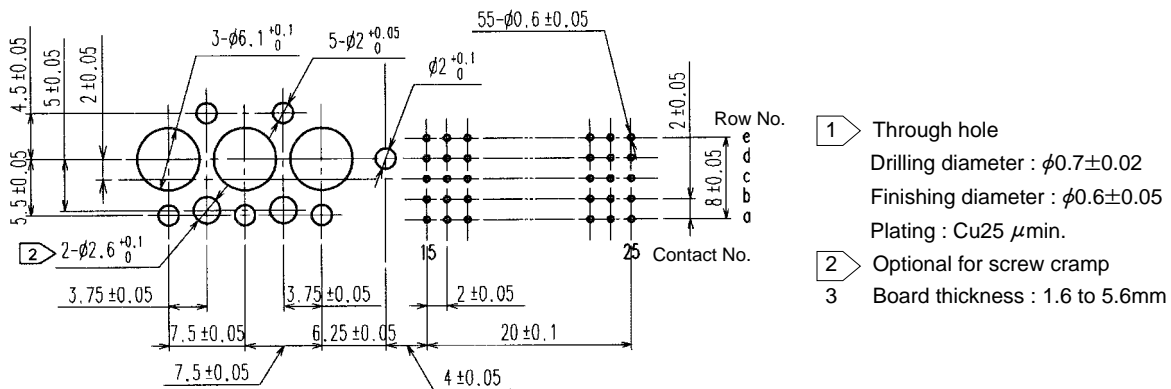

Product No.	No. of contacts	Mounted area
PCN21*-55PM-2PF	5	Short Pin

* A...PCB leads : Gold plating, B...PCB leads : Tin plating

Header (Style AB) [BWB-side male connector]

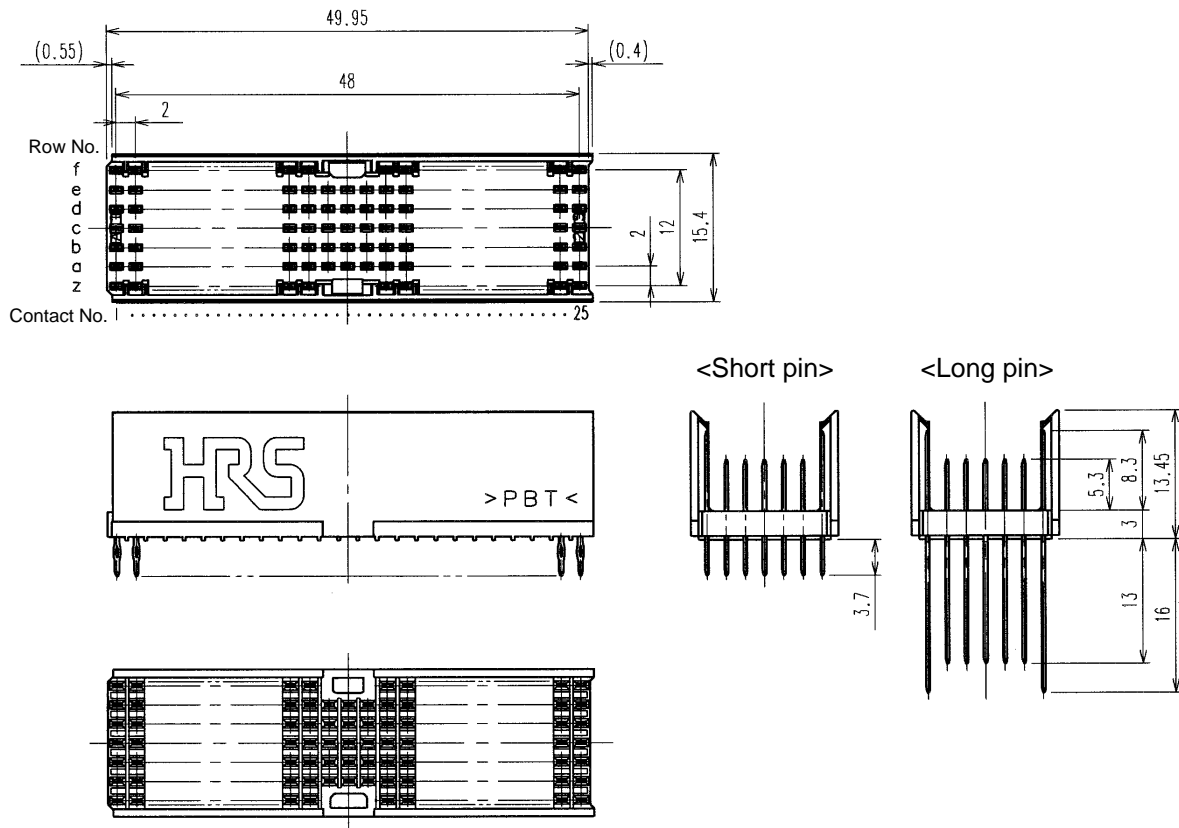

Recommended Mounting Hole Pattern

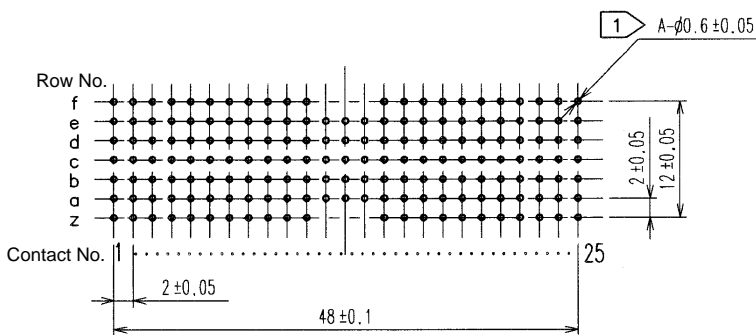

- 1 Through hole
Drilling diameter : $\phi 0.7 \pm 0.02$
Finishing diameter : $\phi 0.6 \pm 0.05$
Plating : $\text{Cu}25\mu\text{min}$.
- 2 For 5-row type, row f and z are unnecessary
- 3 Board thickness : 1.6 to 5.6mm

Product No.	A	No. of contacts	Mounted area
PCN21*-125PAB-2PF	125	5	Short Pin
PCN21*-125PAB-2PF-G	169	7	
PCN21*-125PAB-2W	125	5	Long Pin
PCN21*-125PAB-2W-G	169	7	

* A...PCB leads : Gold plating, B...PCB leads : Tin plating

■ Receptacle (Style A) [PKG-side female connector]

< With ground plate >

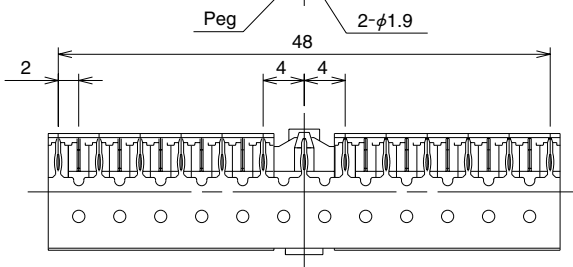
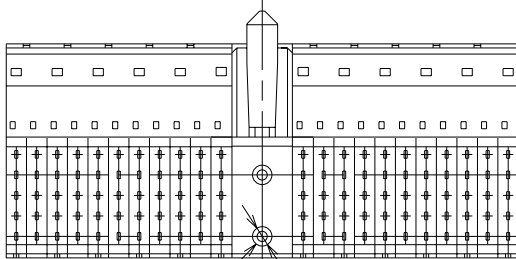
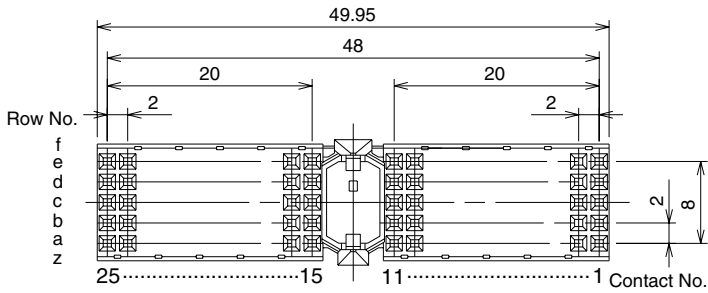
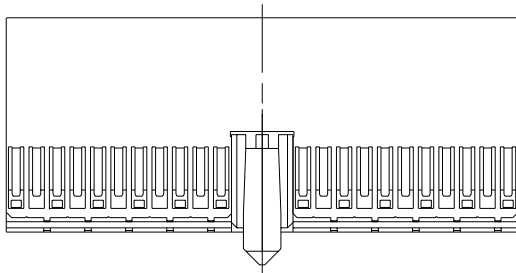

< Without ground plate >

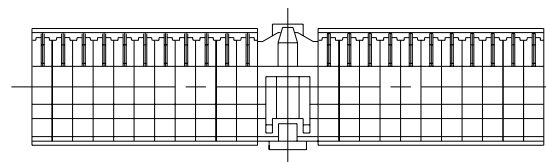
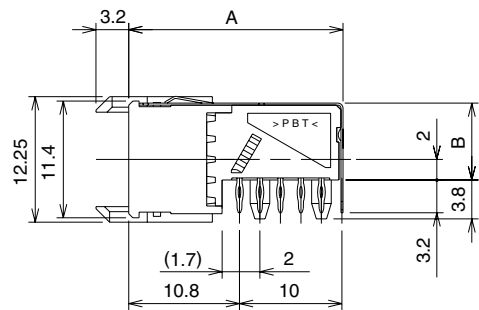
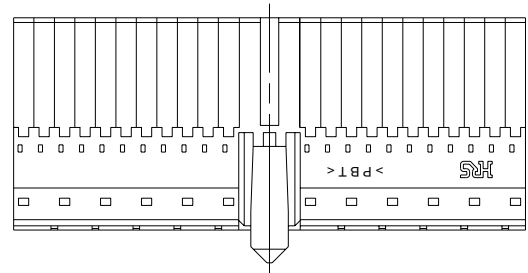

◆ Recommended PCB mounting pattern

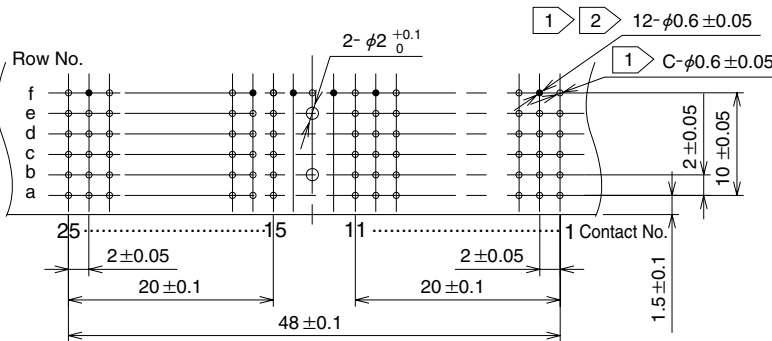

- 1 Through hole
Drilling diameter: $\phi 0.7 \pm 0.02$
Finishing diameter: $\phi 0.6 \pm 0.05$
Plating: Cu 25 μ m min.
- 2 Even numbers are required on the f row when using the lower surface ground plate (PCN21*, SA-G).
- 3 For without ground the plate type, rows f and z unnecessary.
- 4 The type without the peg does not require the 2mm dia. hole.
- 5 Board thickness: 1.6 to 4.2 mm

Product No.	A	B	C	Ground plate	Peg
PCN21*-110SA-2PF	20.7	7.3	110	Not provided	Provided
PCN21*-110SA-2PF-G	20.9	7.5	123	Provided	
PCN21*-110SAA-2PF	20.7	7.3	110	Not provided	Not provided
PCN21*-110SAA-2PF-G	20.9	7.5	123	Provided	

* A...PCB leads : Gold plating, B...PCB leads : Tin plating

■ Receptacle (Style B) [PKG-side female connector]

< With ground plate >

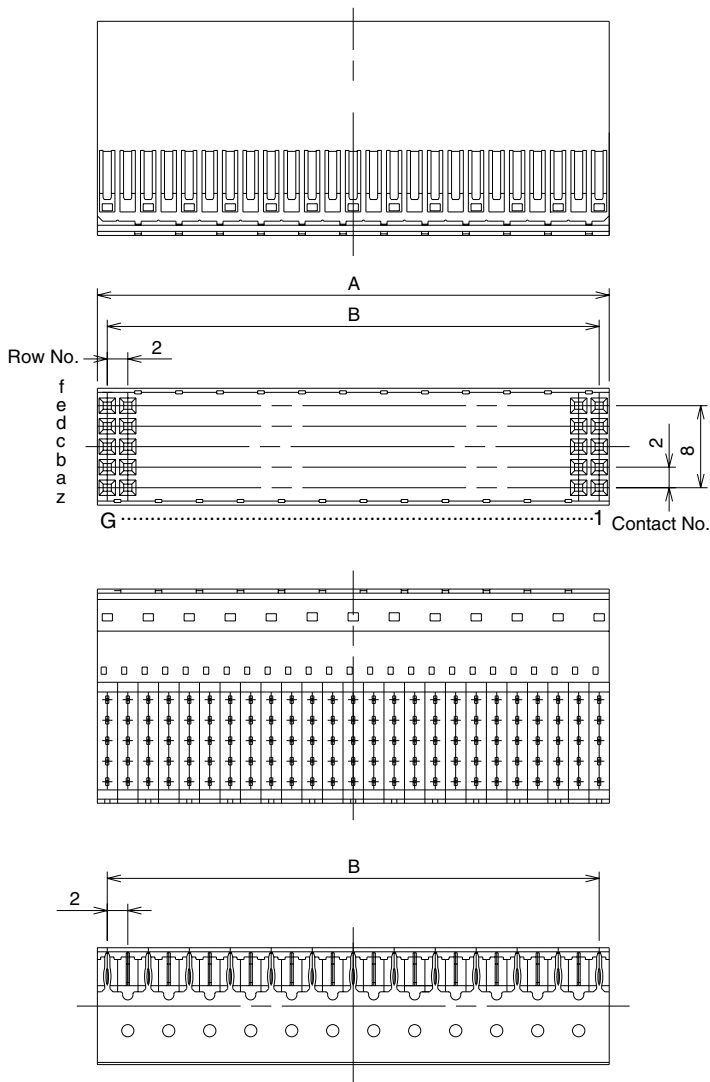

< Without ground plate >

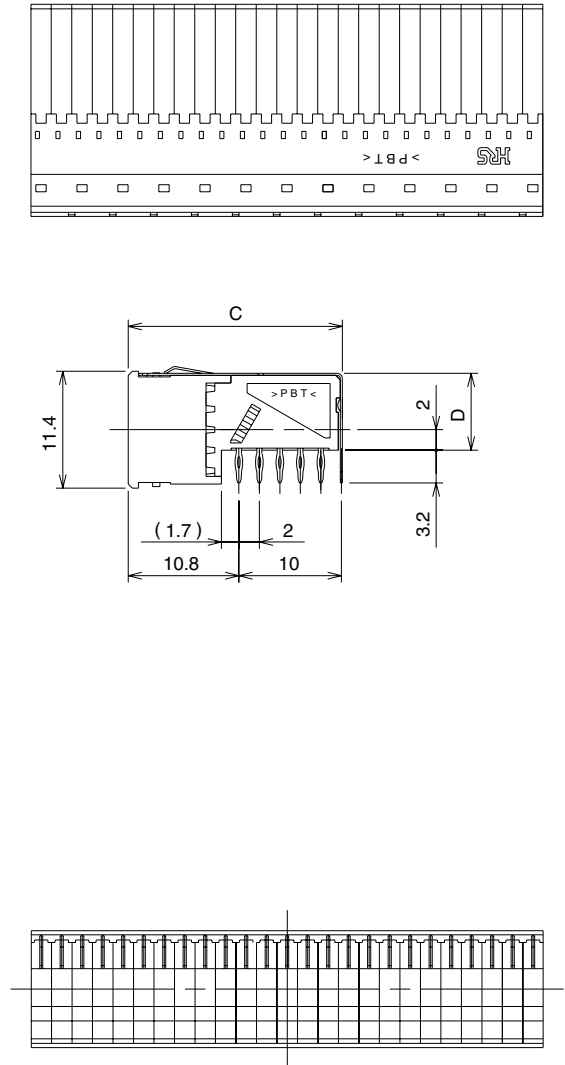

◆ Recommended PCB mounting pattern

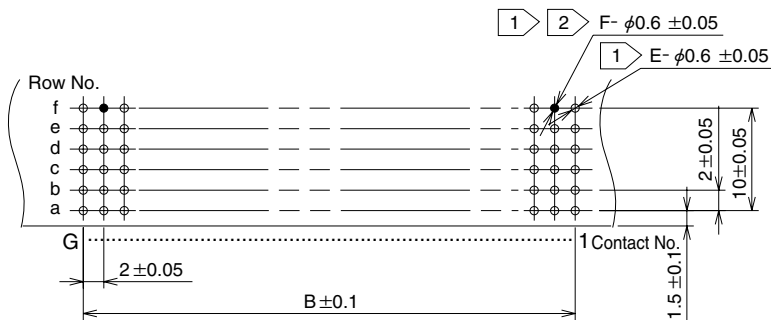

- 1 Through hole
Drilling diameter: $\phi 0.7 \pm 0.02$
Finishing diameter: $\phi 0.6 \pm 0.05$
Plating: Cu $25 \mu\text{m}$ min.
- 2 Even numbers are required on the f row when using the lower surface ground plate (PCN21*, SB*-G).
- 3 For without ground the plate type, rows f and z unnecessary.
- 4 Board thickness: 1.6 to 4.2 mm

Product No.	A	B	C	D	E	F	G	Ground plate
PCN21*-125SB-2PF	49.95	48	20.7	7.3	125	—	25	Not provided
PCN21*-125SB-2PF-G	49.95	48	20.9	7.5	138	12	25	Provided
PCN21*-110SB-2PF	43.95	42	20.7	7.3	110	—	22	Not provided
PCN21*-110SB-2PF-G	43.95	42	20.9	7.5	121	11	22	Provided
PCN21*- 95SB-2PF	37.95	36	20.7	7.3	95	—	19	Not provided
PCN21*- 95SB-2PF-G	37.95	36	20.9	7.5	105	9	19	Provided

* A...PCB leads : Gold plating, B...PCB leads : Tin plating

■ Receptacle (Style C) [PKG-side female connector]

< With ground plate >

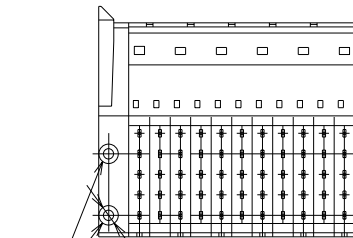
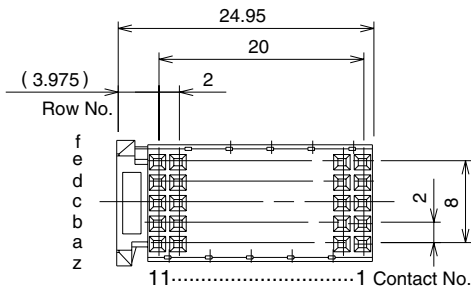
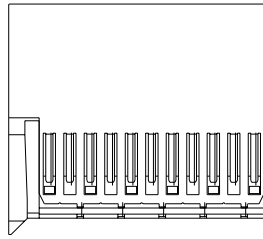

Peg 2-φ1.9

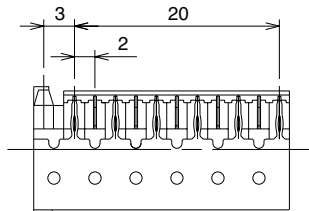

< Without ground plate >

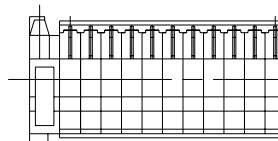
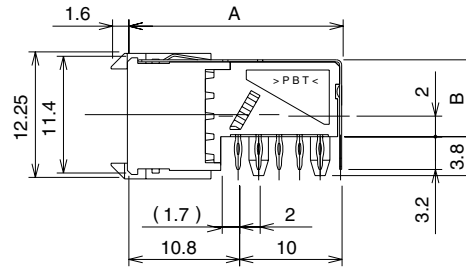
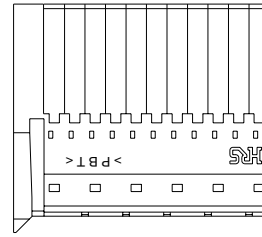

◆ Recommended PCB mounting pattern

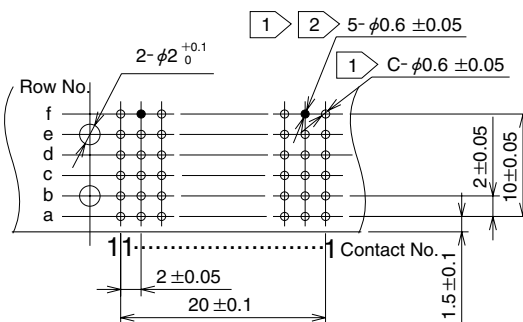

- 1 Through hole
Drilling diameter: $\phi 0.7 \pm 0.02$
Finishing diameter: $\phi 0.6 \pm 0.05$
Plating: Cu 25 μ m min.
- 2 Even numbers are required on the f row when using the lower surface ground plate (PCN21*, SC-G).
- 3 For without ground the plate type, rows f and z unnecessary.
- 4 The type without the peg does not require the 2mm dia. hole.
- 5 Board thickness: 1.6 to 4.2 mm

Product No.	A	B	C	Ground plate	Peg
PCN21*-55SC-2PF	20.7	7.3	55	Not provided	Provided
PCN21*-55SC-2PF-G	20.9	7.5	61	Provided	
PCN21*-55SCA-2PF	20.7	7.3	55	Not provided	Not provided
PCN21*-55SCA-2PF-G	20.9	7.5	61	Provided	

* A...PCB leads : Gold plating, B...PCB leads : Tin plating

■ Receptacle (Style M) [PKG-side female connector]

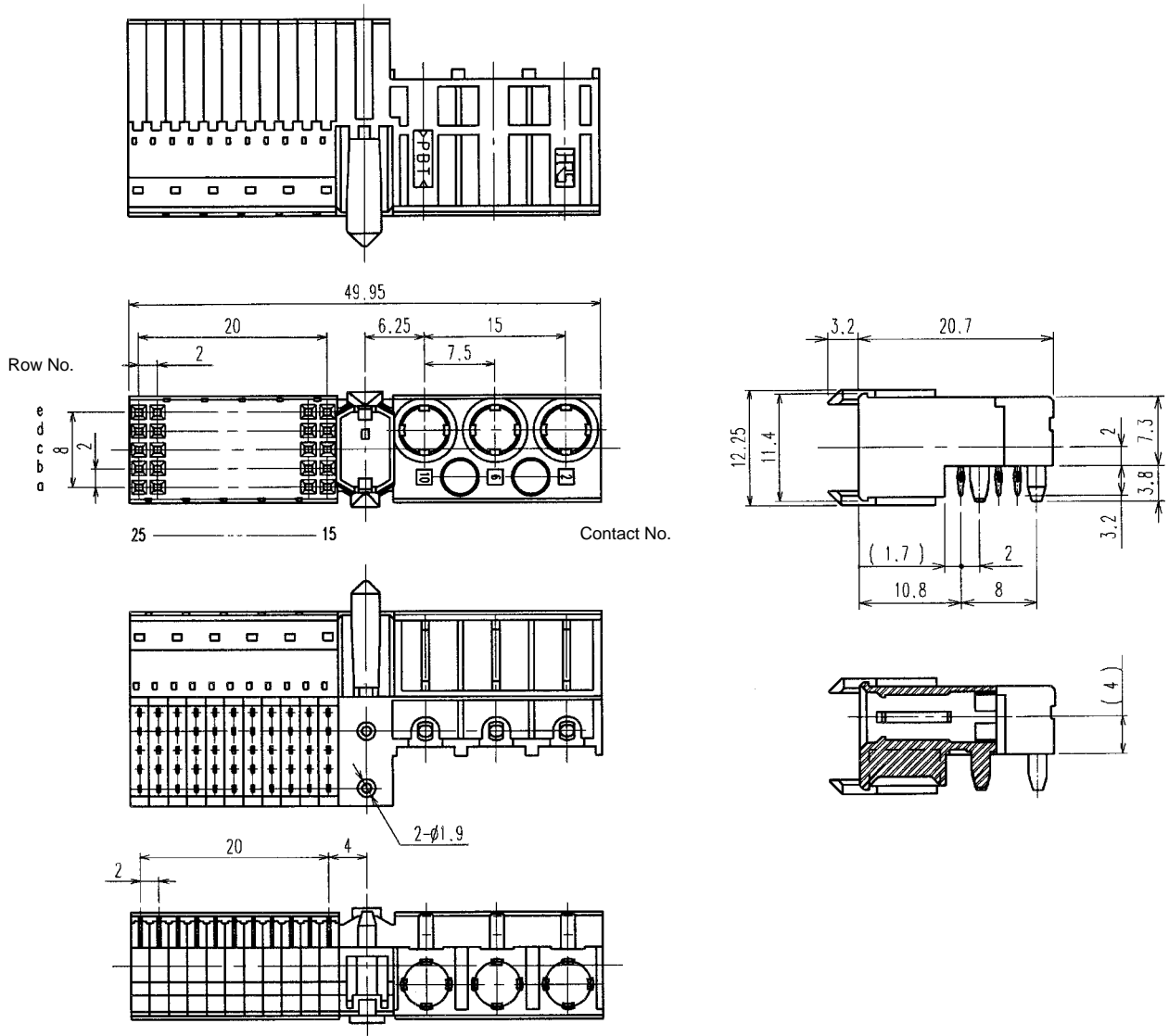

◆ Recommended Mounting Hole Pattern

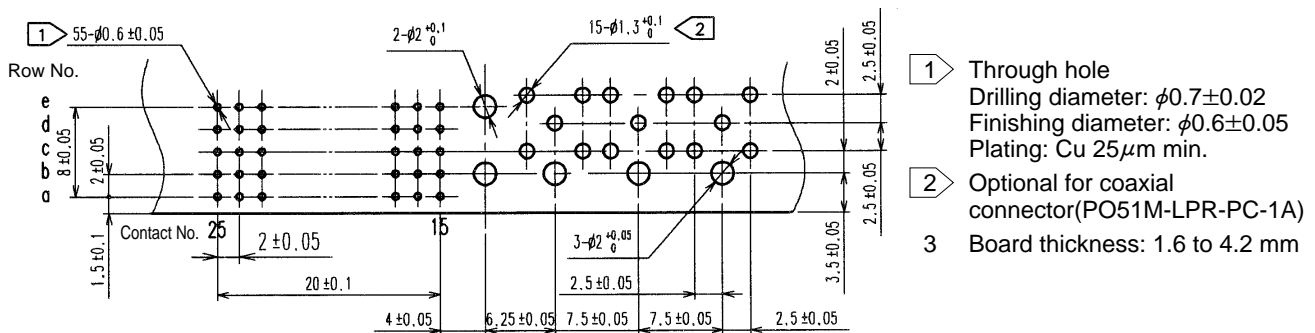

Product No.	Ground plate	Peg
PCN21*-55SM-2PF	Not provided	Provided

* A...PCB leads : Gold plating, B...PCB leads : Tin plating

■ Receptacle (Style AB) [PKG-side female connector]

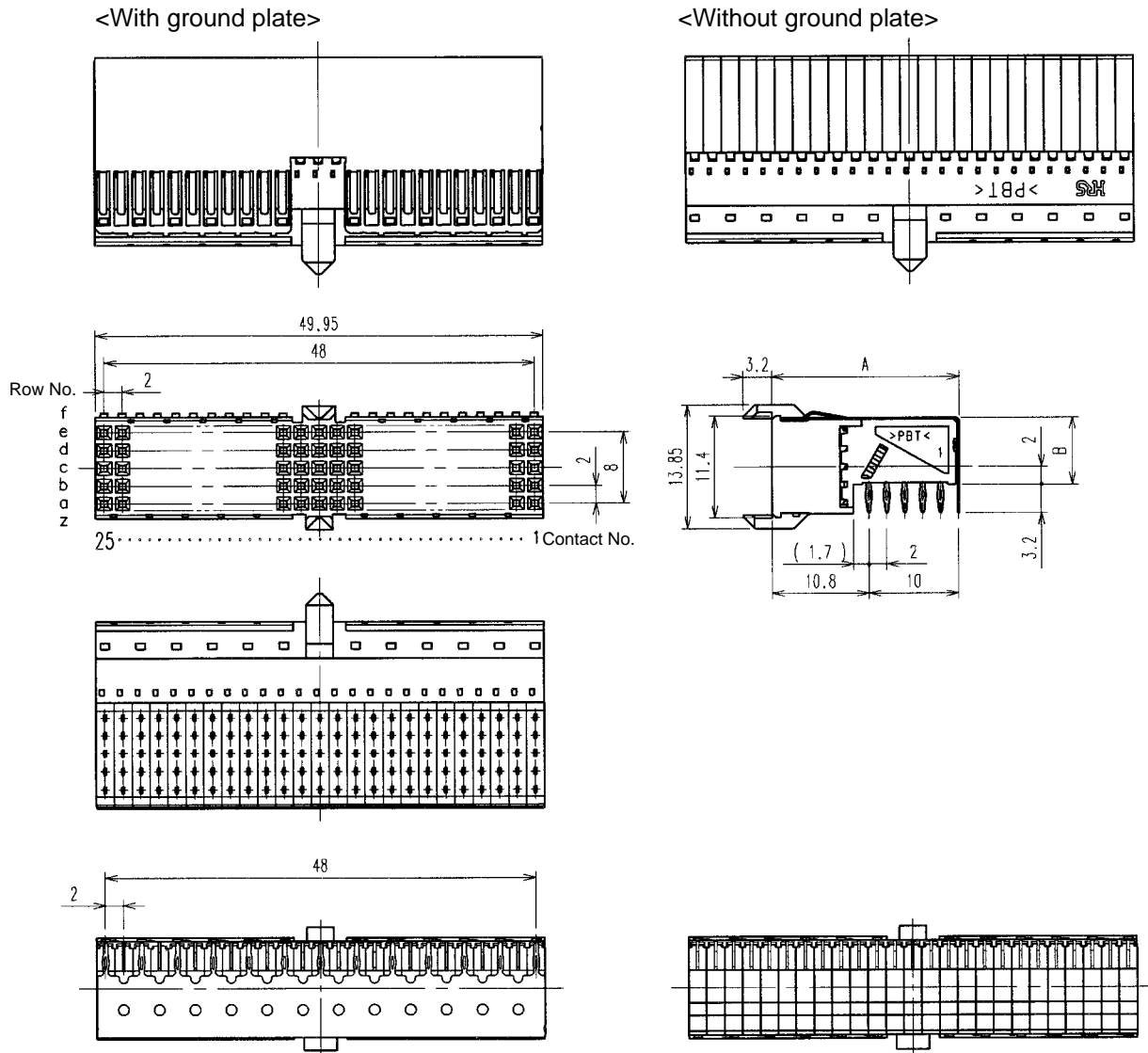

◆ Recommended PCB mounting pattern

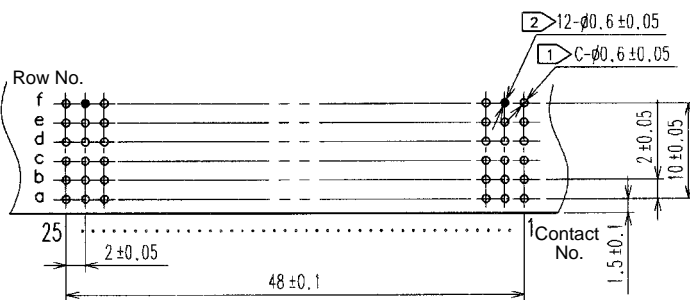

- 1) Through hole
Drilling diameter: $\phi 0.7 \pm 0.02$
Finishing diameter: $\phi 0.6 \pm 0.05$
Plating: Cu $25 \mu\text{m}$ min.
- 2) Even numbers are required on the f row when using the lower surface ground plate (PCN21*, SA-G).
- 3) For without ground the plate type, rows f and z unnecessary.
- 4) Board thickness: 1.6 to 4.2 mm

Product No.	A	B	C	Ground plate
PCN21*-125SAB-2PF	20.7	7.3	125	Not provided
PCN21*-125SAB-2PF-G	20.9	7.5	138	Provided

* A...PCB leads : Gold plating, B...PCB leads : Tin plating

Bottom ground plate for receptacle

PCN21A-SA-G

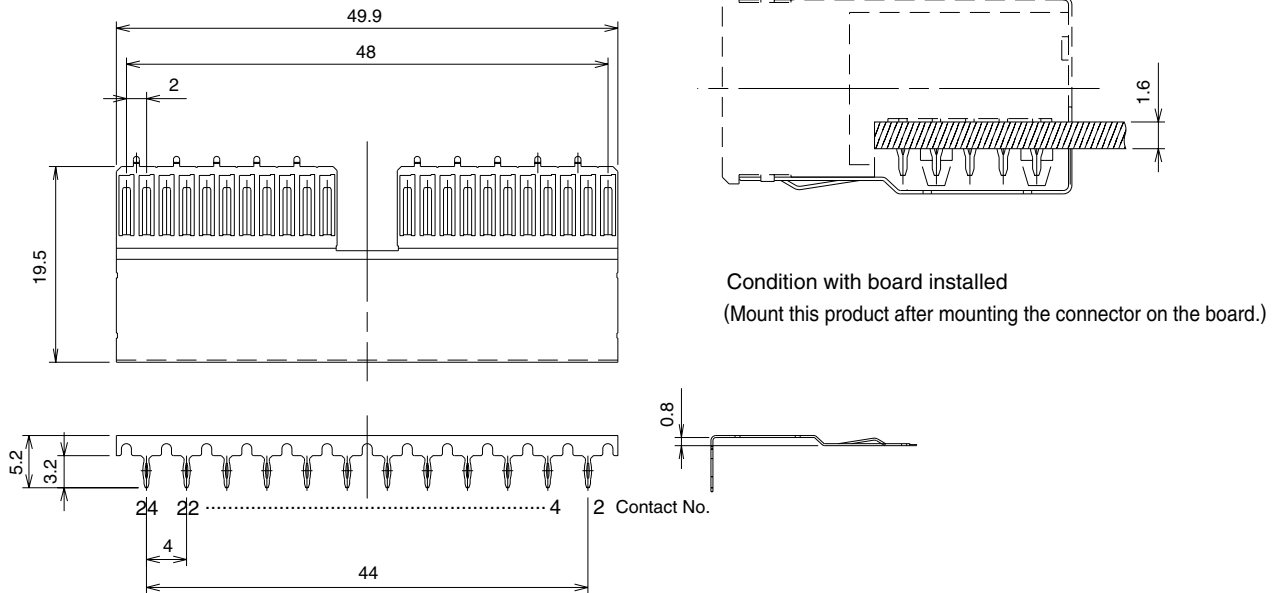

PCN21A-SB-G
PCN21A-SB1-G
PCN21A-SB2-G

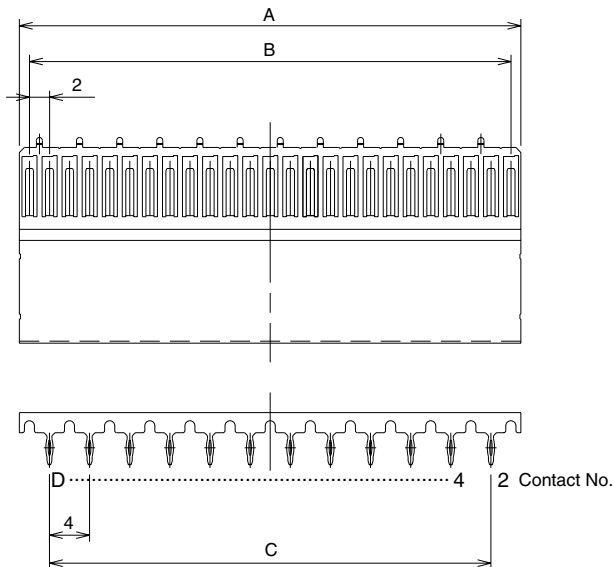

PCN21A-SC-G

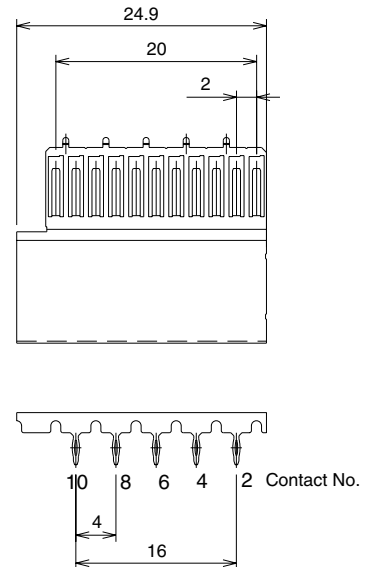

●Recommended board thickness: 1.6 mm

Product No.	A	B	C	D	Applicable connectors
PCN21*-SA-G	—	—	—	—	PCN21*-110SA-2PF-G
PCN21*-SB-G	49.9	48	44	24	PCN21*-125SB-2PF-G
PCN21*-SB1-G	43.9	42	40	22	PCN21*-110SB-2PF-G
PCN21*-SB2-G	37.9	36	32	18	PCN21*- 95SB-2PF-G
PCN21*-SC-G	—	—	—	—	PCN21*- 55SC-2PF-G

*A...PCB leads : Gold plating
B...PCB leads : Tin plating

Mid-plane (Shroud) [Style A]

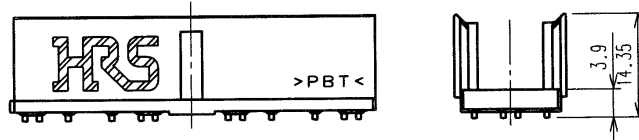
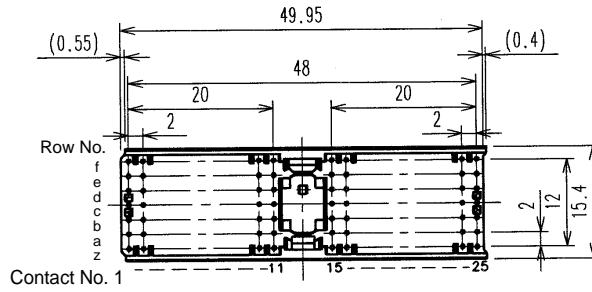

[Style B]

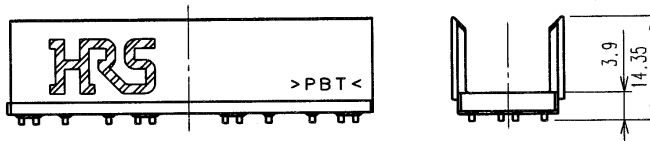
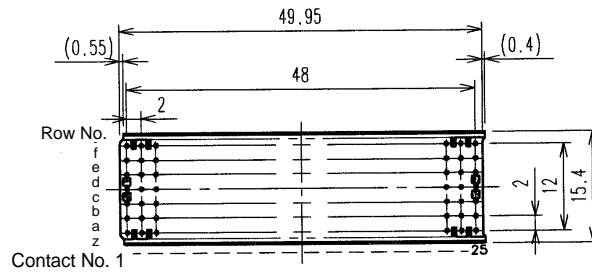

Product No.	Applicable connector
PCN21-110PA-2C1	PCN21*-110PA-2W-G
PCN21-125PB-2C1	PCN21*-125PB-2W-G

2 FIG.1

A	PCB thickness	2.4	3.2
B	Back-plane Contact Length	13	13
C	Shroud mating contact length	6.7	5.9

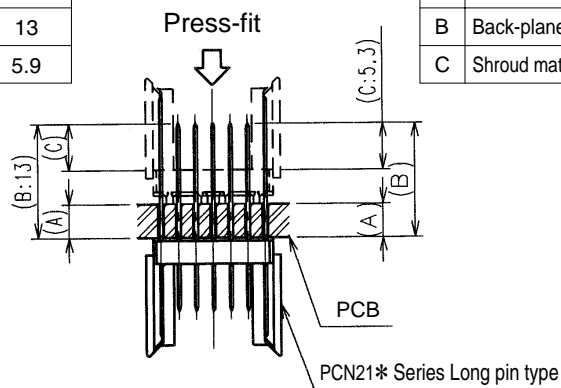

A	PCB thickness	3.8	5.3
B	Back-plane Contact Length	13	14.5
C	Shroud mating contact length	5.3	5.3

■ Coding key

This can be installed on Style A to prevent improper insertion.

Header

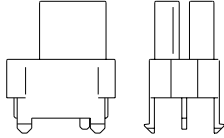
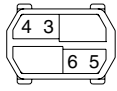

Receptacle

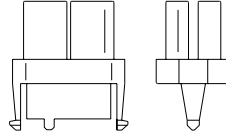
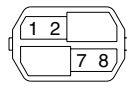

Header		Receptacle		Color	Remark
Product No.	Type	Product No.	Type		
PCN21-P-CK(A)	3456	PCN21-S-CK(A)	1278	Yellow	Supports Compact PCI 3.3V
PCN21-P-CK(B)	1567	PCN21-S-CK(B)	2348	Blue	Supports Compact PCI 5V

◆ Header Contacts

Custom support for header sequenced contacts is available. Please contact a Hirose sales representative.

Use of rows of contacts having the same length is recommended.

Contact Code

A B C K L M N P Q R S T

PKG Side

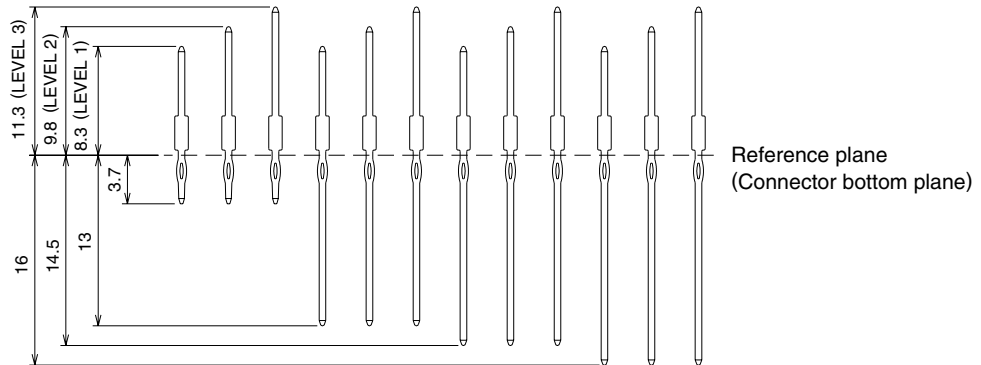

BWB Side

◆ Mating conditions

● Lateral and longitudinal mating

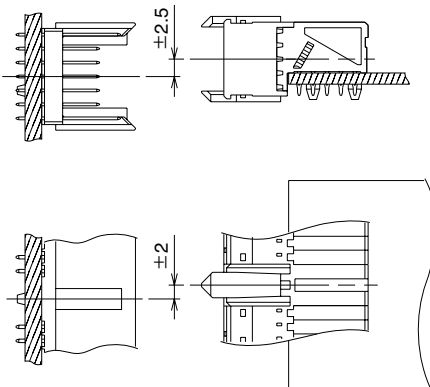

● Oblique mating

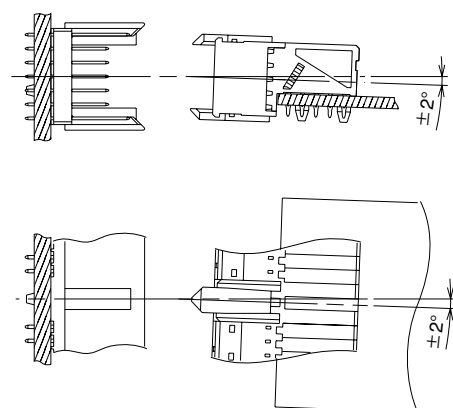

MEMO :

A series of horizontal dashed lines for writing.

USA:**HIROSE ELECTRIC U.S.A., INC.**

2688 Westhills Court, Simi Valley, CA 93065-6235

Phone : 1 805 522 7958

Fax : 1 805 522 3217

<http://www.hirose.com>**UNITED KINGDOM:****HIROSE ELECTRIC UK LTD.**Crownhill Business Centre 22 Vincent Avenue
Crownhill, Milton Keynes MK8 OAB

Phone : 44 1908 305400

Fax : 44 1908 305401

<http://www.hirose.co.uk>**HONG KONG:****HIROSE ELECTRIC CO., LTD.**Unit 506, Energy Plaza. 92 Granville Road, Tsim Sha
Tsui East, Kowloon

Phone : 852 2803 5338

Fax : 852 2591 6560

EUROPE BRANCH:**HIROSE ELECTRIC CO., LTD.**First Class Building 4F, Beechavenue 46.1119PV
Schiphol-Rijk, The Netherlands

Phone : 31 20 6557 460

Fax : 31 20 6557 469

<http://hiroseeurope.com>**KOREA:****HIROSE KOREA CO., LTD.**

(#2NA311, Shihwa Industrial Complex),

1261-10, Jeoungwhang-Dong, Shihung-City, Kyunggi-Do

Phone : 82 31 496 7000,7124

Fax : 82 31 496 7101

<http://www.hirose.co.kr>**TAIWAN:****HIROSE ELECTRIC CO., LTD.**

No.28 Lane 247 Sec. 2 Yen Ping N,Rd.Taipei

Phone : 886 2 2557 7351,7352

Fax : 886 2 2552 9851

GERMANY:**HIROSE ELECTRIC GmbH**

Zeppelinstrasse 42 D-73760 Ostfildern Kemnat

Phone : 49 711 4560021

Fax : 49 711 4560729

<http://www.hirose.de>**CHINA:****HIROSE ELECTRIC CO., LTD.**

10F, No.06, Shanghai Times Square office Tower,

93. Huai Hai Zhong Road, Luwan Shanghai

Phone : 86 21 6391 0011

Fax : 86 21 6391 0101

SINGAPORE:**HIROSE ELECTRIC CO., LTD.**

10 Anson Road #34-13 International Plaza 079903

Phone : 65 6324 6113

Fax : 65 6324 6123

HRS

HIROSE ELECTRIC CO., LTD.
5-23, OSAKI 5-CHOME, SHINAGAWA-KU, TOKYO 141-8587, JAPAN
PHONE: 81-3-3491-9741, FAX: 81-3-3493-2933
