

阅读申明

- 1.本站收集的数据手册和产品资料都来自互联网，版权归原作者所有。如读者和版权方有任何异议请及时告之，我们将妥善解决。
- 2.本站提供的中文数据手册是英文数据手册的中文翻译，其目的是协助用户阅读，该译文无法自动跟随原稿更新，同时也可能存在翻译上的不当。建议读者以英文原稿为参考以便获得更精准的信息。
- 3.本站提供的产品资料，来自厂商的技术支持或者使用者的心得体会等，其内容可能存在描述上的差异，建议读者做出适当判断。
- 4.如需与我们联系，请发邮件到marketing@iczoom.com，主题请标有“数据手册”字样。

Read Statement

1. The datasheets and other product information on the site are all from network reference or other public materials, and the copyright belongs to the original author and original published source. If readers and copyright owners have any objections, please contact us and we will deal with it in a timely manner.
2. The Chinese datasheets provided on the website is a Chinese translation of the English datasheets. Its purpose is for reader's learning exchange only and do not involve commercial purposes. The translation cannot be automatically updated with the original manuscript, and there may also be improper translations. Readers are advised to use the English manuscript as a reference for more accurate information.
3. All product information provided on the website refer to solutions from manufacturers' technical support or users the contents may have differences in description, and readers are advised to take the original article as the standard.
4. If you have any questions, please contact us at marketing@iczoom.com and mark the subject with "Datasheets" .

JD series

Screw Terminal Type, High Energy Density Type

- High energy density.
- Suitable for electric power storage.
- Available for adapted to the RoHS directive (2002/95/EC).

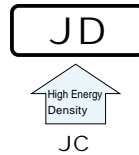

Specifications

Item	Performance Characteristics		
Category Temperature Range	- 25 to + 60°C		
Rated Voltage Range	2.5V		
Rated Capacitance Range	600 to 4000F See Note		
Capacitance Tolerance	± 20% (20°C)		
Leakage Current	0.5C (mA) [C : Rated Capacitance (F)] (After 30 minutes' application of rated voltage. 2.5V)		
Stability at Temperature	Capacitance (- 25°C) / Capacitance (+20°C) × 100 ≥ 70% DCR(-25°C) / DCR (+20°C) ≤ 7		
DCR*	Refer to the list below. (20°C) *DC internal resistance		
Endurance	The specifications listed at right shall be met when the capacitors are restored to 20°C after the rated voltage is applied for 2000 hours at 60°C.	Capacitance change	Within ±30% of initial value
		DCR	300% or less of initial specified value
		Leakage current	Less than or equal to the initial specified value
Shelf Life	The specifications listed at right shall be met when the capacitors are restored to 20°C after storing the capacitors under no load for 2000 hours at 60°C.	Capacitance change	Within ±30% of initial value
		DCR	300% or less of initial specified value
		Leakage current	Less than or equal to the initial specified value
Marking	Printed with white color letter on black sleeve.		

Drawing

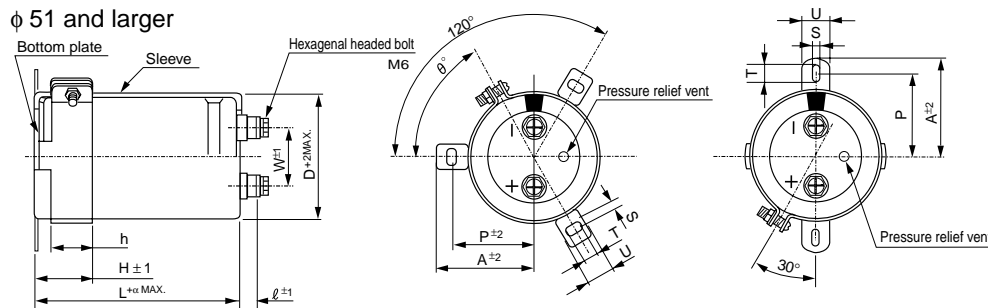
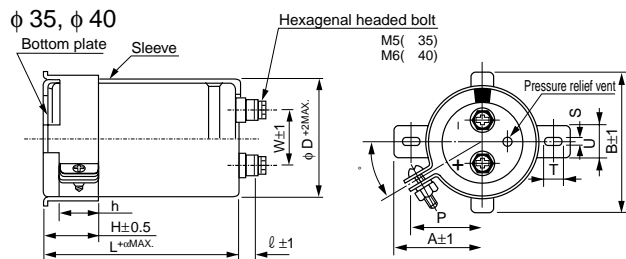

Type numbering system (Example : 2.5V 600F)

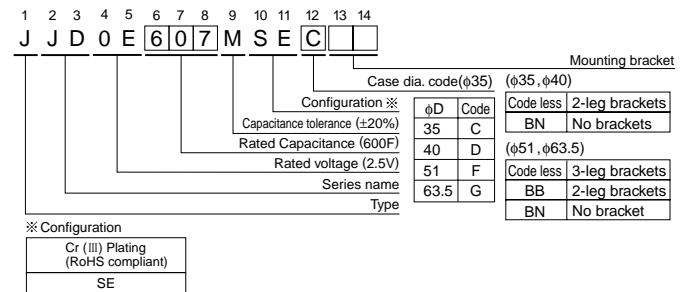

Dimensions

Rated Voltage (Code)	Cap. (F)	Cap. code	DCR (mΩ)	Case size		Ref. Weight (g)
				φ (mm)	L (mm)	
2.5V (0E)	600	607	16	35	85	130
	800	807	13		105	160
	950	957	10		135	210
	1000	108	10		105	210
	1300	138	8	51	135	250
	2300	238	5		135	450
	2500	258	4		150	500
	4000	408	3		63.5	150

Dimensions of terminal pitch(W) and length(ℓ) and Normal dia. of bolt (mm)

φ D	W	ℓ	α	Nominal of bolt
35	12.7	6	3	M5
40	18.8	9	3	M6
51	22.0	10	3	M6
63.5	28.6	10	3	M6

Dimensions of mounting bracket (mm)

Symbol	φ D	3-Legs		2-Legs			
		51	63.5	35	40	51	63.5
P		32.5	38.1	24	27	33.2	40.5
A		38.5	43	29	32	40	46.5
B		-	-	45	48	-	-
T		7.5	8.0	7.0	7.0	6.0	7.0
S		5.0	5.0	3.5	3.5	4.5	4.5
U		12	14	10	10	14	14
θ°		60	60	30	45	30	30
H		20	25	15	17	25	35
h		15	20	10	12	15	20

Note :

The capacitance calculated from discharge time (ΔT) with constant current (i) after 30minute charge with rated voltage (2.5V).

The discharge current (i) is 0.01 × F (rated capacitance).

A discharge time (ΔT) measured between 2V and 1V with constant current.

The capacitance calculated bellow.

$$\text{Capacitance (F)} = i \times \Delta T$$

CAT.8100X