

阅读申明

- 1.本站收集的数据手册和产品资料都来自互联网，版权归原作者所有。如读者和版权方有任何异议请及时告之，我们将妥善解决。
- 2.本站提供的中文数据手册是英文数据手册的中文翻译，其目的是协助用户阅读，该译文无法自动跟随原稿更新，同时也可能存在翻译上的不当。建议读者以英文原稿为参考以便获得更精准的信息。
- 3.本站提供的产品资料，来自厂商的技术支持或者使用者的心得体会等，其内容可能存在描述上的差异，建议读者做出适当判断。
- 4.如需与我们联系，请发邮件到marketing@iczoom.com，主题请标有“数据手册”字样。

Read Statement

1. The datasheets and other product information on the site are all from network reference or other public materials, and the copyright belongs to the original author and original published source. If readers and copyright owners have any objections, please contact us and we will deal with it in a timely manner.
2. The Chinese datasheets provided on the website is a Chinese translation of the English datasheets. Its purpose is for reader's learning exchange only and do not involve commercial purposes. The translation cannot be automatically updated with the original manuscript, and there may also be improper translations. Readers are advised to use the English manuscript as a reference for more accurate information.
3. All product information provided on the website refer to solutions from manufacturers' technical support or users the contents may have differences in description, and readers are advised to take the original article as the standard.
4. If you have any questions, please contact us at marketing@iczoom.com and mark the subject with "Datasheets" .

Panel feed-through - Q 1,5/3L90/13KU-DSI - 1670413

Please be informed that the data shown in this PDF Document is generated from our Online Catalog. Please find the complete data in the user's documentation. Our General Terms of Use for Downloads are valid (<http://download.phoenixcontact.com>)



Panel feed-through, for internal wall mounting, with dip-solder connection, length of the solder pin: 3.8 mm, hole Ø 3-pos. = 20.8 mm - 0.3



Key commercial data

Packing unit	1 pc
Minimum order quantity	10 pc
GTIN	 4 017918 153199
Weight per Piece (excluding packing)	25.58 GRM
Custom tariff number	85366990
Country of origin	Poland

Technical data

General

Connection	If the conductor is reconnected, it must be cut off above the last contact point. QUICKON components may only be operated when under no load.
Color	green
Connection method	QUICKON connection Dip-solder connection
Note on the internal connection type	The product must be screwed to the PCB before soldering. Self-tapping screws in acc. with ISO 1481-ST 2,9 x 6,5 C.
Number of positions	3
Wrench size, union nut	24 mm
Tightening torque, union nut	2.5 Nm
Wrench size, contact carrier	24 mm
Tightening torque contact carrier	3.75 Nm
Tightening torque, counter nut	3.75 Nm

Panel feed-through - Q 1,5/3L90/13KU-DSI - 1670413

Technical data

General

Number of connections	3
Conductor cross section stranded min.	0.75 mm ²
Conductor cross section stranded max.	1.5 mm ²
Conductor cross section AWG/kcmil min.	18
Conductor cross section AWG/kcmil max	16

Conductor

Structure of individual litz in acc. with VDE 0295 / smallest wire diameter	VDE 0295 Cl.2-5, min. wire diameter 0.2 mm
Wire insulation material	PVC/PE
Wire diameter including insulation	>= 3 mm

Ambient conditions

Degree of protection	IP65
	IP67
Ambient temperature (operation)	-25 °C ... 80 °C
	-25 °C ... 50 °C (when the conductor is connected. Specifications of the cable manufacturer must also be observed.)

Electrical characteristics

Nominal current I _N	17.5 A
Rated voltage (III/3)	250 V
Rated voltage (III/2)	320 V
Rated voltage (II/2)	630 V

Mechanical characteristics

QUICKON connectability	10 (if the conductor is connected more than once, seal and cap may need to be replaced.)
PC QUICKON thread type	Pg13.5
Impact category	4

Material data

Contact material	Copper alloy
Contact surface material	Pre-nickel plated and tin-plated
Contact carrier material	PA 66
Inflammability class according to UL 94	V0
Surge voltage category	III
Pollution degree	3

Panel feed-through - Q 1,5/3L90/13KU-DSI - 1670413

Classifications

eCl@ss

eCl@ss 4.0	27140815
eCl@ss 4.1	27140815
eCl@ss 5.0	27143423
eCl@ss 5.1	27143423
eCl@ss 6.0	27143423
eCl@ss 7.0	27449001
eCl@ss 8.0	27449001

ETIM

ETIM 2.0	EC001297
ETIM 3.0	EC000516
ETIM 4.0	EC000516
ETIM 5.0	EC000516

UNSPSC

UNSPSC 6.01	30211923
UNSPSC 7.0901	39121522
UNSPSC 11	39121522
UNSPSC 12.01	39121522
UNSPSC 13.2	39121522

Approvals

Approvals

Approvals

UL Recognized / cUL Recognized / GOST / cULus Recognized

Ex Approvals

Approvals submitted

Approval details

Panel feed-through - Q 1,5/3L90/13KU-DSI - 1670413

Approvals

UL Recognized	
Nominal current IN	15 A
Nominal voltage UN	250 V

cUL Recognized	
Nominal current IN	11 A
Nominal voltage UN	250 V

GOST	
------	--

cULus Recognized	
------------------	--

Accessories

Accessories

Flat nut

Mounting material - Q-MU PG13,5 M - 1670905



Counter nut, (metal), to lock the contact carrier in the case of aligning

Mounting material

Panel feed-through - Q 1,5/3L90/13KU-DSI - 1670413

Accessories

Nut - Q-MU PG13,5 - 1670484



Nut (plastic) to lock the contact carrier Pg13.5 / 27 WAF

Nut - Q-MU PG11 - 1670471



Nut (plastic) to lock the contact carrier Pg11 / 24 WAF

Protective cap

Filler plugs - Q-PROT13/16 - 1670222



Closing caps, for Pg13/ Pg16, for closing unoccupied connections

Filler plugs - Q-PROT 9/11 - 1670235



Closing cap for Pg9/Pg11 to close unoccupied connections

Nut - Q-SMU PG13,5 SET - 1670756



Locking nut, can only be released with wrench, Pg13.5/ WAF 24, coding 1

Panel feed-through - Q 1,5/3L90/13KU-DSI - 1670413

Drawings

Drilling diagram

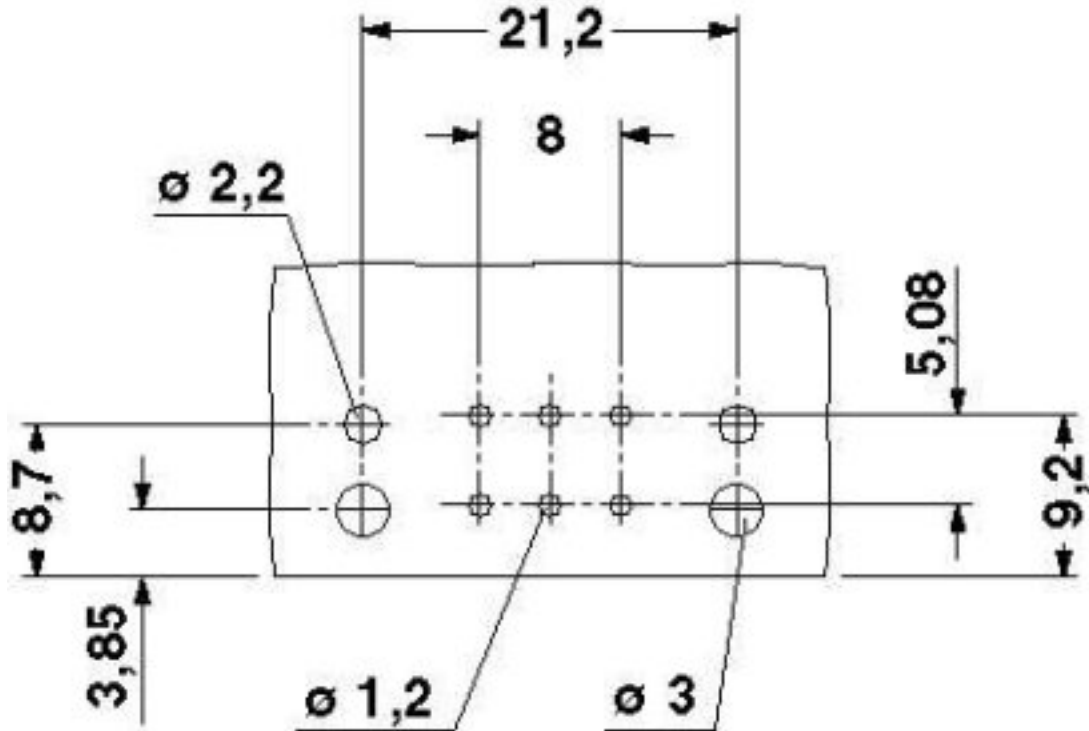

Dimensioned drawing

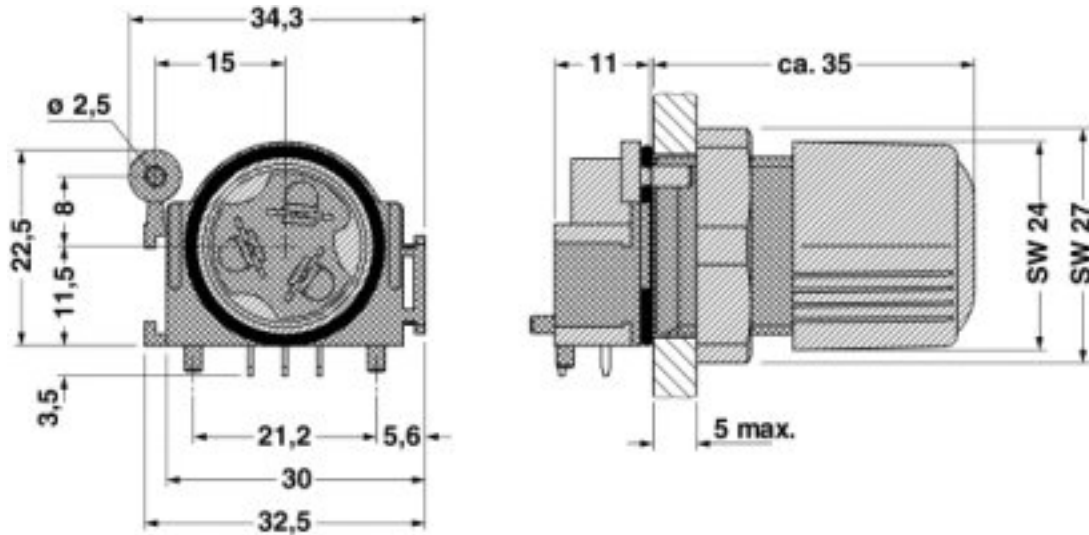

Panel feed-through - Q 1,5/3L90/13KU-DSI - 1670413

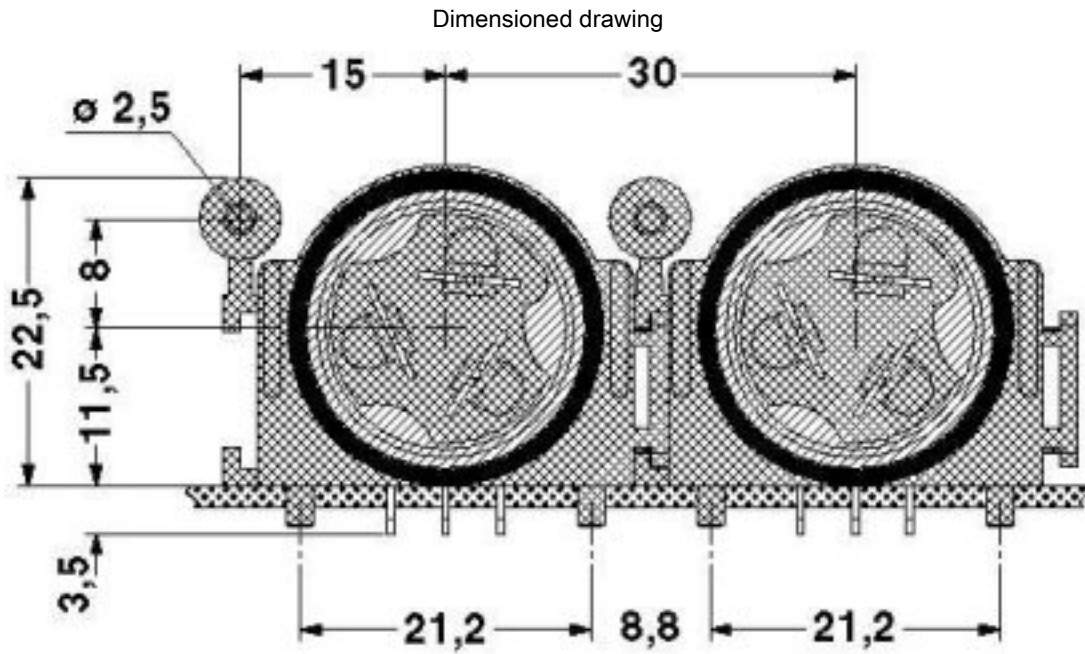

For aligning PCB versions, 30 mm pitch, Pg13,5 in rows. To lock the contact carrier, the Q-MU PG 13,5 M nut should be used.