

阅读申明

- 1.本站收集的数据手册和产品资料都来自互联网，版权归原作者所有。如读者和版权方有任何异议请及时告之，我们将妥善解决。
- 2.本站提供的中文数据手册是英文数据手册的中文翻译，其目的是协助用户阅读，该译文无法自动跟随原稿更新，同时也可能存在翻译上的不当。建议读者以英文原稿为参考以便获得更精准的信息。
- 3.本站提供的产品资料，来自厂商的技术支持或者使用者的心得体会等，其内容可能存在描述上的差异，建议读者做出适当判断。
- 4.如需与我们联系，请发邮件到marketing@iczoom.com，主题请标有“数据手册”字样。

Read Statement

1. The datasheets and other product information on the site are all from network reference or other public materials, and the copyright belongs to the original author and original published source. If readers and copyright owners have any objections, please contact us and we will deal with it in a timely manner.
2. The Chinese datasheets provided on the website is a Chinese translation of the English datasheets. Its purpose is for reader's learning exchange only and do not involve commercial purposes. The translation cannot be automatically updated with the original manuscript, and there may also be improper translations. Readers are advised to use the English manuscript as a reference for more accurate information.
3. All product information provided on the website refer to solutions from manufacturers' technical support or users the contents may have differences in description, and readers are advised to take the original article as the standard.
4. If you have any questions, please contact us at marketing@iczoom.com and mark the subject with "Datasheets" .

DESCRIPTION: MALE - DIP SOLDER - HIGH PROFILE

DIMENSIONS

No. OF PINS	A	B	C	D	E	F	G
9	1.213	0.984	0.669	0.331	0.618	0.496	0.429
	30.80	24.99	17.00	8.40	15.70	12.60	10.90
15	1.541	1.312	0.996	0.331	0.933	0.496	0.429
	39.15	33.32	25.30	8.40	23.70	12.60	10.90
25	2.088	1.852	1.535	0.331	1.496	0.496	0.429
	53.04	47.04	39.00	8.40	38.00	12.60	10.90
37	2.729	2.500	2.181	0.331	2.142	0.496	0.429
	69.32	63.50	55.40	8.40	54.40	12.60	10.90
50	2.635	2.406	2.079	0.437	2.039	0.602	0.535
	66.93	61.11	52.80	11.10	51.80	15.30	13.60

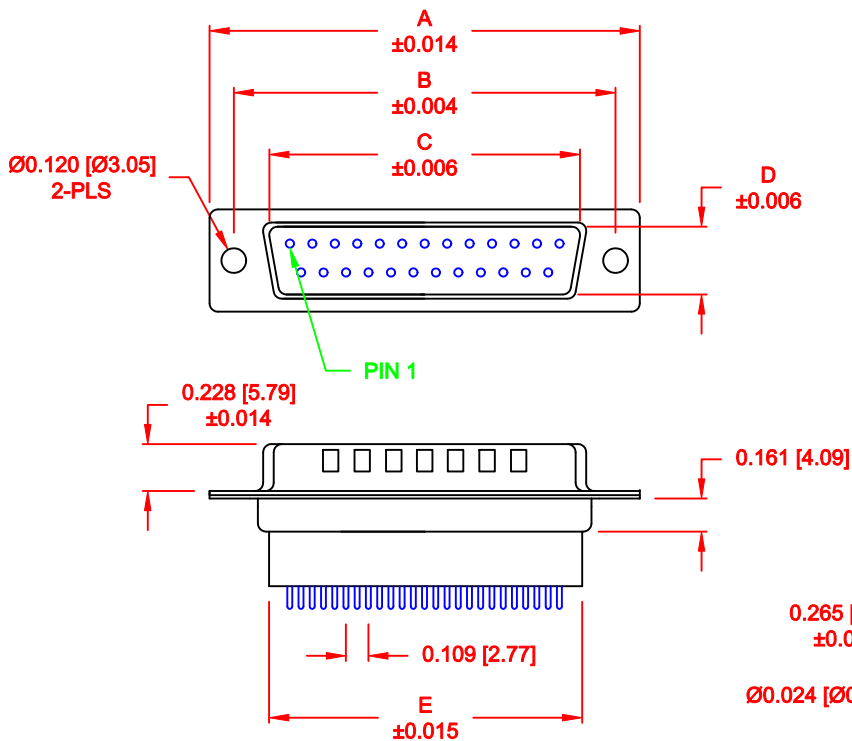

3 ROWS

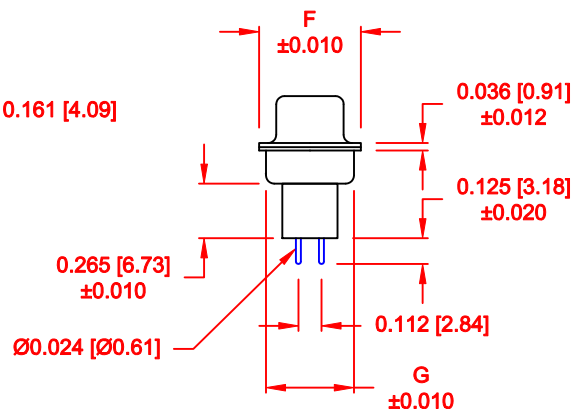

172-YYY-181LYY1

- SERIES _____
- POSITIONS _____
- 009 _____
- 015 _____
- 025 _____
- 037 _____
- 050 _____
- GENDER _____
- 1 = MALE _____
- TERMINATION _____
- 8 = HIGH PROFILE VERTICAL _____
- SHELL PLATING _____
- 1 = YELLOW CHROMATE (NON-ROHS) _____
- HARDWARE OPTIONS _____
- 00 = NO HARDWARE _____
- 01 = .098" CLINCH NUT (BOARD SIDE) _____
- 02 = .236" CLINCH NUT (BOARD SIDE) _____
- 03 = .236" CLINCH NUT (MATING SIDE) _____
- PLATING OPTIONS _____
- 1 = GOLD FLASH _____
- 2 = 30u" GOLD _____

MATERIAL:

SHELL: STEEL, YELLOW CHROMATE
 INSULATOR: UL 94V-O RATED, PBT
 +30% FIBER-GLASS OR NYLON-66

ELECTRICAL:

CURRENT RATING: 5 AMPS
 CONTACT RESISTANCE: 15 mOhms Max.
 INSULATION RESISTANCE: 1,000 MOhms min.
 VOLTAGE: 500VAC FOR 1 MINUTE
 TEMPERATURE: -50° C TO 125° C

DO NOT SCALE FROM DRAWING

	THESE DRAWINGS AND SPECIFICATIONS ARE THE PROPERTY OF NorComp AND SHALL NOT BE REPRODUCED, COPIED OR USED AS THE BASIS FOR THE MANUFACTURE OF SALE OF APPARATUS WITHOUT WRITTEN PERMISSION.		DRAWN: WAYNE ROBBINS	DATE: 08-23-98
			CHECKED:	DATE:
NorComp	SCALE: 1:1	SHEET 1 OF 3	REV 1	
	DWG NO. 172-YYY-181LYY1			

DESCRIPTION: PCB LAYOUT - STANDARD "D" - MALE & FEMALE

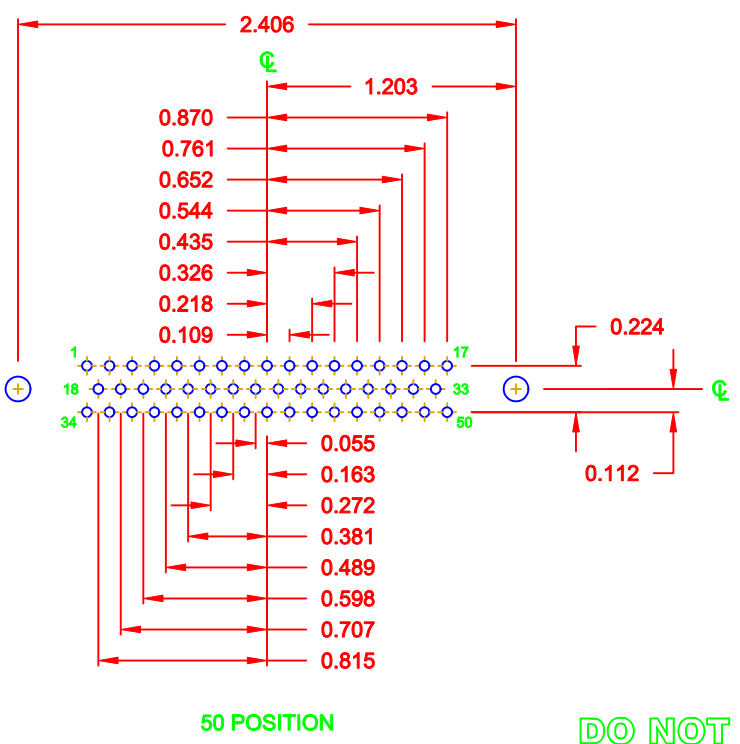
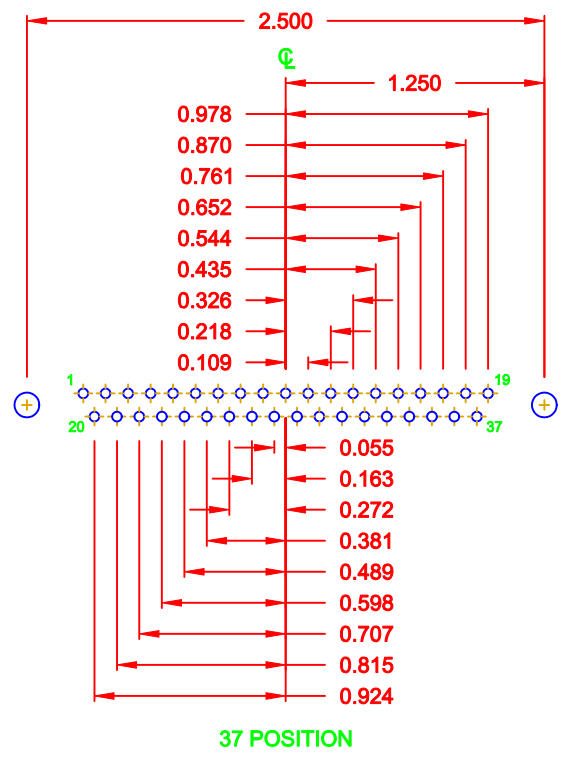
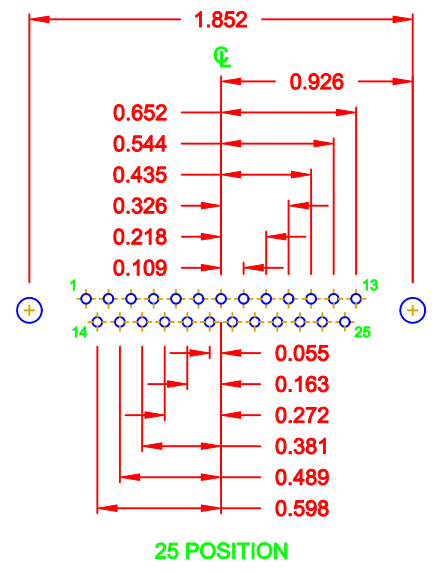
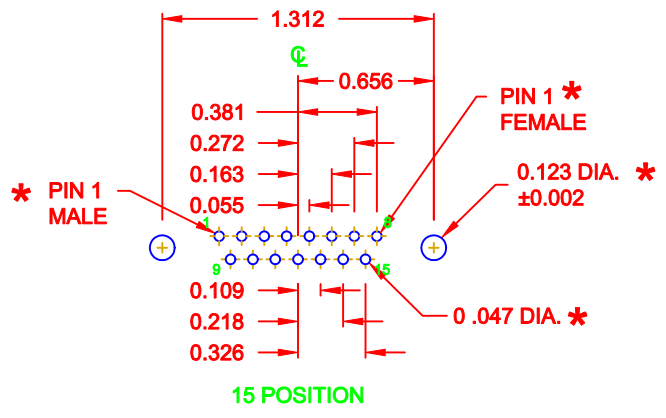
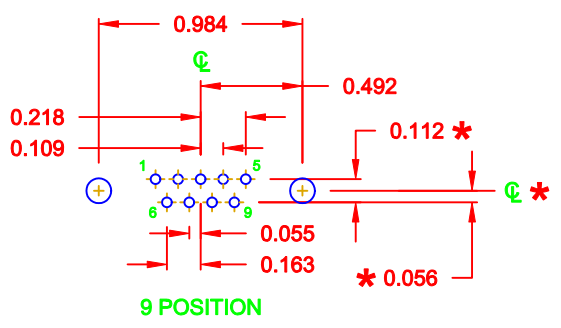

* TYP. ON ALL SIZES

DO NOT SCALE FROM DRAWING

	THESE DRAWINGS AND SPECIFICATIONS ARE THE PROPERTY OF NorComp AND SHALL NOT BE REPRODUCED, COPIED OR USED AS THE BASIS FOR THE MANUFACTURE OF SALE OF APPARATUS WITHOUT WRITTEN PERMISSION.		DRAWN: C. SMITH	DATE: 03-08-06
			CHECKED:	DATE:
NorComp	SCALE: FULL	SHEET 2 OF 3	REV 1	
	DWG NO. 172-YYY-181LYY1			

DESCRIPTION: CLINCH NUT HARDWARE

TOLERANCE:
ALL DIMENSIONS ARE ± 0.010

ALL CLINCH-NUTS ARE 4-40 INTERNAL THREADS

01X 0.065" (BOARD SIDE) - CN1

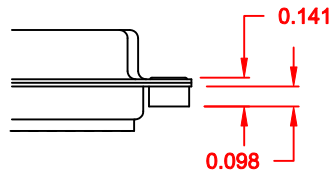

02X 0.236" (BOARD SIDE) - CN2

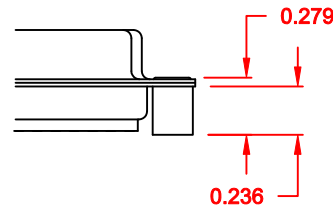

03X..... 0.236" (MATING SIDE) - CN8

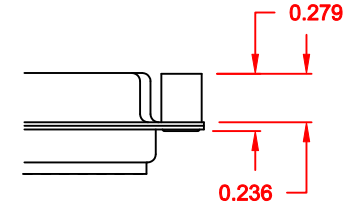

DO NOT SCALE FROM DRAWING



THESE DRAWINGS AND SPECIFICATIONS ARE THE PROPERTY OF NorComp AND SHALL NOT BE REPRODUCED, COPIED OR USED AS THE BASIS FOR THE MANUFACTURE OF SALE OF APPARATUS WITHOUT WRITTEN PERMISSION.

DRAWN:
WAYNE ROBBINS

DATE:
11-28-05

CHECKED:

DATE:

NorComp

SCALE: SHEET 3 OF 3 REV 1

DWG NO. **172-YYY-181LYY1**