

阅读申明

- 1.本站收集的数据手册和产品资料都来自互联网，版权归原作者所有。如读者和版权方有任何异议请及时告之，我们将妥善解决。
- 2.本站提供的中文数据手册是英文数据手册的中文翻译，其目的是协助用户阅读，该译文无法自动跟随原稿更新，同时也可能存在翻译上的不当。建议读者以英文原稿为参考以便获得更精准的信息。
- 3.本站提供的产品资料，来自厂商的技术支持或者使用者的心得体会等，其内容可能存在描述上的差异，建议读者做出适当判断。
- 4.如需与我们联系，请发邮件到marketing@iczoom.com，主题请标有“数据手册”字样。

Read Statement

1. The datasheets and other product information on the site are all from network reference or other public materials, and the copyright belongs to the original author and original published source. If readers and copyright owners have any objections, please contact us and we will deal with it in a timely manner.
2. The Chinese datasheets provided on the website is a Chinese translation of the English datasheets. Its purpose is for reader's learning exchange only and do not involve commercial purposes. The translation cannot be automatically updated with the original manuscript, and there may also be improper translations. Readers are advised to use the English manuscript as a reference for more accurate information.
3. All product information provided on the website refer to solutions from manufacturers' technical support or users the contents may have differences in description, and readers are advised to take the original article as the standard.
4. If you have any questions, please contact us at marketing@iczoom.com and mark the subject with "Datasheets" .

MU Type Fiber Optic Connectors

HMU Series

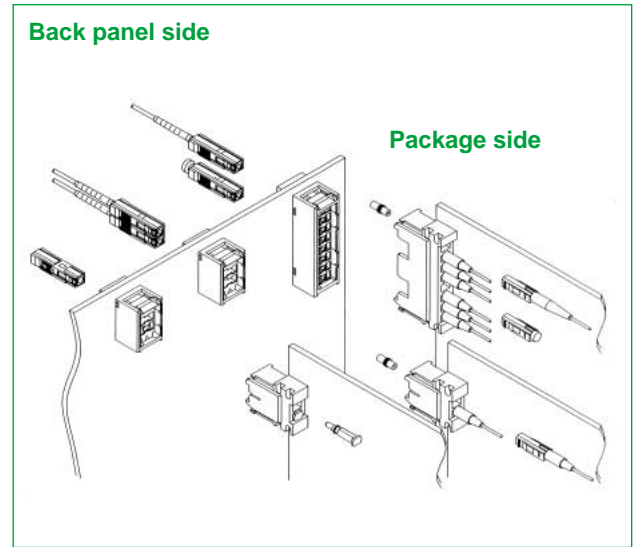
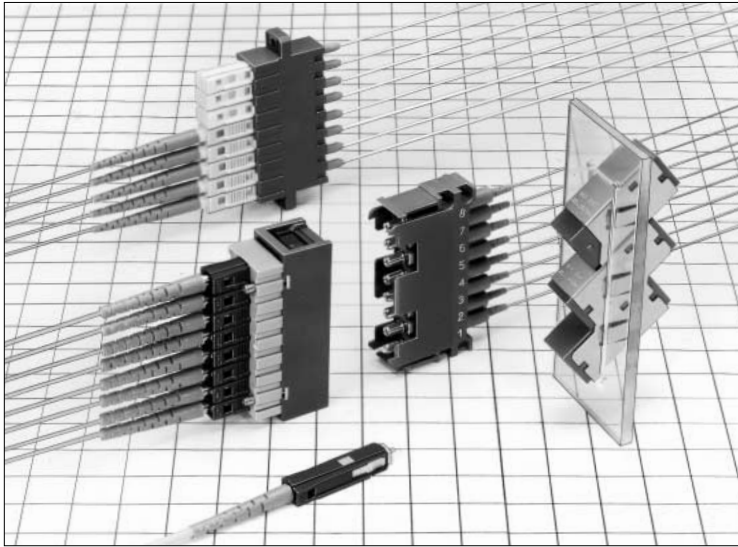

■ Features

1. JIS, IEC standard compliant and intermateability test certified.

Comply with JIS C 5983 (F14 type fiber optic connectors) and IEC 61754-6.
MU intermate test by NTT certified connector.

2. Flame resistant

Satisfies flammability rating UL94-V0

3. Backplane

MU Backplane connector has a self-holding mechanism which does not transfer any force on the back panel when both side of connector assemblies are fully connected. Back panel side connectors can be removed or inserted even both sides are mated.

4. Wide Variety of adapter type

Type	Number of Fiber connections				
	Single	Duplex	4 way	8 way	16 way
Board Mounting	○	○	—	○	—
Snap-in Panel Mounting & Screw Panel Mounting	○	○	○	○	○

5. Simplified plugs and Receptacles

Extremely small size (only 13.75mm Plug length). MU simplified plug is designed for equipments inside connection.

■ Applications

Optical terminal equipment, optical relay racks, test equipment, telecommunication equipment and other systems requiring Small Form Factor optical connections.

Please contact us if you have any requests. Hirose will offer excellent solutions to meet your requirements.

■ Product Specifications

Ratings	Operating temperature range	-25°C to +70°C	Storage temperature range	-25°C to +70°C
---------	-----------------------------	----------------	---------------------------	----------------

Item		Test Method (IEC 61300/JIS C 5961)		Specifications
Optical Characteristics	Insertion Loss	SM	Wavelength 1310nm (LD)	0.5dB max. (AdPC)
		MM(GI)	Wavelength 1310nm (LED)	0.3dB max. (AdPC)
Optical Characteristics	Return Loss	SM	Wavelength 1310nm (LD)	40dB min. (AdPC)
		MM(GI)		
Mechanical Characteristics	Engagement and Separation forces		Measured with corresponding connector.	Simplex plug Engagement force: 12.5 N max. Separation force: 12.5 N max. Duplex plug Engagement force: 25 N max. Separation force: 25 N max.
	Ferrule with drawal force		Extract zirconia gauge 1.249 ±0.0005 mm diameter from split sleeve.	Copper alloy split sleeve 1N to 3N Zirconia split sleeve 1N to 2.5N
	Cable retention (Straight pull)		70N tensile loads for one minute.	1) Insertion loss fluctuation after test: 0.2dB max. 2) No visible damage, dislocation of clamp or cable.
	Durability (cycles, mating/unmating)		200 times (Backplane) 500 times (Plug)	1) Insertion loss fluctuation after test: 0.2dB max. 2) No visible damage, cracks or part dislocation.
	Vibration		Frequency: 10 to 55 Hz, single amplitude of 0.75 mm, 2 hours in each of the 3 axis.	
	Shock		Acceleration of 981 m/s ² , 6 ms duration, sin half-wave waveform, 10 cycles in each of the 3 axis.	
Humidity (Temperature/ humidity- cycles)		-10°C to 65°C, humidity: 90% to 96% 10 cycles		
Environmental Characteristics	Change of Temperature		-25°C to +70°C 100 cycles	No significant corrosion.
	Dry heat		960 hours at 85°C	
	Cold		960 hours at -25°C	
	Salt mist		48 hours in a 5% concentration of salt mist	

■ Materials

Part	Material
Simplex plug housing	Synthetic resin
Spring	Steel
Ferrule	Zirconia
Simplex adapter housing	Synthetic resin
Adapter metal fittings	Stainless steel or copper alloy (Nickel plating)
Simplified receptacle housing	Synthetic resin
Simplified plug	Zirconia
Backplane connector housing	Synthetic resin
Split sleeve	Zirconia or copper alloy
Dust cap	Synthetic resin

Function diagram

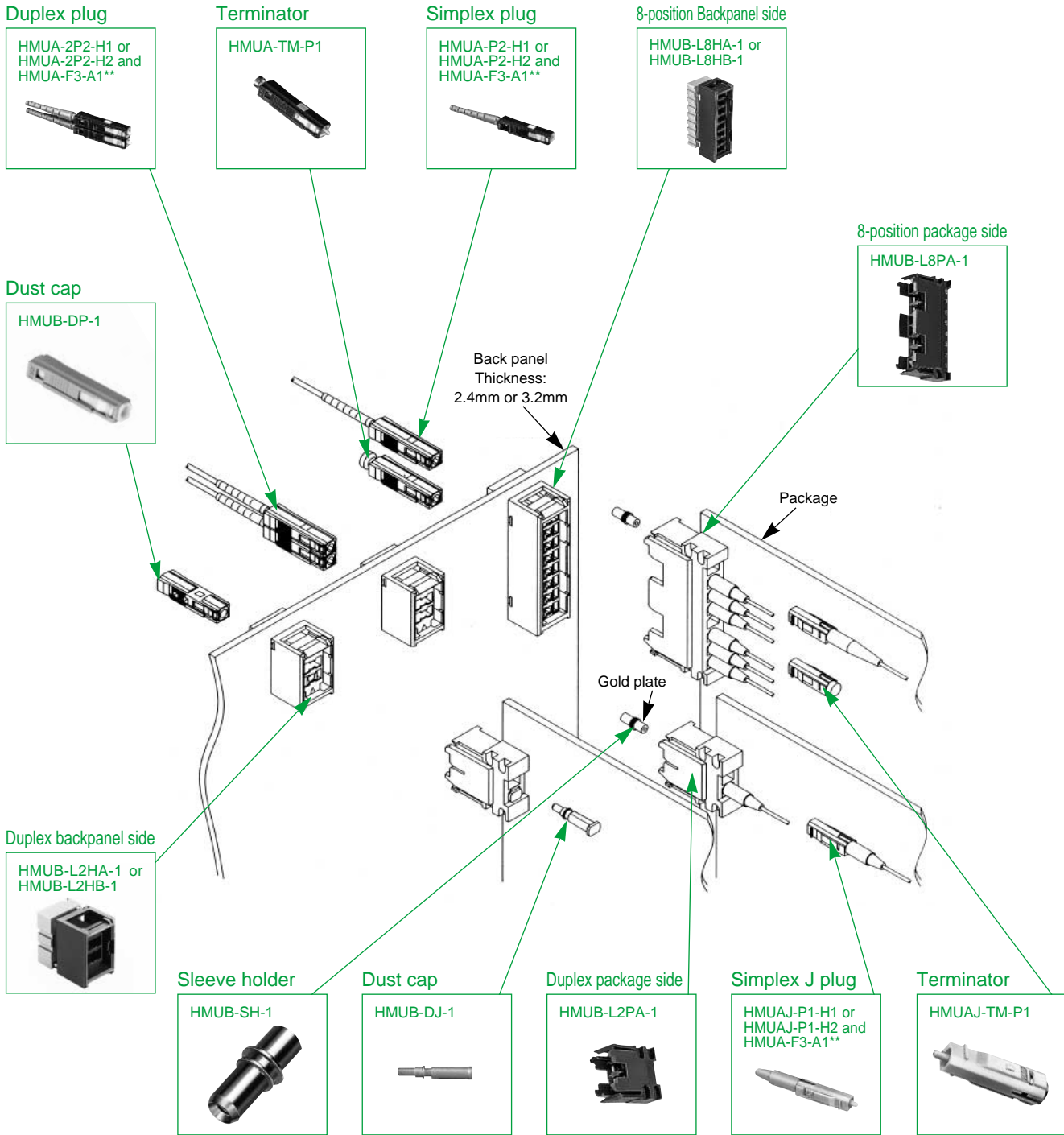

■ Plug Housings

● Simplex Plug Housing for 2mm cable

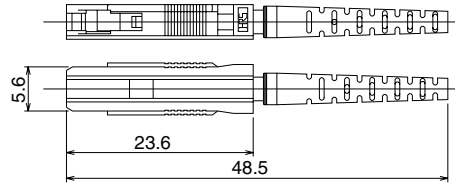
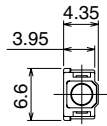

Part Number	CL No.	Boot color
HMUA-P2-H1(07)	710-0047-9-07	Blue
HMUA-P2-H2(07)	710-0001-8-07	Light purple

● Simplex Plug Housing for 0.9mm fiber

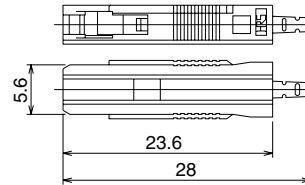
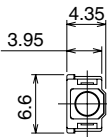

Part Number	CL No.	Boot color
HMUA-P0.9-H1(01)	710-0158-0-01	Blue
HMUA-P0.9-H2(01)	710-0159-2-01	Light purple

● Duplex Plug Housing for 2mm cable

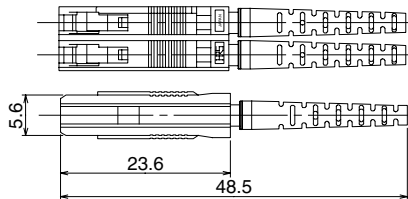
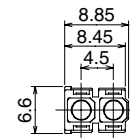

Part Number	CL No.	Boot color
HMUA-2P2-H1(07)	710-0048-1-07	Blue
HMUA-2P2-H2(07)	710-0002-0-07	Light purple

● Duplex Plug Housing for 0.9mm fiber

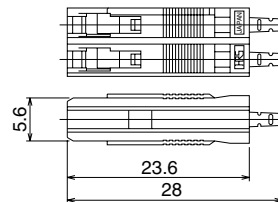
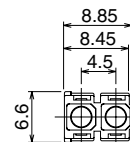

Part Number	CL No.	Boot color
HMUA-2P0.9-H1(01)	710-0162-7-01	Blue
HMUA-2P0.9-H2(01)	710-0163-0-01	Light purple

● Simplex Plug Housing for 1.1mm Cable

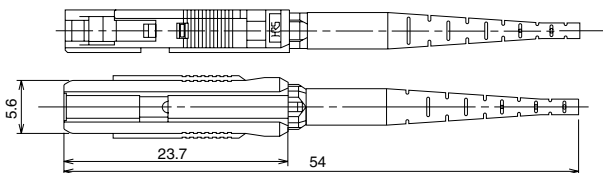
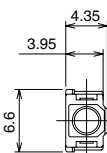

Part Number	CL No.	Boot color
HMUA-P1.1-H2	710-0133-9	Light purple

Note: Ferrules, HMUA-F3A2-A12*(10) should be needed for this plug. (see page 9) Certain assemble tools are also needed. Please contact sales representative for the details.

Ferrules

For MU plugs

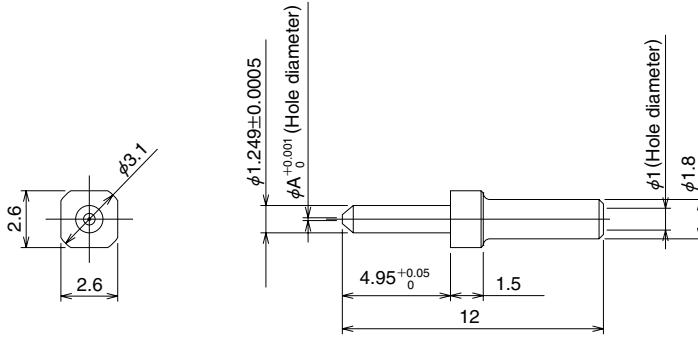
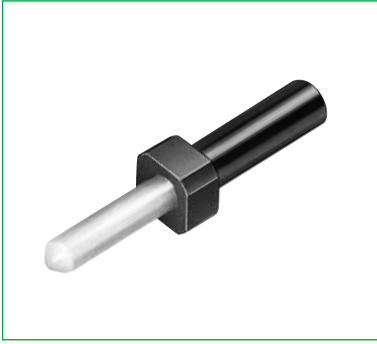

Part Number	CL No.	A dimension	Applicable Fiber cable
HMUA-F3-A125(10)	710-0024-3-10	0.125	SM,MM
HMUA-F3-A1255(10)	710-0121-0-10	0.1255	
HMUA-F3-A126(10)	710-0025-6-10	0.126	

For HMUA-P1. 1-H* plugs

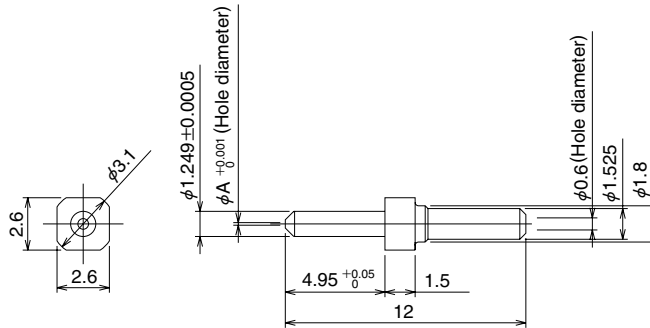

Part Number	CL No.	A dimension	Applicable Fiber cable
HMUA-F3A2-A125(10)	710-0138-2-10	0.125	SM,MM
HMUA-F3A2-A1255(10)	710-0142-0-10	0.1255	
HMUA-F3A2-A126(10)	710-0139-5-10	0.126	

Adapters

Simplex Adapter / Snap-in Panel Mounting

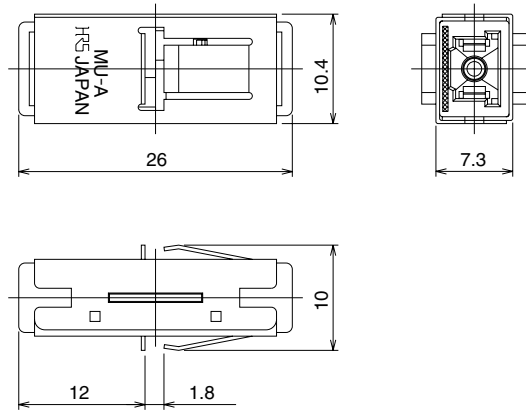

Panel Cutout

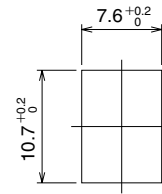

Panel thickness: 1.6mm

Part Number	CL No.	Split sleeve
HMUA-A-3	710-0103-8	Zirconia

Simplex Adapter / Screw Panel Mounting

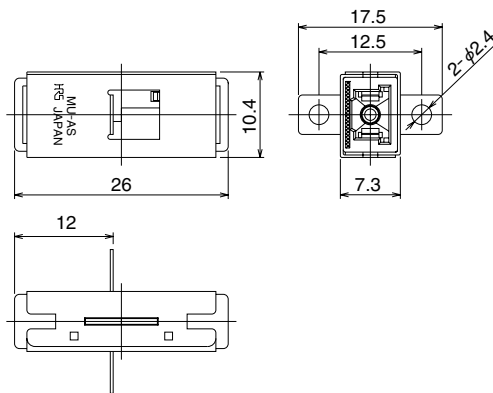

Panel Cutout

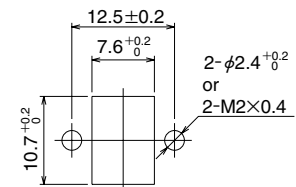

Part Number	CL No.	Split sleeve
HMUA-AS-3	710-0104-0	Zirconia

Simplex Adapter / Board Mounting

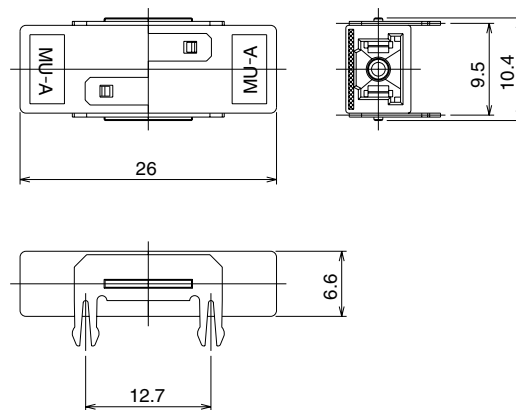

Board Mounting Pattern

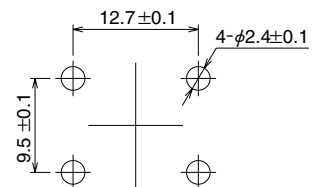

Board thickness: 1.6mm

Part Number	CL No.	Split sleeve
HMUA-AH-3	710-0105-3	Zirconia

●Duplex adapter / Snap-in Panel Mounting
4.5mm Type

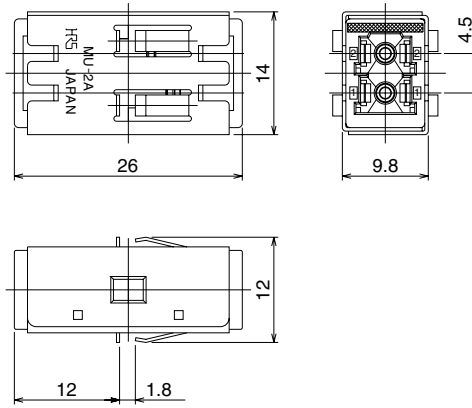
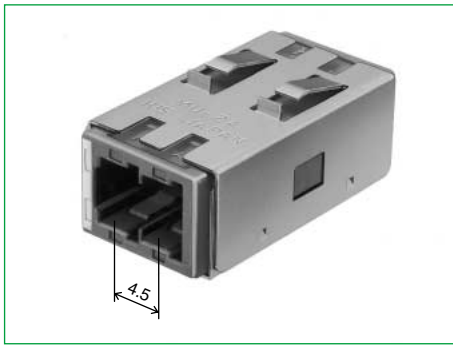

◆Panel Cutout

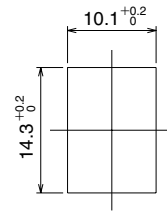

Panel thickness: 1.6mm

Part Number	CL No.	Split sleeve
HMUA-2A-4	710-0187-8	Zirconia

●Duplex Adapter / Screw Panel Mounting
6.25mm Type

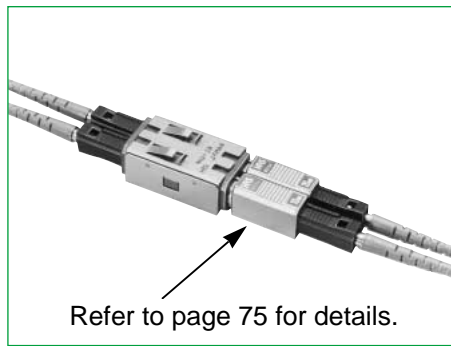

Part Number	CL No.	Split sleeve
HMUA-2AK-1	710-0196-9	Zirconia

Note: The outer dimension is the same as the above "HMUA-2A-4".

●Duplex Adapter / Screw Panel Mounting



◆Panel Cutout

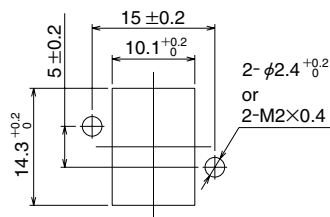

Part Number	CL No.	Split sleeve
HMUA-2AS-4	710-0188-0	Zirconia

●Duplex Adapter / Board Mounting



◆Board Mounting Pattern

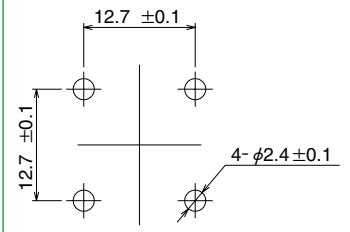

Board thickness: 1.6mm

Part Number	CL No.	Split sleeve
HMUA-2AH-4	710-0189-3	Zirconia

●8-Position Adapter / Snap-in Panel Mounting

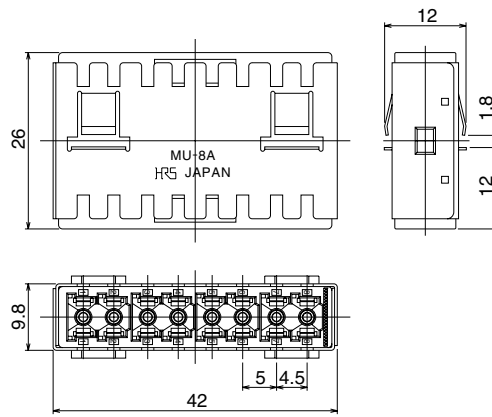

◆Panel Cutout

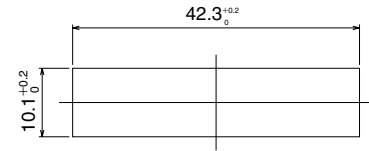

Panel thickness: 1.6mm

Part Number	CL No.	Split sleeve
HMUA-8A-3	710-0174-6	Zirconia

●8-Position Adapter / Screw Panel Mounting

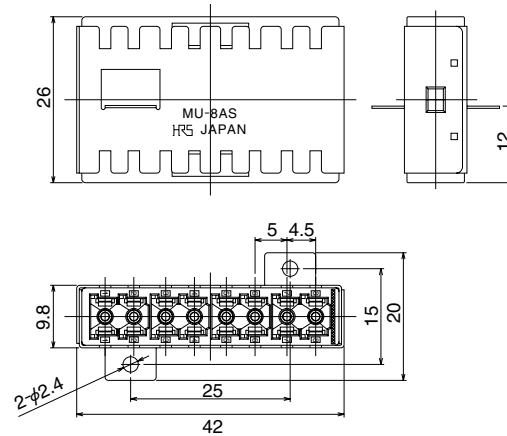

◆Panel Cutout

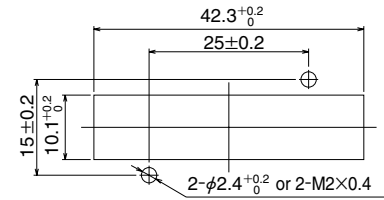

Part Number	CL No.	Split sleeve
HMUA-8AS-3	710-0175-9	Zirconia

●8-Position Adapter / Board Mounting

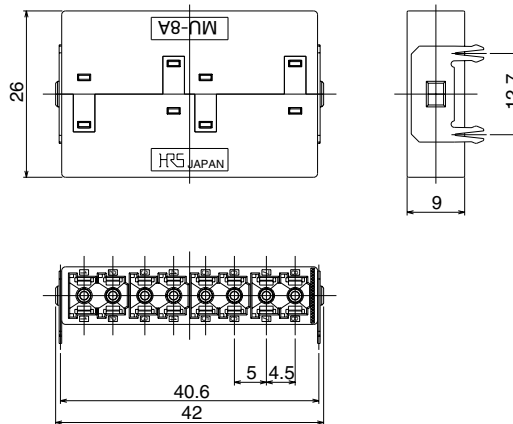

◆Board Mounting Pattern

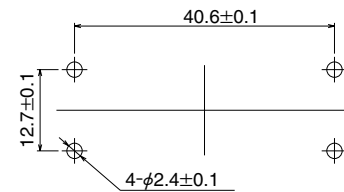

Board thickness: 1.6mm

Part Number	CL No.	Split sleeve
HMUA-8AH-3	710-0176-1	Zirconia

■ Cost effective adapters

● 8-Position Adapter / Screw Panel Mounting

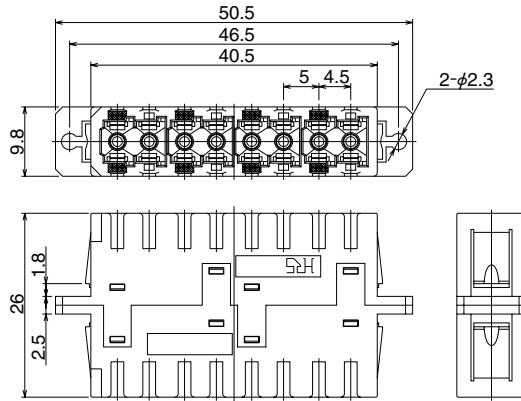

◆ Panel Cutout

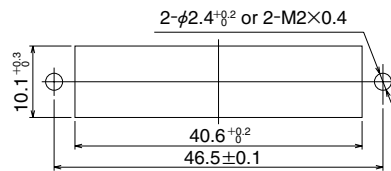

Panel thickness:1.6mm

Part Number	CL No.	Split sleeve
HMUA-8A-2	710-0155-1	Zirconia
HMUA-8A-B2	710-0119-8	Copper alloy

● 16-Position Adapter / Screw Panel Mounting

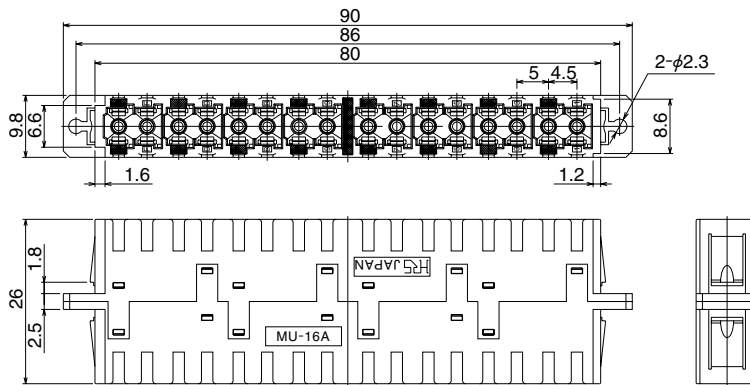

◆ Panel Cutout

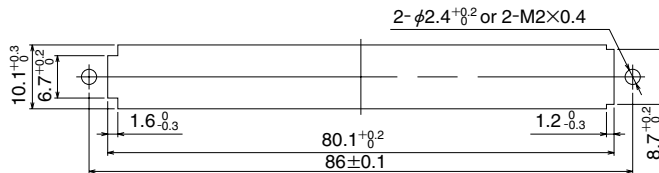

Panel thickness:1.6mm

Part Number	CL No.	Split sleeve
HMUA-16A-2	710-0143-2	Zirconia
HMUA-16A-B2	710-0113-1	Copper alloy

■Angled Adapters

●Duplex Angled Adapter / Snap-in Panel Mounting

◆Panel Cutout

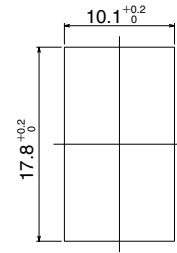
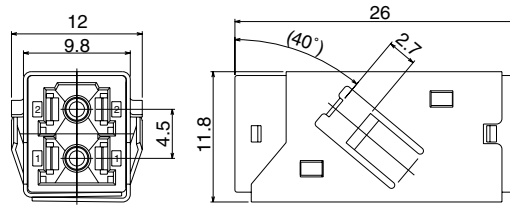

Panel thickness: 2.5mm

Part Number	CL No.	Split sleeve	Mounting Angle
HMUA-2A-40-4	710-0177-4	Zirconia	40°

●4-Position Angled Adapter / Snap-in Panel Mounting

◆Panel Cutout

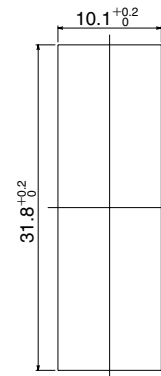
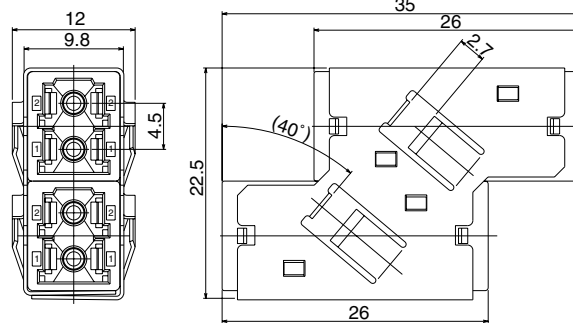

Panel thickness: 2.5mm

Part Number	CL No.	Split sleeve	Mounting Angle
HMUA-4A-40-4	710-0178-7	Zirconia	40°

■ Backpanel side Connector Housings

● Duplex Backpanel side Connector Housing

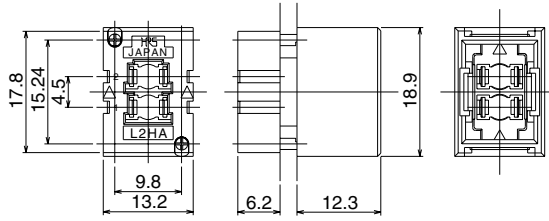

◆ Panel Cutout

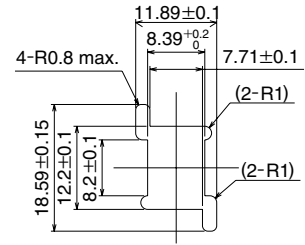

Part Number	CL No.	Panel thickness
HMUB-L2HA-1	710-0017-8	2.4mm
HMUB-L2HB-1	710-0018-0	3.2mm

Note: Screw fastening torque: 0.03Nm

● 8-Position Backpanel side Connector Housing

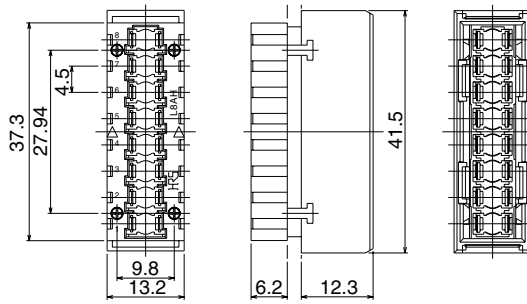

◆ Panel Cutout

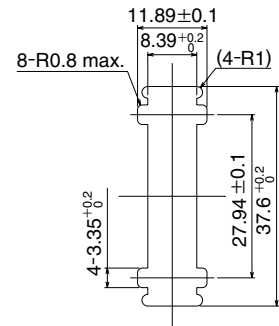

Part Number	CL No.	Panel thickness
HMUB-L8HA-1	710-0019-3	2.4mm
HMUB-L8HB-1	710-0020-2	3.2mm

Note: Screw fastening torque: 0.03Nm

Package side Connector Housings

Duplex Package side Connector Housing

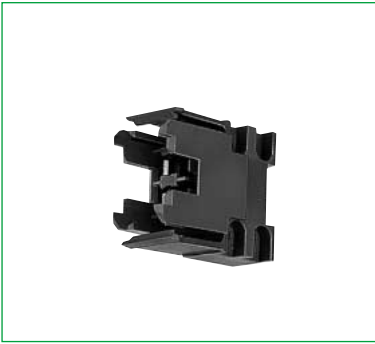

Part Number	CL No.
HMUB-L2PA-1	710-0015-2

Note : Screw fastening torque : 0.15Nm

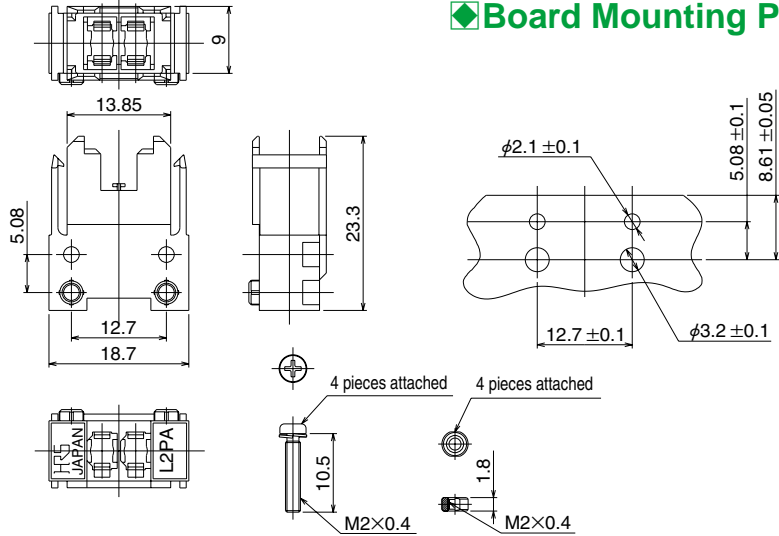

Board Mounting Pattern

8-Position Package side Connector Housing



Part Number	CL No.
HMUB-L8PA-1	710-0016-5

Note : Screw fastening torque : 0.15Nm

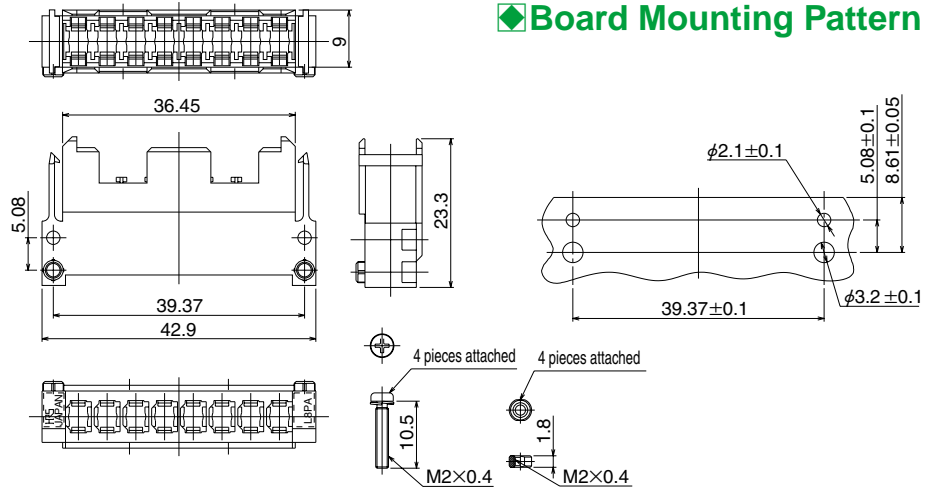

Board Mounting Pattern

Sleeve Holder



Part Number	CL No.	Split sleeve
HMUB-SH-1	710-0021-5	Zirconia

Note: This Sleeve Holder should be used for duplex and 8-position package side connector housing and J Plug Housing connector plug.

Insert the Sleeve Holder using dedicated tool #HMUB-TS-1.

The gold plated section of the Sleeve Holder should be inserted into the package side connector housing.

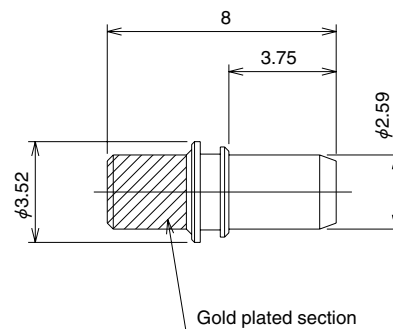

■ J Plug Housing

● Simplex J Plug Housing for 0.9mm fiber

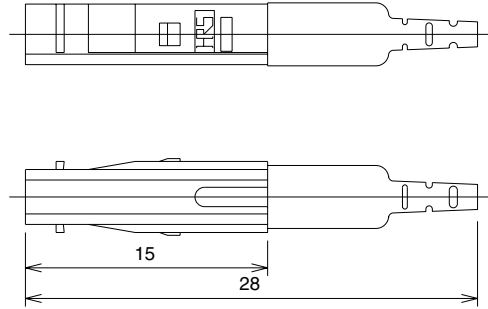
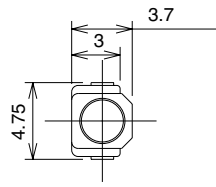

Part Number	CL No.	Boot color
HMUAJ-P0.9-H1(01)	710-0160-1-01	Blue
HMUAJ-P0.9-H2(01)	710-0161-4-01	Light purple

■ Simplified Receptacles

● Simplex Simplified Receptacle / Screw Panel Mounting

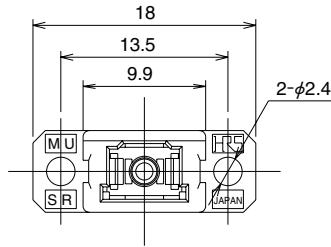
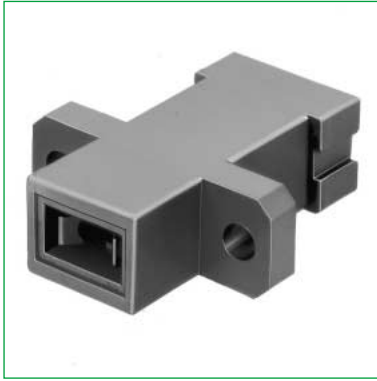

◆ Panel Cutout

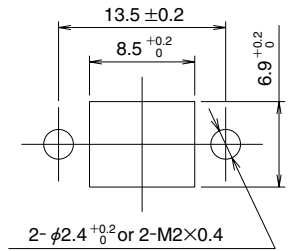

Part Number	CL No.	Split sleeve
HMUA-SR-1	710-0094-9	Zirconia
HMUA-SR-B1	710-0182-4	Copper alloy

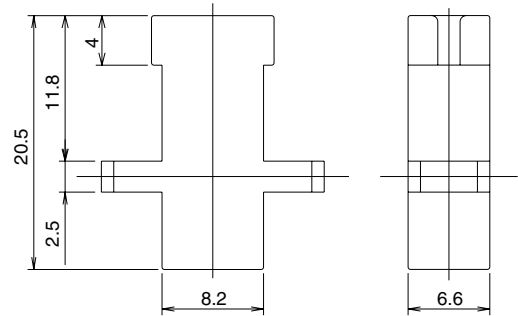

● 8-position Simplified Receptacle / Screw Panel Mounting

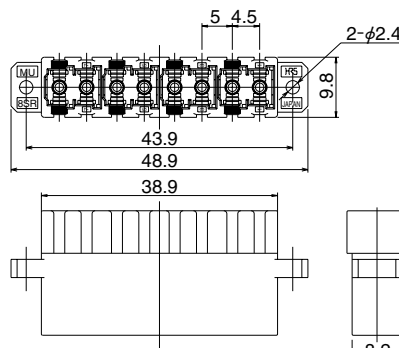

◆ Panel Cutout

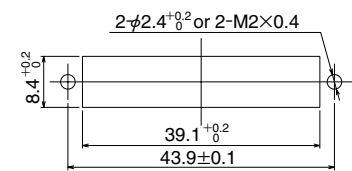

Part Number	CL No.	Split sleeve
HMUA-8SR-2	710-0172-0	Zirconia
HMUA-8SR-B2	710-0146-0	Copper alloy

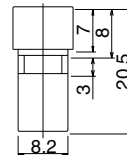

●8-position Simplified Receptacle - for extremely high density applications

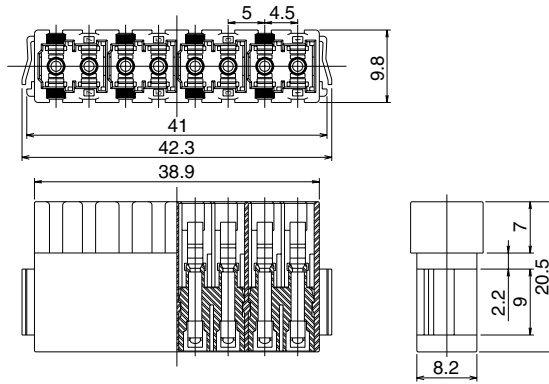

Part Number	CL No.	Split sleeve
HMUA-8SR-3	710-0168-3	Zirconia
HMUA-8SR-B3	710-0117-2	Copper alloy

●16-Position Simplified Receptacle - for extremely high density applications

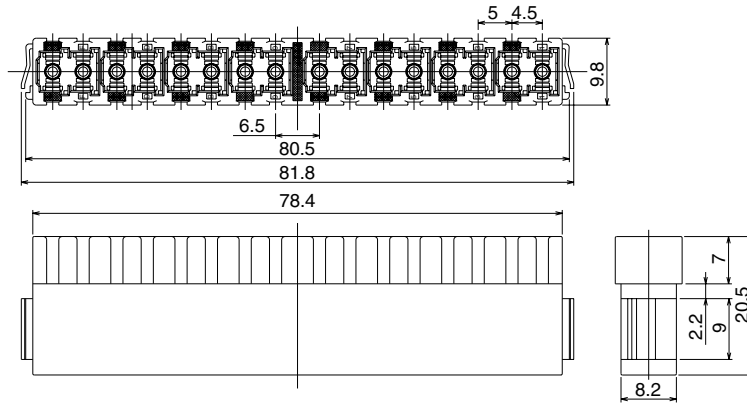
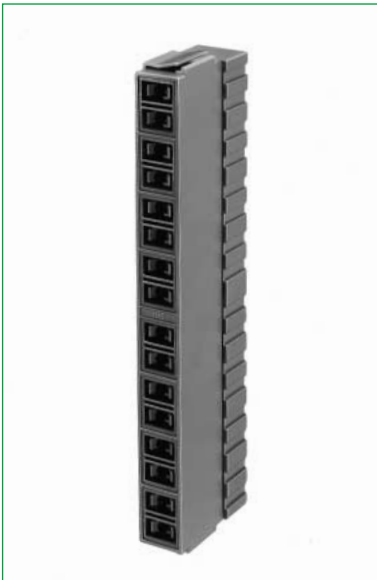

Part Number	CL No.	Split sleeve
HMUA-16SR-5	710-0173-3	Zirconia
HMUA-16SR-B5	710-0122-2	Copper alloy

◆Mounting Example

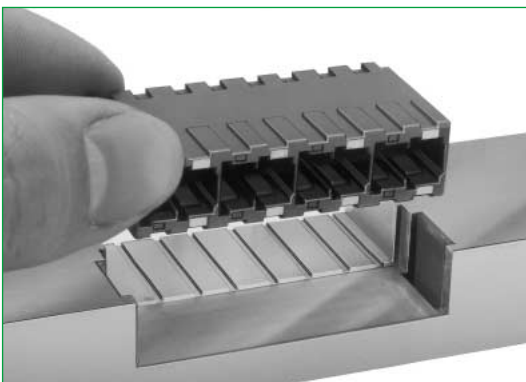

■Simplified Plug

●Simplex simplified Plug for 0.9mm fiber

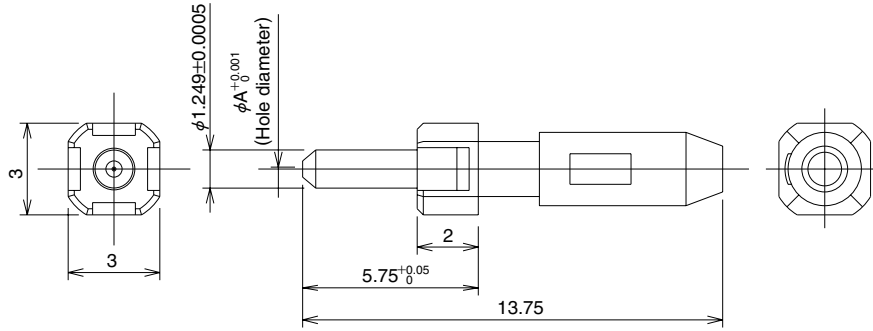

Part Number	CL No.	A dimension	Ferrule	Applicable Fiber cable
HMUA-FK-A125(04)	710-0099-2-04	0.125	Zirconia	SM, MM
HMUA-FK-A1255(04)	710-0107-9-04	0.1255		
HMUA-FK-A126(04)	710-0100-0-04	0.126		

■Split Sleeve

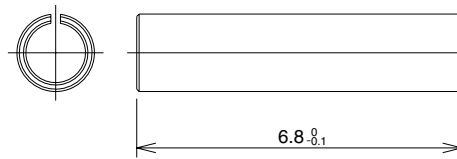

Part Number	CL No.	Split sleeve
HMUA-D(01)	710-0147-3-01	Zirconia
HMUA-SLIT-SLEEVE(01)	710-0130-0-01	Copper alloy

■Extraction Tool for Simplified Plug

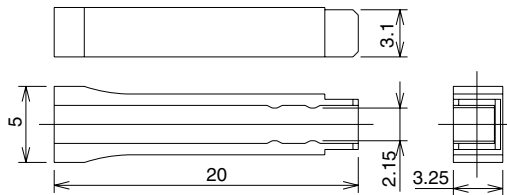

Part Number	CL No.
HMUA-FK-T3	710-0148-6

■ Attachment for Simplex Receptacle

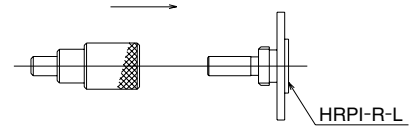
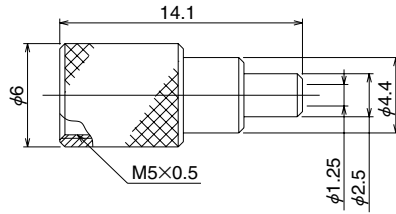

Insert straight the MU-RA type receptacle attachment and tighten the screw.

Part Number	CL No.
HMUA-RA-1	710-0014-0

For optical power (or other measurements) join the Receptacle Attachment using the tool HRPI-R-L and attach to a sensor or measuring instrument.

■ Dust Caps

● Dust Cap for Backpanel side connector housings

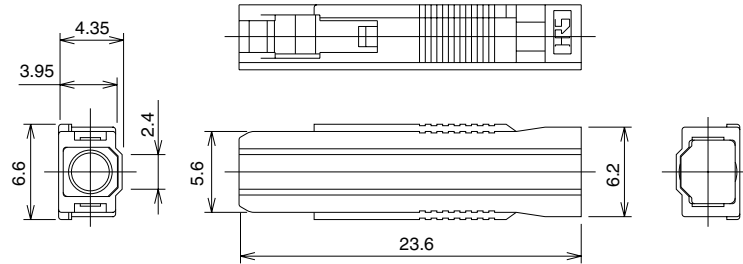

Part Number	CL No.	Applicable connector
HMUB-DP-1	710-0135-4	Back panel side housing

● Dust Cap for Package side connector housings

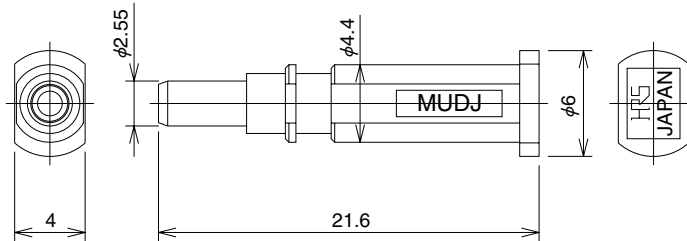
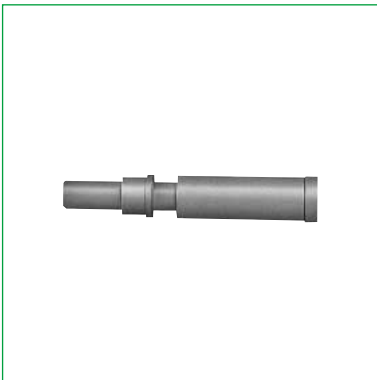

Part Number	CL No.	Applicable connector housing
HMUB-DJ-1	710-0060-7	HMUB-L2PA-1
		HMUB-L8PA-1

● Dust Cap for Adapters

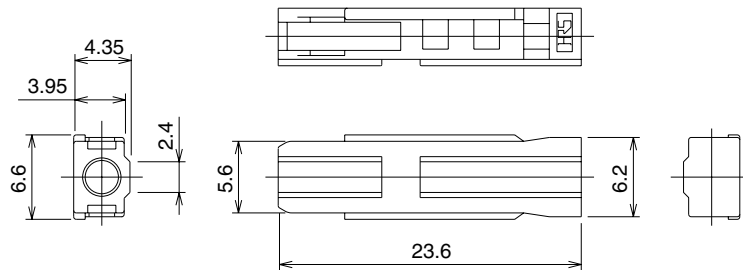

Part Number	CL No.	Applicable connector
HMUA-DP-2	710-0131-3	Adapter, simplified receptacle

■ Cable assemblies

● Simplex Plug Cable assembly

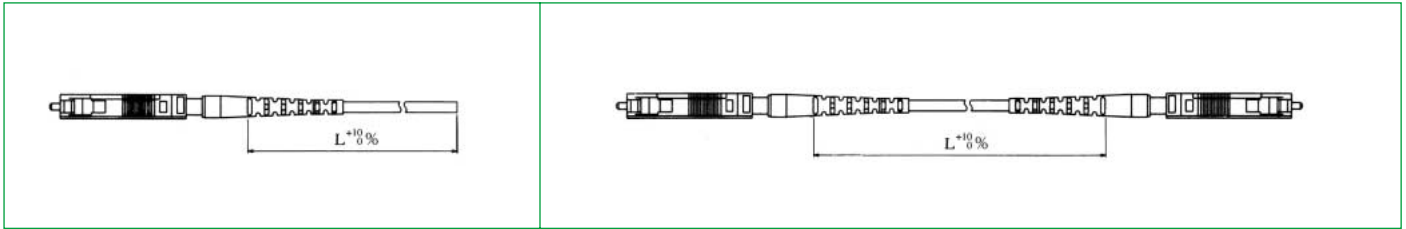

Part Number	CL No.	Connector Installation End	Applicable Fiber cable	Polishing type	Cable Diameter
HMUA-ASP1-F3Q-L	710-0028-4	One end	SM-9.5/125	AdPC	φ2mm
HMUA-ASP2-F3Q-L	710-0029-7	Both ends			
HMUA-ASP1-F3P-L	—	One end	GI-50/125		
HMUA-ASP2-F3P-L	710-0052-9	Both ends			

● Duplex Plug Cable assembly

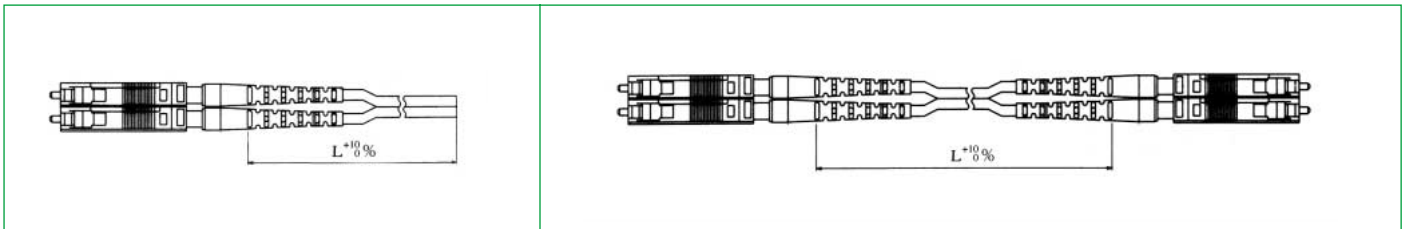

Part Number	CL No.	Connector Installation End	Applicable Fiber cable	Polishing type	Cable Diameter
HMUA-AS2P1-F3QW-L	—	One end	SM-9.5/125	AdPC	φ2mm
HMUA-AS2P2-F3QW-L	710-0062-2	Both ends			
HMUA-AS2P1-F3PW-L	—	One end	GI-50/125		
HMUA-AS2P2-F3PW-L	710-1019-9	Both ends			

Note 1: The "L" within the Part Number indicates the length of the cable illustrated the drawings. Please specify "L" in mm.

Note 2: Please contact HIROSE for other specifications.

● Simplex Plug Cable assembly

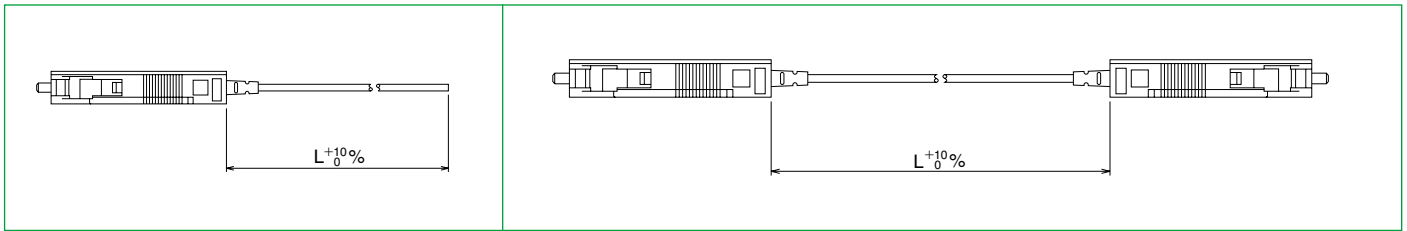

Part Number	CL No.	Connector Installation End	Applicable Fiber cable	Polishing type	Cable Diameter
HMUA-ASPH1-F3L-L	710-1051-1	One end	SM-9.5/125	AdPC	φ0.9mm
HMUA-ASPH2-F3L-L	710-1052-4	Both ends			
HMUA-ASPH1-F3M-L	710-1053-7	One end	GI-50/125		
HMUA-ASPH2-F3M-L	710-1054-0	Both ends			

● Duplex Plug cable assembly

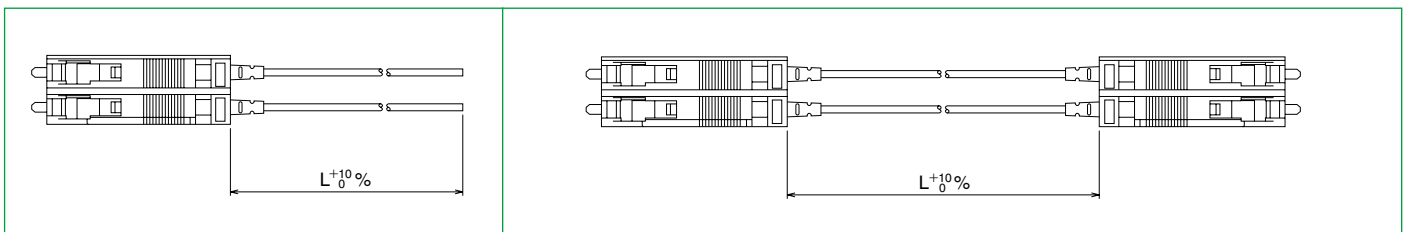

Part Number	CL No.	Connector Installation End	Applicable Fiber cable	Polishing type	Cable Diameter
HMUA-AS2PK1-F3L-L	710-1055-2	One end	SM-9.5/125	AdPC	φ0.9mm
HMUA-AS2PK2-F3L-L	710-1056-5	Both ends			
HMUA-AS2PK1-F3M-L	710-1057-8	One end	GI-50/125		
HMUA-AS2PK2-F3M-L	710-1058-0	Both ends			

Note 1: The "L" within the Part Number indicates the length of the cable illustrated the drawings. Please specify "L" in mm.

Note 2: Please contact HIROSE for other specifications.

●Simplex J Plug cable assembly

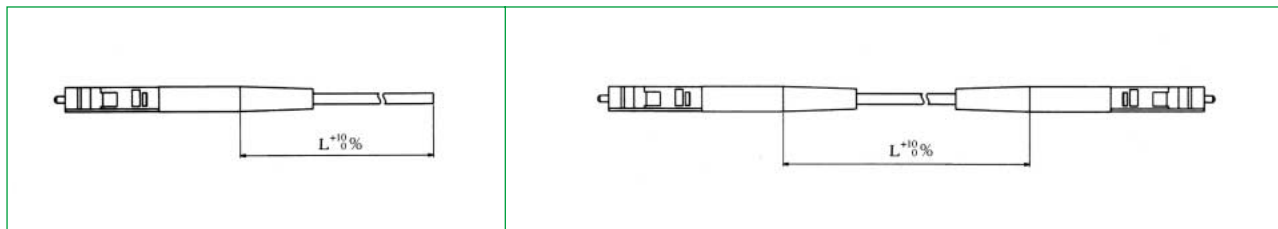

Part Number	CL No.	Connector Installation End	Applicable Fiber cable	Polishing type	Cable Diameter
HMUAJ-ASP1-F3Q-L	710-0040-0	One end	SM-9.5/125	AdPC	φ2mm
HMUAJ-ASP2-F3Q-L	710-0041-2	Both ends			
HMUAJ-ASP1-F3P-L	—	One end	GI-50/125		
HMUAJ-ASP2-F3P-L	—	Both ends			

●Simplex J Plug cable assembly

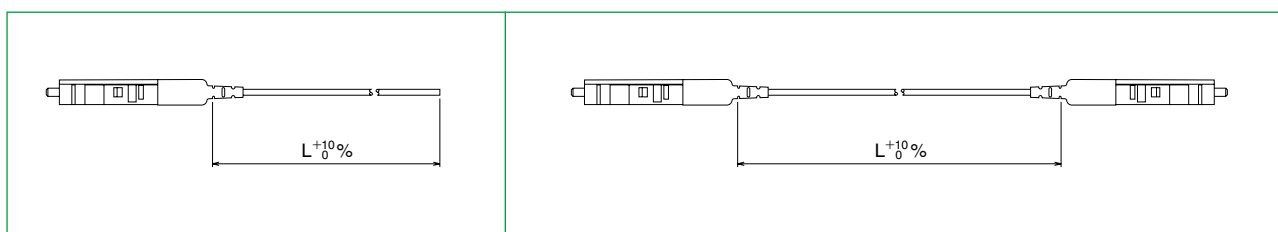

Part Number	CL No.	Connector Installation End	Applicable Fiber cable	Polishing type	Cable Diameter
HMUAJ-ASPJ1-F3L-L	710-1059-3	One end	SM-9.5/125	AdPC	φ0.9mm
HMUAJ-ASPJ2-F3L-L	710-1060-2	Both ends			
HMUAJ-ASPJ1-F3M-L	710-1061-5	One end	GI-50/125		
HMUAJ-ASPJ2-F3M-L	710-1062-8	Both ends			

Note 1: The "L" within the Part Number indicates the length of the cable illustrated the drawings. Please specify "L" in mm.

Note 2: Please contact HIROSE for other specifications.

■Tools

●Insertion / Extraction Tool for Plug



Part Number	CL No.	Color of Tip	Remarks
HMUA-TP-1	710-0074-1	Blue	For Conventional Adapters
HMUB-TP-1	710-0075-4	Brown	For MU Backplane system

●Insertion / Extraction Tool for Plug Cost effective type



Part Number	CL No.
HMU/HEMD-B	—

●Extraction Tool for J Plug



Part Number	CL No.
HMUB-TJ-1	710-0076-7

●Insertion / Extraction Tool for Sleeve Holder



Part Number	CL No.
HMUB-TS-1	710-0077-0

●Crimp Tools



Part Number	CL No.	Applicable plug housing
HMUA-TK-1	—	HMUA-P2-H2,H1
		HMUA-2P2-H2,H1



Part Number	CL No.	Applicable plug housing
HMUA-TK-2	—	HMUAJ-P2-H2,H1

●Stop Ring Insertion Tool



Part Number	CL No.	Applicable connector
HMUA.J/PR-MD	902-6019-8	MU plug housings except HMUA-P1.1-H2