

## 阅读申明

- 1.本站收集的数据手册和产品资料都来自互联网，版权归原作者所有。如读者和版权方有任何异议请及时告之，我们将妥善解决。
- 2.本站提供的中文数据手册是英文数据手册的中文翻译，其目的是协助用户阅读，该译文无法自动跟随原稿更新，同时也可能存在翻译上的不当。建议读者以英文原稿为参考以便获得更精准的信息。
- 3.本站提供的产品资料，来自厂商的技术支持或者使用者的心得体会等，其内容可能存在描述上的差异，建议读者做出适当判断。
- 4.如需与我们联系，请发邮件到marketing@iczoom.com，主题请标有“数据手册”字样。

## Read Statement

1. The datasheets and other product information on the site are all from network reference or other public materials, and the copyright belongs to the original author and original published source. If readers and copyright owners have any objections, please contact us and we will deal with it in a timely manner.
2. The Chinese datasheets provided on the website is a Chinese translation of the English datasheets. Its purpose is for reader's learning exchange only and do not involve commercial purposes. The translation cannot be automatically updated with the original manuscript, and there may also be improper translations. Readers are advised to use the English manuscript as a reference for more accurate information.
3. All product information provided on the website refer to solutions from manufacturers' technical support or users the contents may have differences in description, and readers are advised to take the original article as the standard.
4. If you have any questions, please contact us at marketing@iczoom.com and mark the subject with "Datasheets" .

## LOWER ROW

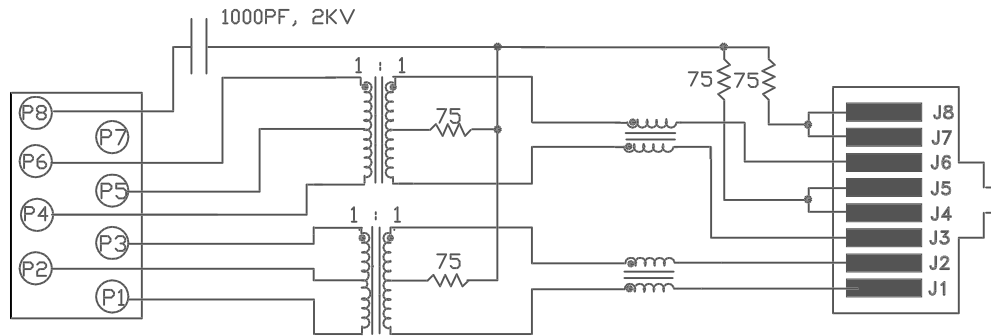

## UPPER ROW

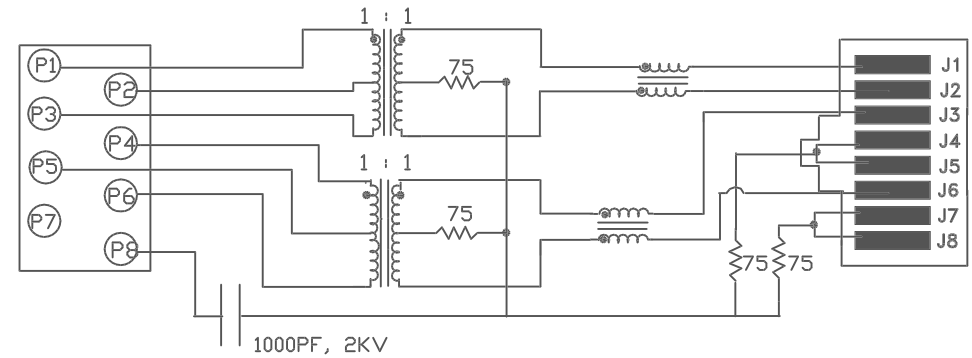

### ELECTRICAL SPECIFICATIONS:

1.0 TURNS RATIO (P1-P2-P3) : (J1-J2)	: 1CT : $1 \pm 3\%$
(P4-P5-P6) : (J3-J6)	: 1CT : $1 \pm 3\%$
2.0 INDUCTANCE (P6-P4)	: 350uH MIN. @ 0.1V , 100KHz, 8mA DC Bias
(P3-P1)	: 350uH MIN. @ 0.1V, 100KHz, 8mA DC Bias
3.0 LEAKAGE INDUCTANCE P6-P4 (WITH J6 AND J3 SHORT)	: 0.3uH MAX. @ 1MHz
P3-P1 (WITH J2 AND J1 SHORT)	: 0.3uH MAX. @ 1MHz
4.0 INTERWINDING CAPACITANCE (P6,P5,P4) TO (J6,J3)	: 25pf TYP @ 1MHz
(P3,P2,P1) TO (J2,J1)	: 25pf TYP @ 1MHz
5.0 DC RESISTANCE (J6-J3)=(J1-J2)	: 1.2 ohms Max.
(P6-P4)	: .7 ohms Max.
(P3-P1)	: .7 ohms Max.

### NOTES

1.0 PINS WITHOUT ELECTRICAL CONNECTION ARE OMITTED.

**InNet Technologies Inc.**

<http://www.innet-tech.com>

**Stewart Connector Systems**

<http://www.stewartconnector.com>

SHEET  
1 of 4

DRAWING NO. SI-30006 REV. 02

6.0 RETURN LOSS:

1MHz TO 30MHz : 18dB MIN.  
60MHz TO 80MHz : 12dB MIN.

7.0 VOLTAGE WITHSTAND:

(J1, J2) TO (P1, P2) : 1500 VAC  
(J3, J6) TO (P3,P6) : 1500 VAC

8.0 INSERTION LOSS:

100KHz TO 100MHz : 1.1 dB TYP

9.0 RISE TIME:

OUTPUT VOLTAGE = 1 V peak : 3.0 nS TYP  
PULSE WIDTH= 112nS : 3.0 nS TYP

10.0 CROSS TALK:

1MHz TO 100MHz : 40 dB TYP

11.0 COMMON TO COMMON MODE ATTENUATION:

1MHz TO 100MHz : 35dB TYP

InNet Technologies Inc.

<http://www.innet-tech.com>

Stewart Connector Systems

<http://www.stewartconnector.com>

SHEET  
2 of 4

DRAWING NO. SI-30006 REV. 02

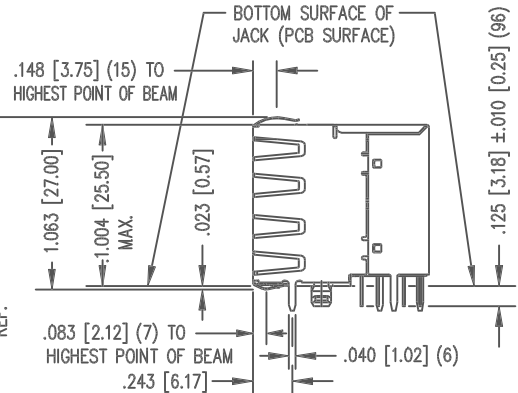
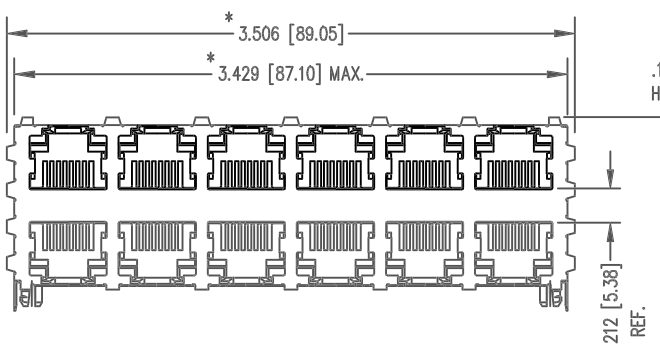
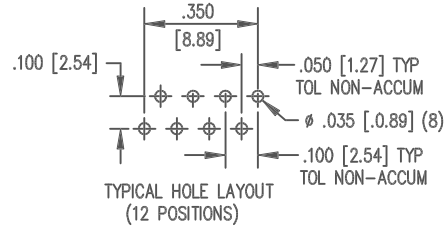
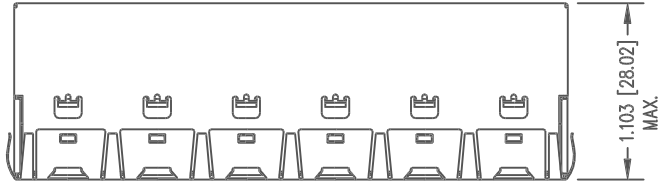

NOTES:

- TOLERANCES COMPLY WITH F.C.C. DIMENSION REQUIREMENTS.
- DIMENSIONS SHOWN WITH "\*" TO BE CENTRAL ABOUT THE CENTER LINE.
- PINS NOT ELECTRICALLY CONNECTED MAYBE OMITTED. SEE ELECTRICAL DRAWING FOR OMITTED PINS.

AVAILABLE WITH:

- STANDARD 50 MICRO-INCH SELECTIVE GOLD PLATING.

REF : SS-723-PG4

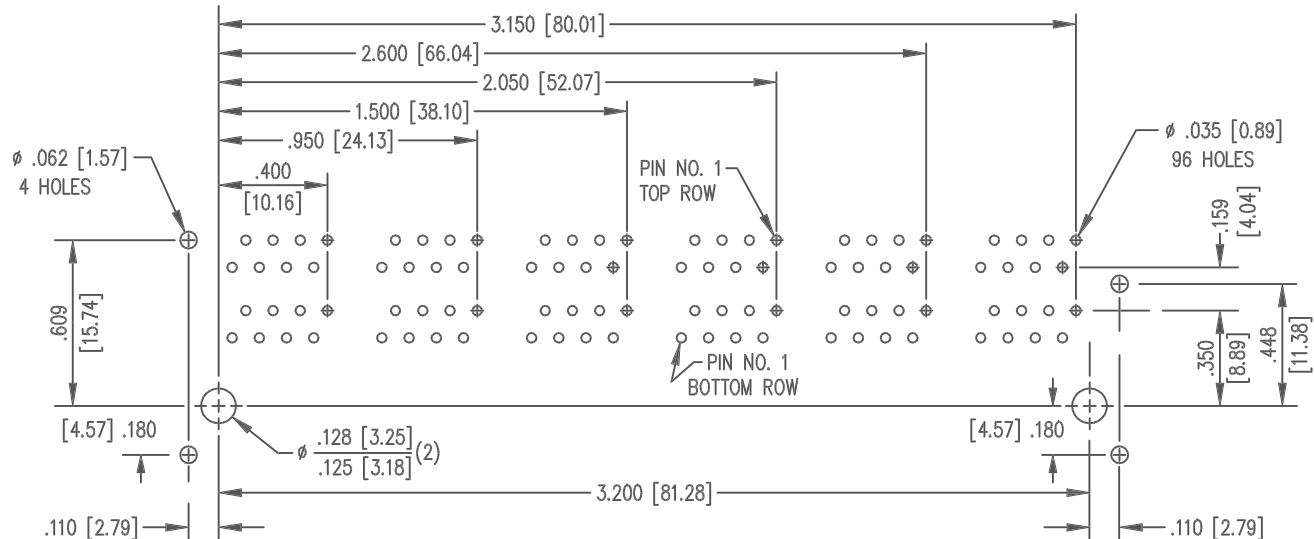

P.C.B. RECOMMENDED HOLE LAYOUT  
SEEN FROM COMPONENT SIDE  
TOLERANCE ±.003 [0.08] UNLESS OTHERWISE SPECIFIED

InNet Technologies Inc.  
<http://www.innet-tech.com>  
 Stewart Connector Systems  
<http://www.stewartconnector.com>

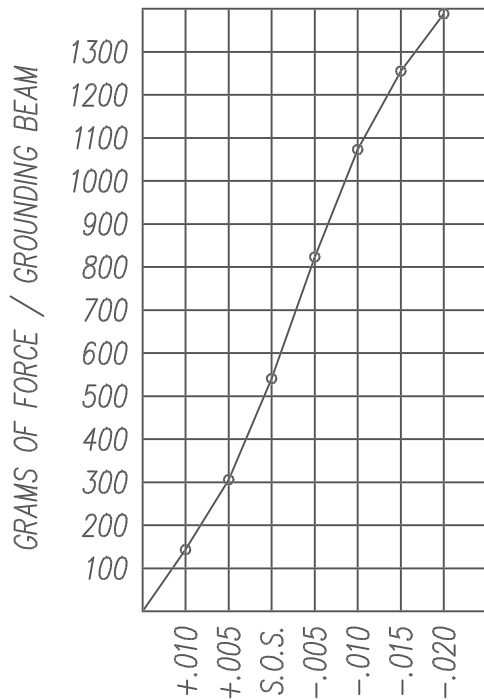

PANEL GROUNDING BEAM DEFLECTION  
TOP AND SIDE BEAMS  
S.O.S. = SUGGESTED OPENING SIZE

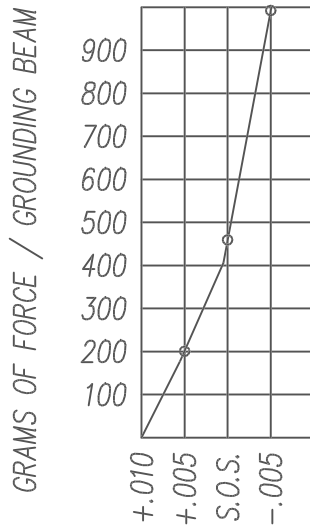

PANEL GROUNDING BEAM DEFLECTION  
BOTTOM BEAMS ONLY  
S.O.S. = SUGGESTED OPENING SIZE

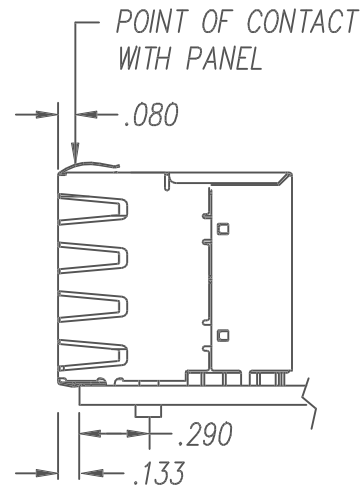

THE SUGGESTED PANEL OPENING IS INTENDED TO GIVE THE USER THE ABILITY TO HAVE REASONABLE JACK / PANEL CLEARANCES YET MAINTAIN RELIABLE GROUNDING CAPABILITY. THESE VARIABLES CAN BE ADJUSTED IN EITHER DIRECTION BUT MAY CARRY SOME CONSEQUENCES IN THE FORM OF LOWER MATING FORCES OR TIGHTER ASSEMBLY TOLERANCES. FORCE VALUES ON THE GRAPH(S) ARE GENERAL AVERAGES TAKEN AT A POINT OF CONTACT SHOWN ABOVE. THE SUGGESTED PANEL OPENING INCLUDES APPROXIMATELY .020 CLEARANCE ON THE TOP AND SIDES, WITH .015 CLEARANCE ON THE BOTTOM.

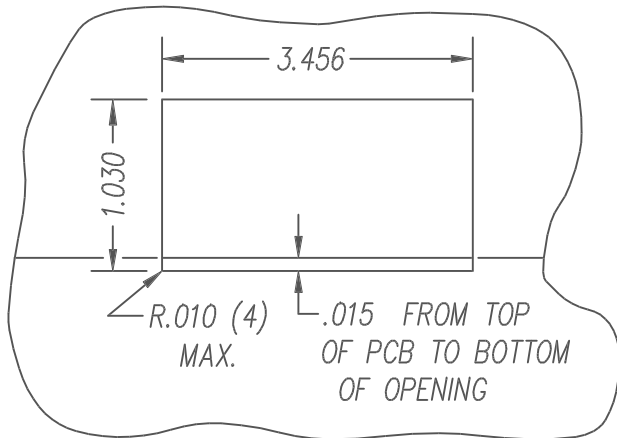

SUGGESTED PANEL OPENING  
(N.T.S.)

InNet Technologies Inc.  
<http://www.innet-tech.com>  
Stewart Connector Systems  
<http://www.stewartconnector.com>

SHEET  
4 OF 4

DRAWING NO. SI-30006 REV. 03