

阅读申明

- 1.本站收集的数据手册和产品资料都来自互联网，版权归原作者所有。如读者和版权方有任何异议请及时告之，我们将妥善解决。
- 2.本站提供的中文数据手册是英文数据手册的中文翻译，其目的是协助用户阅读，该译文无法自动跟随原稿更新，同时也可能存在翻译上的不当。建议读者以英文原稿为参考以便获得更精准的信息。
- 3.本站提供的产品资料，来自厂商的技术支持或者使用者的心得体会等，其内容可能存在描述上的差异，建议读者做出适当判断。
- 4.如需与我们联系，请发邮件到marketing@iczoom.com，主题请标有“数据手册”字样。

Read Statement

1. The datasheets and other product information on the site are all from network reference or other public materials, and the copyright belongs to the original author and original published source. If readers and copyright owners have any objections, please contact us and we will deal with it in a timely manner.
2. The Chinese datasheets provided on the website is a Chinese translation of the English datasheets. Its purpose is for reader's learning exchange only and do not involve commercial purposes. The translation cannot be automatically updated with the original manuscript, and there may also be improper translations. Readers are advised to use the English manuscript as a reference for more accurate information.
3. All product information provided on the website refer to solutions from manufacturers' technical support or users the contents may have differences in description, and readers are advised to take the original article as the standard.
4. If you have any questions, please contact us at marketing@iczoom.com and mark the subject with "Datasheets" .

1mm Pitch SMT Board to Board Connector(Standard Interface Connector Compliant with VESA FPDI-1)

DF9 Series

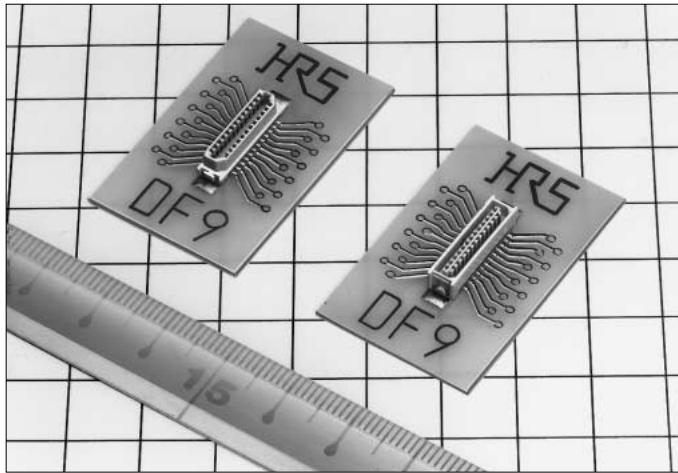

■Features

1. Compliant with the VESA FPDI-1 Standard Interface Connector

The 31 and 41 contact connectors comply with the standard connector specification for the flat panel display interface, which U.S VESA. has selected as FPDI-1.

VESA: Video Electronics Standards Association

FPDI-1: Flat Panel Display Interface

2. Perfect Mis-insertion Prevention

The mating area is designed in a trapezoidal structure, and perfectly prevents the mis-insertion despite the miniature size.

3. Equipped with Easy Lock Mechanism

The easy lock mechanism assures the firm insertion and extraction properties as well as the insertion/extraction feeling touch.

4. Smooth Insertion and Extraction Feeling

The contact is constructed without the material fragile surface in the contact portion, and provides a smooth insertion and use feeling.

5. Setting Two Type Platings as Standard

Two type platings, tin plating and gold plating, are prepared, and either appropriate plating can be selected under cost and use conditions.

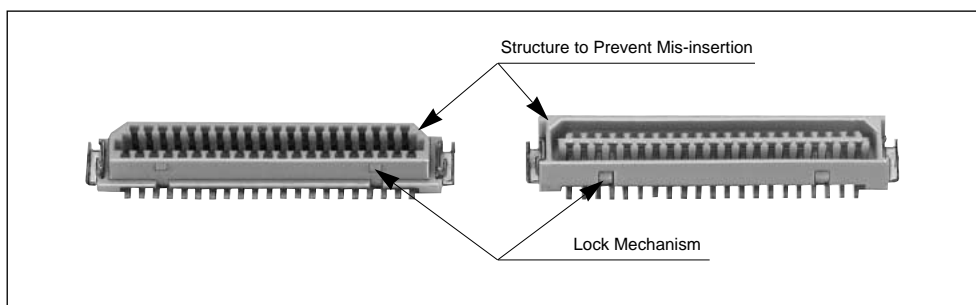

■Applications

LCD (Liquid Crystal Display), Mobile phone, Note PC

■Product Specifications

Rating	Current rating 0.5A	Operating Temperature Range -45 to +125°C (Note 1)	Storage Temperature Range -10 to +60°C (Note 2)
	Voltage rating 150V AC	Operating Humidity Range 40 to 80%	Storage Humidity Range 40 to 70%

Item	specification	Condition
1. Insulation Resistance	500M ohms min.	100V DC
2. Withstanding voltage	No flashover or insulation breakdown.	250V AC/1 minute
3. Contact Resistance	50m ohms max.	100mA
4. Vibration	No electrical discontinuity of 1μs or more	Frequency: 10 to 55 Hz, single amplitude of 0.75 mm, 2 hours in each of the 3 directions.
5. Humidity (Steady state)	Contact resistance: 50m ohms max. Insulation resistance: 500M ohms min.	96 hours at temperature of 40°C and humidity of 90% to 95%
6. Temperature Cycle	Contact resistance: 50m ohms max. Insulation resistance: 500M ohms min.	(-55°C: 30 minutes 5 to 35°C: 10 minutes 85°C: 30 minutes 5 to 35°C: 10 minutes) 5 cycles
7. Operating Life	Contact resistance: 50m ohms max:	Tin plating: 30 cycles Gold plating: 100 cycles
8. Resistance to Soldering heat	No deformation of components affecting performance.	Reflow: At the recommended temperature profile
		Manual soldering: 300°C for 3 seconds

Note 1: Includes temperature rise caused by current flow.

Note 2: The term "storage" refers to products stored for long period of time prior to mounting and use. Operating Temperature Range and Humidity range covers non conducting condition of installed connectors in storage, shipment or during transportation.

■Material

Product	Part	Material	Finish	Remarks
Receptacle/Header	Insulator	Polyamide	Beige	UL94V-0
	Contact	Phosphor copper	Tin plating or gold plating	————
	Metal fitting	Brass	Tin plating	————

Note: The gold plated product contact area is plated with gold, and lead plated with tin-lead.

■ Ordering Information

●Receptacle/Header

DF9 **#** - ***** **S** - **1** **V** (******)
① ② ③ ④ ⑤ ⑥ ⑦

① Series Name : DF9 ② Type Symbol <table border="1" style="margin-left: 20px;"> <thead> <tr> <th>Symbol</th> <th>Fitting</th> <th>Boss</th> </tr> </thead> <tbody> <tr> <td>None</td> <td style="text-align: center;">○</td> <td style="text-align: center;">○</td> </tr> <tr> <td>A</td> <td style="text-align: center;">×</td> <td style="text-align: center;">○</td> </tr> <tr> <td>B</td> <td style="text-align: center;">○</td> <td style="text-align: center;">×</td> </tr> <tr> <td>C</td> <td style="text-align: center;">×</td> <td style="text-align: center;">×</td> </tr> </tbody> </table>	Symbol	Fitting	Boss	None	○	○	A	×	○	B	○	×	C	×	×	④ Connector Type S: Receptacle P: Header ⑤ Contact Pitch : 1mm ⑥ Contact Type V: Straight SMT ⑦ Contact Surface Finish/Packaging Type (20): Tin plating, tube packaging (54): Gold plating, tube packaging (22): Tin plating, embossed tape packaging (59): Gold plating, embossed tape packaging
Symbol	Fitting	Boss														
None	○	○														
A	×	○														
B	○	×														
C	×	×														
③ Number of Contacts 9 to 25,31,41,51																

*Refer to page A284 for the bottom entry type (DF9L).

■Receptacle With metal fitting

With boss

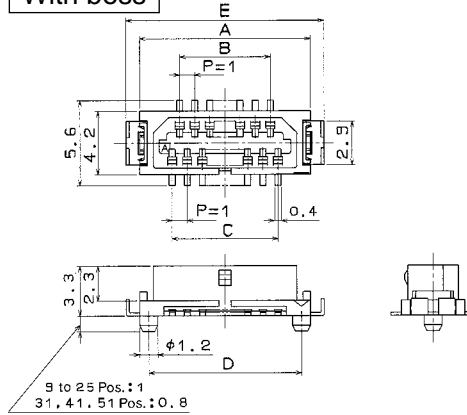
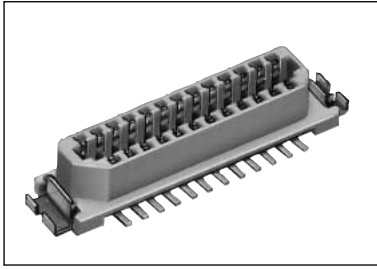

[Specific No.] - **, (**)
 (20) : Tin plating, tube packaging
 (54) : Gold plating, tube packaging
 (22) : Tin plating, embossed tape packaging
 (59) : Gold plating, embossed tape packaging

Unit: mm

Part Number	CL No.	Number of Contacts	A	B	C	D	E	Tube Packaging Quantity	Spec. (20)	Spec. (54)	Spec. (22)	Spec. (59)	Remarks
DF9- 9S-1V (**)	540-0054-0-**-	9	8.3	3	4	7.1	10.1	46	○	○	○	○	With metal fitting With boss With pick and place tape for embossed tape packaging.
DF9-11S-1V (**)	540-0055-2-**-	11	9.3	4	5	8.1	11.1	42	○	○	○	○	
DF9-13S-1V (**)	540-0056-5-**-	13	10.3	5	6	9.1	12.1	39	○	○	○	○	
DF9-15S-1V (**)	540-0057-8-**-	15	11.3	6	7	10.1	13.1	36	○	○	○	○	
DF9-17S-1V (**)	540-0058-0-**-	17	12.3	7	8	11.1	14.1	33	○	○	○	○	
DF9-19S-1V (**)	540-0059-3-**-	19	13.3	8	9	12.1	15.1	31	○	○	○	○	
DF9-21S-1V (**)	540-0060-2-**-	21	14.3	9	10	13.1	16.1	29	○	○	○	○	
DF9-23S-1V (**)	540-0061-5-**-	23	15.3	10	11	14.1	17.1	28	○	○	○	—	
DF9-25S-1V (**)	540-0062-8-**-	25	16.3	11	12	15.1	18.1	26	○	○	○	○	
DF9-31S-1V (**)	540-0063-0-**-	31	19.3	14	15	18.1	21.1	22	○	○	○	○	
DF9-41S-1V (**)	540-0213-1-**-	41	24.3	19	20	23.1	26.1	18	○	○	○	○	
DF9-51S-1V (**)	540-0064-3-**-	51	29.3	24	25	28.1	31.1	15	—	○	—	○	

Note 1 : Please order the tube packaging product by multiplying the packaging quantity (pcs.).

Note 2 : Please order the embossed tape packaging product per reel. (1000 pcs. per reel)

Note 3 : — are not available. Regarding blank, please contact Hirose sales representative.

■Receptacle Without metal fitting

With boss

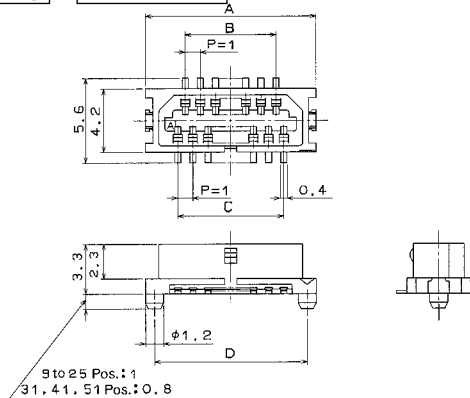
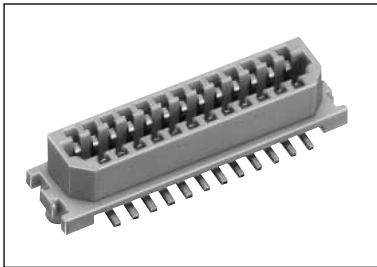

[Specific No.] - **, (**)
 (20): Tin plating, tube packaging
 (54): Gold plating, embossed tape packaging
 (22): Tin plating, tube packaging
 (59): Gold plating, embossed tape packaging

Unit: mm

Part Number	CL No.	Number of Contacts	A	B	C	D	E	Tube Package Quantity, Piece/Pack	Spec. (20)	Spec. (54)	Spec. (22)	Spec. (59)	Remarks
DF9A- 9S-1V (**)	540-0004-1-**-	9	8.3	3	4	7.1	—	59	○	—	○	—	Without metal fitting With boss With pick and place tape for embossed tape packaging.
DF9A-11S-1V (**)	540-0005-4-**-	11	9.3	4	5	8.1	—	52	○	—	○	—	
DF9A-13S-1V (**)	540-0006-7-**-	13	10.3	5	6	9.1	—	47	○	—	○	○	
DF9A-15S-1V (**)	540-0007-0-**-	15	11.3	6	7	10.1	—	43	○	○	○	○	
DF9A-17S-1V (**)	540-0008-2-**-	17	12.3	7	8	11.1	—	39	○	—	—	—	
DF9A-19S-1V (**)	540-0009-5-**-	19	13.3	8	9	12.1	—	36	○	—	○	○	
DF9A-21S-1V (**)	540-0010-4-**-	21	14.3	9	10	13.1	—	34	○	—	○	○	
DF9A-23S-1V (**)	540-0011-7-**-	23	15.3	10	11	14.1	—	32	○	—	—	—	
DF9A-25S-1V (**)	540-0012-0-**-	25	16.3	11	12	15.1	—	30	○	—	○	○	
DF9A-31S-1V (**)	540-0013-2-**-	31	19.3	14	15	18.1	—	24	○	○	○	○	
DF9A-41S-1V (**)	540-0222-2-**-	41	24.3	19	20	23.1	—	20	○	—	○	○	
DF9A-51S-1V (**)	540-0014-5-**-	51	29.3	24	25	28.1	—	16	—	○	—	○	

Note 1 : Please order the tube packaging product by multiplying the packaging quantity (pcs.).

Note 2 : Please order the emboss packaging product per reel. (1000 pcs. per reel)

Note 3 : — are not available. Regarding blank, please contact Hirose sales representative.

■Receptacle With metal fitting Without boss

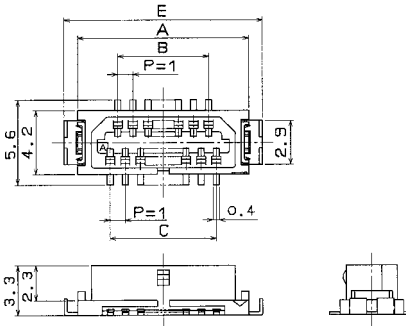
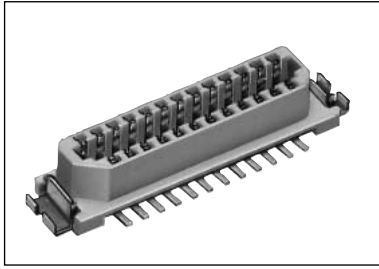

[Specific No.] – **, (**)
 (20): Tin plating, tube packaging
 (54): Gold plating, embossed tape packaging
 (22): Tin plating, tube packaging
 (59): Gold plating, embossed tape packaging

Unit: mm

Part Number	CL No.	Number of Contacts	A	B	C	D	E	Tube Package Quantity, Pcs./pack	Spec. (20)	Spec. (54)	Spec. (22)	Spec. (59)	Remarks
DF9B-9S-1V (**)	540-0125-6-**-	9	8.3	3	4	—	10.1	46	—	○	○	○	With metal fitting Without boss
DF9B-11S-1V (**)	540-0126-9-**-	11	9.3	4	5	—	11.1	42	○	—	○	—	
DF9B-13S-1V (**)	540-0127-1-**-	13	10.3	5	6	—	12.1	39	○	—	○	—	With pick and place tape for embossed tape packaging.
DF9B-15S-1V (**)	540-0128-4-**-	15	11.3	6	7	—	13.1	36	○	—	○	—	
DF9B-17S-1V (**)	540-0129-7-**-	17	12.3	7	8	—	14.1	33	—	—	—	○	
DF9B-19S-1V (**)	540-0247-3-**-	19	13.3	8	9	—	15.1	31	—	○	—	○	
DF9B-21S-1V (**)	540-0131-9-**-	21	14.3	9	10	—	16.1	29	○	—	○	—	
DF9B-23S-1V (**)	540-0132-1-**-	23	15.3	10	11	—	17.1	28	○	—	○	—	
DF9B-25S-1V (**)	540-0133-4-**-	25	16.3	11	12	—	18.1	26	○	—	○	—	
DF9B-31S-1V (**)	540-0143-8-**-	31	19.3	14	15	—	21.1	22	○	○	○	○	
DF9B-41S-1V (**)	540-0216-0-**-	41	24.3	19	20	—	26.1	18	○	○	○	—	
DF9B-51S-1V (**)	540-0145-3-**-	51	29.3	24	25	—	31.1	15	—	○	—	○	

Note 1 : Please order the tube packaging product by multiplying the packaging quantity (pcs.).

Note 2 : Please order the embossed tape packaging product per reel. (1000 pcs. per reel)

Note 3 : — are not available. Regarding blank, please contact Hirose sales representative.

■Header With metal fitting With boss

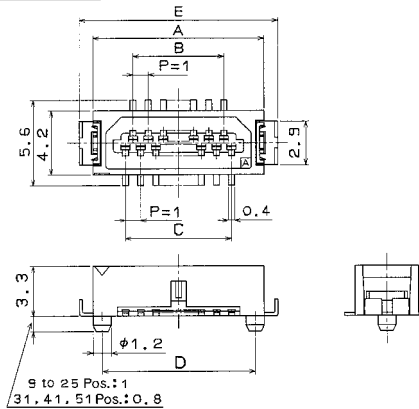
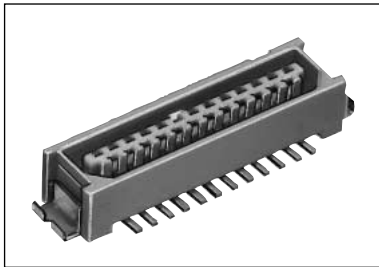

[Specific No.] – **, (**)
 (20): Tin plating, tube packaging
 (54): Gold plating, embossed tape packaging
 (22): Tin plating, tube packaging
 (59): Gold plating, embossed tape packaging

Unit: mm

Part Number	CL No.	Number of Contacts	A	B	C	D	E	Tube Package Quantity, Piece/Pack	Spec. (20)	Spec. (54)	Spec. (22)	Spec. (59)	Remarks
DF9-09P-1V (**)	540-0066-9-**-	9	8.3	3	4	7.1	10.1	46	○	○	○	○	With metal fitting With boss
DF9-11P-1V (**)	540-0067-1-**-	11	9.3	4	5	8.1	11.1	42	○	○	○	○	
DF9-13P-1V (**)	540-0068-4-**-	13	10.3	5	6	9.1	12.1	39	○	○	○	○	With pick and place tape for embossed tape packaging.
DF9-15P-1V (**)	540-0069-7-**-	15	11.3	6	7	10.1	13.1	36	○	○	○	○	
DF9-17P-1V (**)	540-0070-6-**-	17	12.3	7	8	11.1	14.1	33	○	○	○	○	
DF9-19P-1V (**)	540-0071-9-**-	19	13.3	8	9	12.1	15.1	31	○	○	○	○	
DF9-21P-1V (**)	540-0072-1-**-	21	14.3	9	10	13.1	16.1	29	○	○	○	○	
DF9-23P-1V (**)	540-0073-4-**-	23	15.3	10	11	14.1	17.1	28	○	○	—	—	
DF9-25P-1V (**)	540-0074-7-**-	25	16.3	11	12	15.1	18.1	26	○	○	○	○	
DF9-31P-1V (**)	540-0075-0-**-	31	19.3	14	15	18.1	21.1	22	○	○	○	○	
DF9-41P-1V (**)	540-0214-4-**-	41	24.3	19	20	23.1	26.1	18	○	○	○	○	
DF9-51P-1V (**)	540-0088-1-**-	51	29.3	24	25	28.1	31.1	15	—	○	—	○	

Note 1 : Please order the tube packaging product by multiplying the packaging quantity (pcs.).

Note 2 : Please order the emboss packaging product per reel. (1000 pcs. per reel)

Note 3 : — are not available. Regarding blank, please contact Hirose sales representative.

Header Without metal fitting

With boss

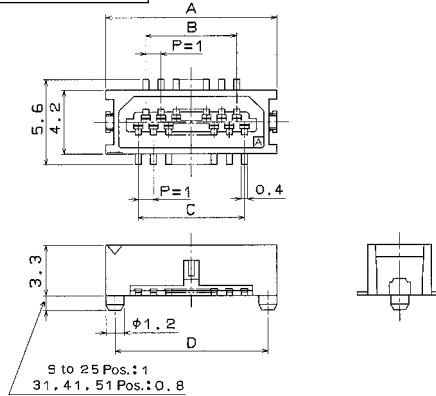
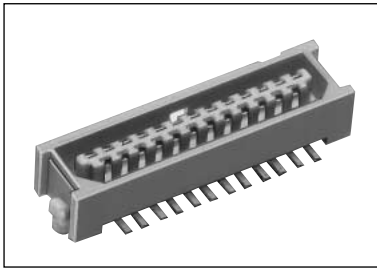

[Specific No.] - **, (**)
 (20) : Tin plating, tube packaging
 (54) : Gold plating, tube packaging
 (22) : Tin plating, embossed tape packaging
 (59) : Gold plating, embossed tape packaging

Unit: mm

Part Number	CL No.	Number of Contacts	A	B	C	D	E	Tube Package Quantity, Pcs./pack	Spec. (20)	Spec. (54)	Spec. (22)	Spec. (59)	Remarks
DF9A- 9P-1V (**)	540-0016-0-**-	9	8.3	3	4	7.1	-	59	○	-	○	-	Without metal fitting With boss With pick and place tape for embossed tape packaging.
DF9A-11P-1V (**)	540-0017-3-**-	11	9.3	4	5	8.1	-	52	○	○	○	-	
DF9A-13P-1V (**)	540-0018-6-**-	13	10.3	5	6	9.1	-	47	○	-	○	○	
DF9A-15P-1V (**)	540-0019-9-**-	15	11.3	6	7	10.1	-	43	○	○	○	○	
DF9A-17P-1V (**)	540-0020-8-**-	17	12.3	7	8	11.1	-	39	○	-	-	○	
DF9A-19P-1V (**)	540-0021-0-**-	19	13.3	8	9	12.1	-	36	○	-	○	-	
DF9A-21P-1V (**)	540-0022-3-**-	21	14.3	9	10	13.1	-	34	○	-	○	○	
DF9A-23P-1V (**)	540-0023-6-**-	23	15.3	10	11	14.1	-	32	○	-	-	-	
DF9A-25P-1V (**)	540-0024-9-**-	25	16.3	11	12	15.1	-	30	○	○	○	○	
DF9A-31P-1V (**)	540-0025-1-**-	31	19.3	14	15	18.1	-	24	○	○	○	○	
DF9A-41P-1V (**)	540-0223-5-**-	41	24.3	19	20	23.1	-	20	○	○	○	-	
DF9A-51P-1V (**)	540-0026-4-**-	51	29.3	24	25	28.1	-	16	-	○	-	○	

Note 1 : Please order the tube packaging product by multiplying the packaging quantity (pcs.).

Note 2 : Please order the emboss packaging product per reel. (1000 pcs. per reel)

Note 3 : - are not available. Regarding blank, please contact Hirose sales representative.

Header With metal fitting

Without boss

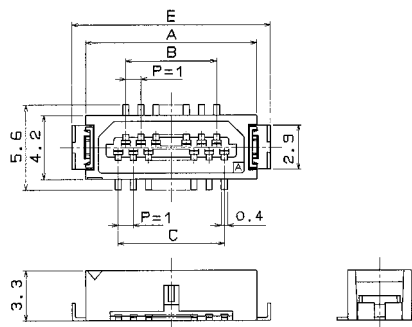
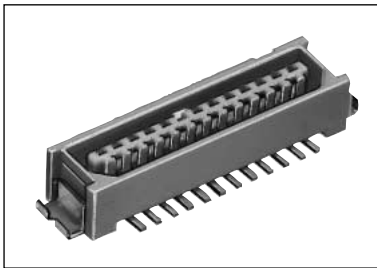

[Specific No.] - **, (**)
 (20) : Tin plating, tube packaging
 (54) : Gold plating, tube packaging
 (22) : Tin plating, embossed tape packaging
 (59) : Gold plating, embossed tape packaging

Unit: mm

Part Number	CL No.	Number of Contacts	A	B	C	D	E	Tube Package Quantity, Pcs./pack	Spec. (20)	Spec. (54)	Spec. (22)	Spec. (59)	Remarks
DF9B- 9P-1V (**)	540-0134-7-**-	9	8.3	3	4	-	10.1	46	-	○	○	○	With metal fitting Without boss With pick and place tape for embossed tape packaging.
DF9B-11P-1V (**)	540-0135-0-**-	11	9.3	4	5	-	11.1	42	○	-	○	-	
DF9B-13P-1V (**)	540-0136-2-**-	13	10.3	5	6	-	12.1	39	○	-	○	-	
DF9B-15P-1V (**)	540-0137-5-**-	15	11.3	6	7	-	13.1	36	○	-	○	○	
DF9B-17P-1V (**)	540-0138-8-**-	17	12.3	7	8	-	14.1	33	-	-	-	○	
DF9B-19P-1V (**)	540-0248-6-**-	19	13.3	8	9	-	15.1	31	-	○	-	○	
DF9B-21P-1V (**)	540-0140-0-**-	21	14.3	9	10	-	16.1	29	○	-	○	-	
DF9B-23P-1V (**)	540-0141-2-**-	23	15.3	10	11	-	17.1	28	-	-	○	-	
DF9B-25P-1V (**)	540-0142-5-**-	25	16.3	11	12	-	18.1	26	○	-	○	-	
DF9B-31P-1V (**)	540-0144-0-**-	31	19.3	14	15	-	21.1	22	○	○	○	○	
DF9B-41P-1V (**)	540-0221-0-**-	41	24.3	19	20	-	26.1	18	○	○	○	-	
DF9B-51P-1V (**)	540-0146-6-**-	51	29.3	24	25	-	31.1	15	-	○	-	○	

Note 1 : Please order the tube packaging product by multiplying the packaging quantity (pcs.).

Note 2 : Please order the emboss packaging product per reel. (1000 pcs./reel)

Note 3 : - are not available. Regarding blank, please contact Hirose sales representative.

◆ Recommended PCB mounting pattern

● With metal fitting, with boss

● Without metal fitting, with boss

● Metal fitting, without boss

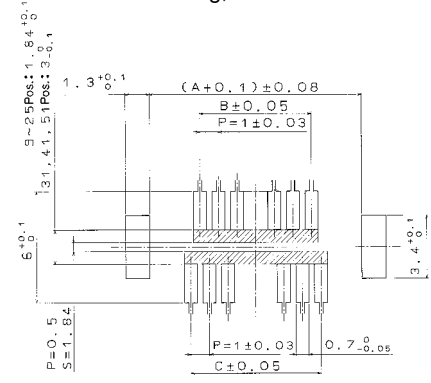
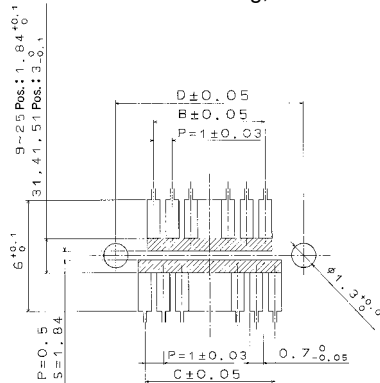
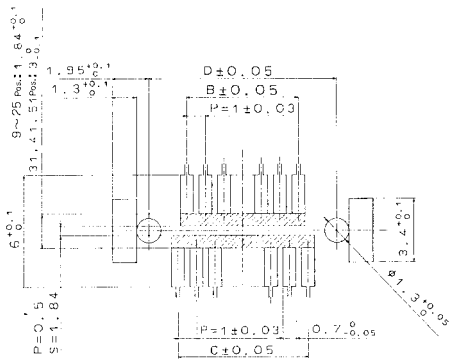

Note 1 : If the pattern is included in the shaded area and not treated with resist, it could touch the connector contact .

Note 2 : Please refer to each product size pattern for the universal size on the above patterns (A, B, C, D...).

◆ Application Pattern

◆ Tube Size

■ Common to Receptacle and Header

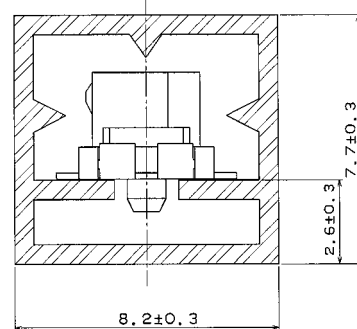
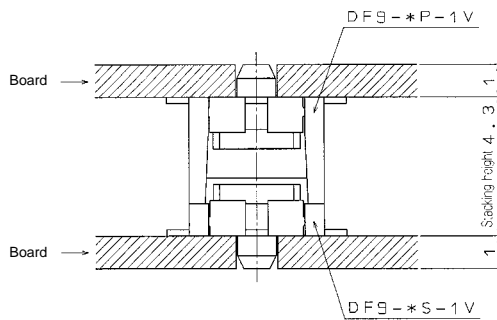

Note 1 : The board to board size 4.3mm in the pattern does not include the soldering paste thickness.

◆ Embossed Carrier Tape Dimensions

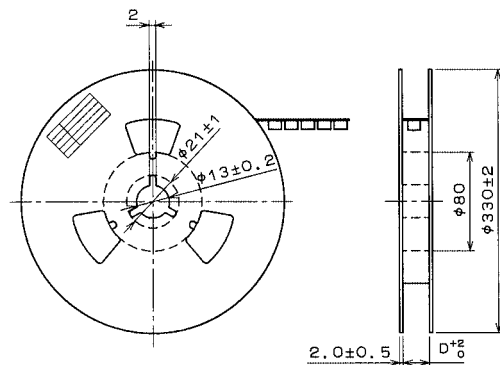
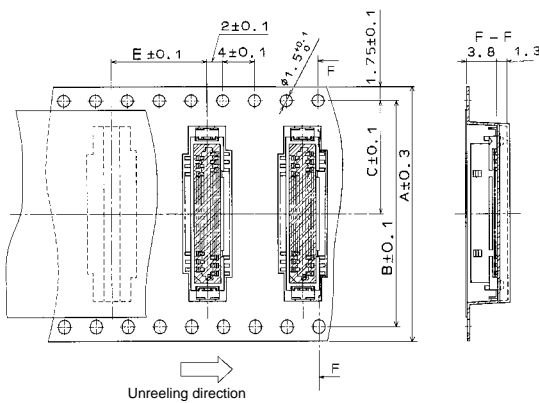

Unit:mm

Product Type	Size	Number of Contacts	A	B	C	D	E
DF9-*S/P-1V		9 to 25	24	—	11.5	24.4	12
		31	32	28.4	14.2	32.4	12
		41, 51	44	40.4	20.2	44.4	12
DF9A-*S/P-1V		9 to 13	16	—	7.5	16.4	8
		15 to 25	24	—	11.5	24.4	12
		31	32	28.4	14.2	32.4	12
DF9B-*S/P-1V		41, 51	44	40.4	20.2	44.4	12
		9 to 25	24	—	11.5	24.4	12
		31	32	28.4	14.2	32.4	12
	41, 51	44	40.4	20.2	44.4	12	

Bottom Entry Header

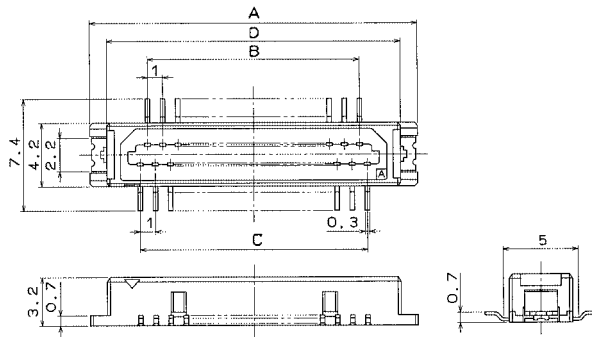
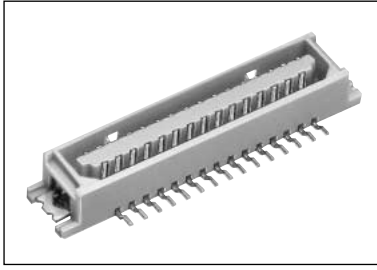

[Specific No.] - **, (**)
 (20): Tin plating tube packaging
 (21): Gold plating embossed tape packaging

Part Number	CL No.	Number of Contacts	A	B	C	D	Tube Packaging Quantity	Spec. (29)	Spec. (21)	Remarks
DF9L-31P-1V (**)	540-0215-7-**	31	21.64	14	15	19.4	22	○	○	With metal fitting

Note 1 : Please order the tube packaging product by multiplying the packaging quantity (pcs.).

Note 2 : Please order the embossed tape packaging product per reel. (1000 pcs. per reel)

Note 3 : The vacuum area on the embossed tape product utilizes the connector case surface. However, it is necessary to check the previous vacuum, because the surface isn't always plain.

Recommended PCB mounting pattern

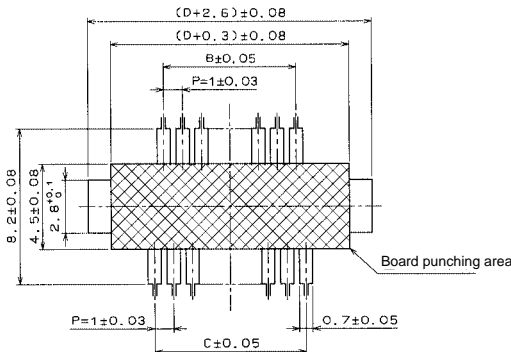

Note : The shaded area indicates the through-hole area.

Application Pattern

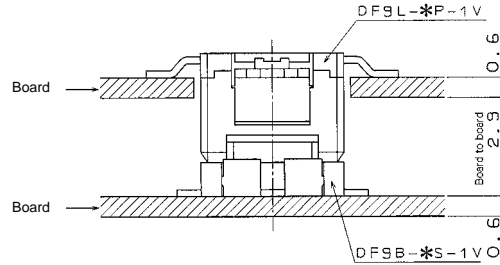

Note : The 2.9mm board to board size does not include the soldering paste thickness.

Tube Size

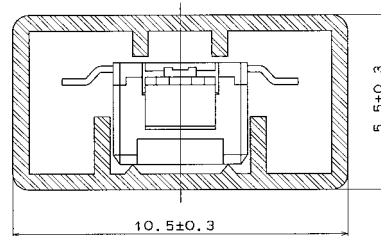

Embossed Carrier Tape Dimensions

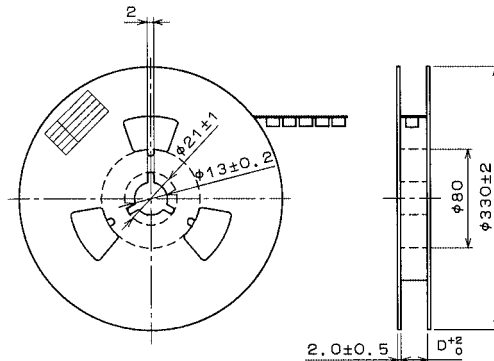
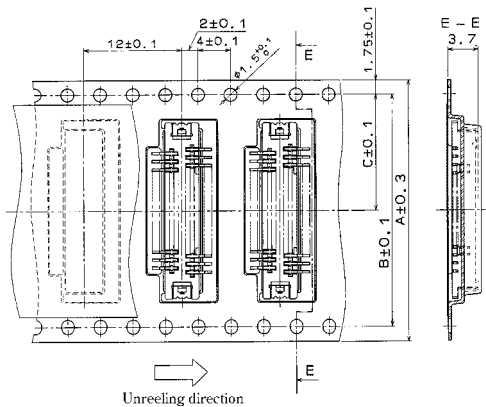

Unit: mm

Product Type	Size	Number of Contacts	A	B	C	D
DF9L-31P-1V		31	32	28.4	14.2	32.4

◆Precautions for Use

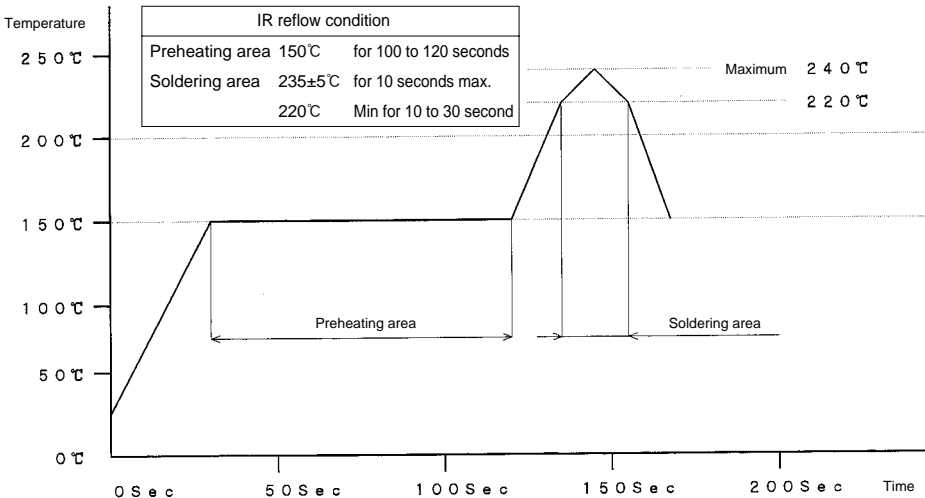
<p>1. Recommended Temperature Profile (SMT)</p>	 <p>IR reflow condition</p> <table border="1" data-bbox="698 170 1079 297"> <tr> <td>Preheating area</td> <td>150°C</td> <td>for 100 to 120 seconds</td> </tr> <tr> <td>Soldering area</td> <td>235±5°C</td> <td>for 10 seconds max.</td> </tr> <tr> <td></td> <td>220°C</td> <td>Min for 10 to 30 second</td> </tr> </table> <p>Maximum 240°C 220°C</p> <p>Note 1 : Maximum twice action is allowed under the same condition. However, the interval between the first process and second actions must be maintained at the room temperature.</p> <p>Note 2 : The temperature indicates the board surface temperature in the connector lead area.</p>	Preheating area	150°C	for 100 to 120 seconds	Soldering area	235±5°C	for 10 seconds max.		220°C	Min for 10 to 30 second
Preheating area	150°C	for 100 to 120 seconds								
Soldering area	235±5°C	for 10 seconds max.								
	220°C	Min for 10 to 30 second								
<p>2. Recommended Manual Soldering Condition (SMT)</p>	<p>Soldering iron temperature: 290±10°C, Soldering time: Within 2 seconds</p>									
<p>3. Recommended Screen Thickness (SMT)</p>	<p>0.15mm</p>									
<p>4. Board Warp(SMT)</p>	<p>Maximum 0.03mm in the connector center area, based on both connector edges.</p>									
<p>5. Cleaning Condition</p>	<p>Refer to the "Nylon Connector Use Hand book".</p>									
<p>6. Cautions</p>	<ul style="list-style-type: none"> ■ Avoid retaining the board with the connector only, and fix the board by any other means than the connector. ■ Where the board is not mounted, the insertion or extraction will cause damage or deformation in contacts. ■ Excessive scoop insertion or extraction may result in damage. ■ In the manual soldering process, don't carry out flux coating which will cause a flux blister on the connector. ■ The color phase of this product may be slightly different from that of the forming product according to the manufacturing lot. However, the difference doesn't affect the performance. 									