

阅读申明

- 1.本站收集的数据手册和产品资料都来自互联网，版权归原作者所有。如读者和版权方有任何异议请及时告之，我们将妥善解决。
- 2.本站提供的中文数据手册是英文数据手册的中文翻译，其目的是协助用户阅读，该译文无法自动跟随原稿更新，同时也可能存在翻译上的不当。建议读者以英文原稿为参考以便获得更精准的信息。
- 3.本站提供的产品资料，来自厂商的技术支持或者使用者的心得体会等，其内容可能存在描述上的差异，建议读者做出适当判断。
- 4.如需与我们联系，请发邮件到marketing@iczoom.com，主题请标有“数据手册”字样。

Read Statement

1. The datasheets and other product information on the site are all from network reference or other public materials, and the copyright belongs to the original author and original published source. If readers and copyright owners have any objections, please contact us and we will deal with it in a timely manner.
2. The Chinese datasheets provided on the website is a Chinese translation of the English datasheets. Its purpose is for reader's learning exchange only and do not involve commercial purposes. The translation cannot be automatically updated with the original manuscript, and there may also be improper translations. Readers are advised to use the English manuscript as a reference for more accurate information.
3. All product information provided on the website refer to solutions from manufacturers' technical support or users the contents may have differences in description, and readers are advised to take the original article as the standard.
4. If you have any questions, please contact us at marketing@iczoom.com and mark the subject with "Datasheets" .

Interface Connectors for Miniature, Portable Terminal Devices

ST Series

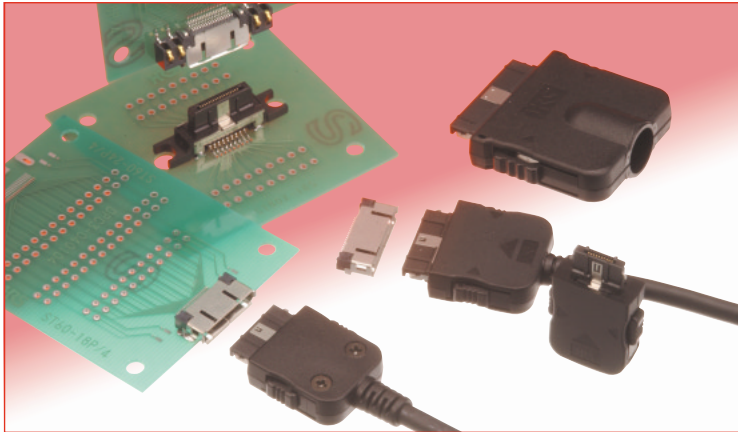

Overview

Developed as external input/output connectors for the portable and mobile devices used in consumer markets. As such, the connectors incorporate features required to assure reliable electrical and mechanical performance under extreme and unpredictable conditions.

Features

1. Strong locking mechanism

To assure continuous reliability of the connection in an unpredictable consumer environment, mated connectors will withstand pull force of 49N max. applied in any direction.

2. Prevention against reversed or angle insertion

Multiple polarization keys will not allow incorrect insertion of the mating plug.

In addition, contacts will not be damaged when the user attempts to insert only the corner of the mating plug.

3. Small size and low profile

Contact pitch of 0.5 mm and utilization of state-of-the-art manufacturing technologies has produced receptacle height of 3 mm above the board and maximum thickness of the plug of only 7 mm.

4. EMI protection

Built-in ground continuity features and EMI shielding assure interference free performance.

5. Wide variety of contact positions and mounting styles

Standard, reverse, vertical and cradle mountings, as well as utilization of variety of cables and conductors assure application of this connector in diversified applications.

Applications

Digital Still Cameras, Personal Digital Assistance, Notebook computers, Cellular phones, Portable readers, Mobile recorders and any mobile or portable device requiring high reliability small size input/output connection.

Strong locking mechanism

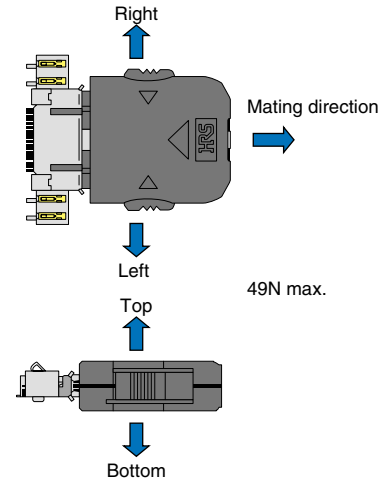

Prevention against reversed or angle insertion

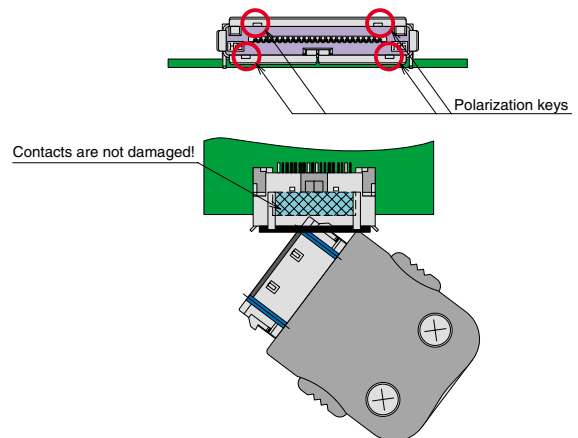

Plug variations

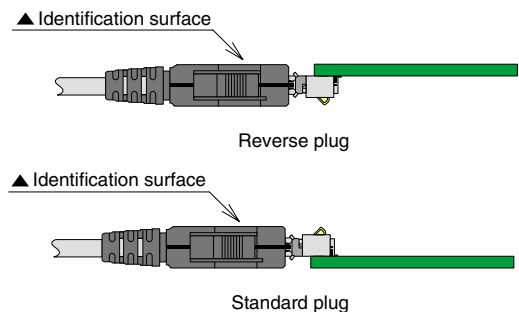

■ Specifications

Rating	Current rating	0.5A (1 A max. can be carried via 4 random contacts)	Operating temperature range	: -30°C to +80°C
	Voltage rating	100V AC	Storage temperature range	: -40°C to +85°C (Note)

Characteristic	Specification	Conditions
1. Contact resistance	60m Ω max.	100mA DC
2. Insulation resistance	100M Ω min.	250V DC
3. Dielectric withstanding voltage	No flashover or insulation breakdown.	350V AC/ one minute
4. Mating/un-mating forces	Mating: 29.4N max.	With corresponding connector.
5. Durability (mating/un-mating)	Contact resistance: 50 m Ω max.	10000 cycles
6. Shock	No electrical discontinuity of 10 μ sec. max. Contact resistance: 100m Ω max.	Acceleration of 490 m/s ² , 11 ms duration, sine half-wave waveform, 3 cycles in each of the 3 axis.
7. Temperature cycle	Contact resistance: 100m Ω max. Insulation resistance: 1000M Ω min.	Temperature : -55°C → +5°C to +35°C → +85°C → +5°C to +35°C Time (Minutes): 30 → 5 → 30 → 5 5 cycles
8. Salt spray	No corrosions	5±1% salt water solution at 35±3°C for 48 hours, after washing without salt, leave for 24 hours at room temperature
9. Lock strength	Fully inserted and locked corresponding connector. No physical damage or electrical failure.	Pull force: 49N max. applied in each of the 3 axis.
10. Shock	No electrical discontinuity of 10 μ sec. max. Contact resistance: 100m Ω max.	Frequency: 10 to 55 Hz, single amplitude of 0.75mm, 2 hours, 3 axis.

Note: Includes temperature rise caused by current flow.

■ Materials

● Receptacles and cradles

Component	Material	Finish	Remarks
Insulator	Thermoplastic compound, glass reinforced	Color: Black	UL94V-0
Contacts	Copper alloy	Contact area: Gold plated	—————
Shield	Stainless steel	Tin alloy plating	—————

● Plugs

Component	Material	Finish	Remarks
Insulator	Thermoplastic compound, glass reinforced	Color: Black	UL94V-0
Contacts	Copper alloy	Contact area: Gold plated	—————
Shield	Stainless steel	—————	—————
Cover	Thermoplastic compound, glass reinforced	—————	UL94-HB

■ Ordering information

● Receptacles

ST 60 - 18 P /4

① ② ④ ⑤ ⑥

● Plugs

ST 40 X - 18 S - CVR

① ② ③ ④ ⑤ ⑦

● Plug - Cradle type

ST 80 X - 18 S

① ② ③ ④ ⑤

① Series name	: ST
② Termination type	60 : Right angle SMT 40 : Solder type 80 : Cradle, vertical, SMT
③ Shield	X : With shield Blank : Without shield
④ Number of positions	
⑤ Contact type	P : Male contact (Receptacle) S : Female contact (Plug)
⑥ Contact arrangement	/4 : Combination, with 4 power contacts
⑦ Plug type	CV : Standard type, for top PCB mount CVR : Reverse type, for bottom PCB mount CV1 : For larger diameter cables

■ Receptacle

● 10 pos.

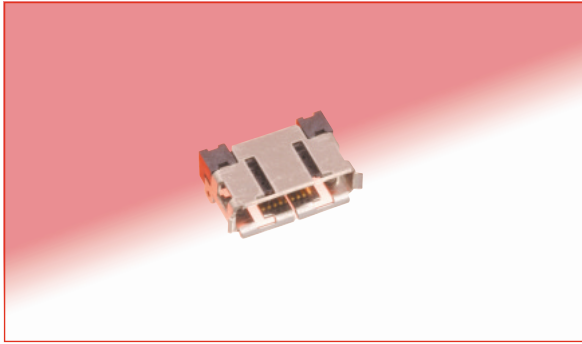

Part Number	CL No.	Packaging
ST60-10P	CL241-0022-5	Reel packaging (1500 pieces/reel)

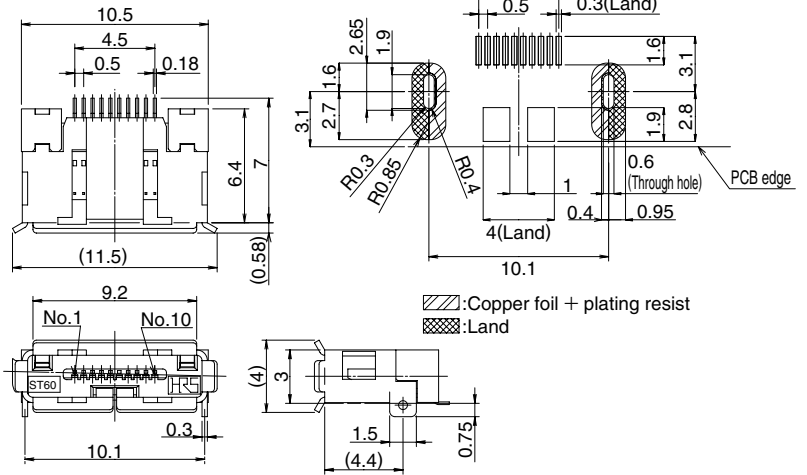

● 18 pos.

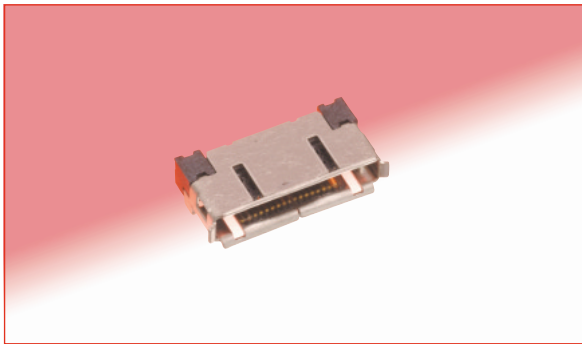

Part Number	CL No.	Packaging
ST60-18P	CL241-0011-9	Reel packaging (1500 pieces/reel)

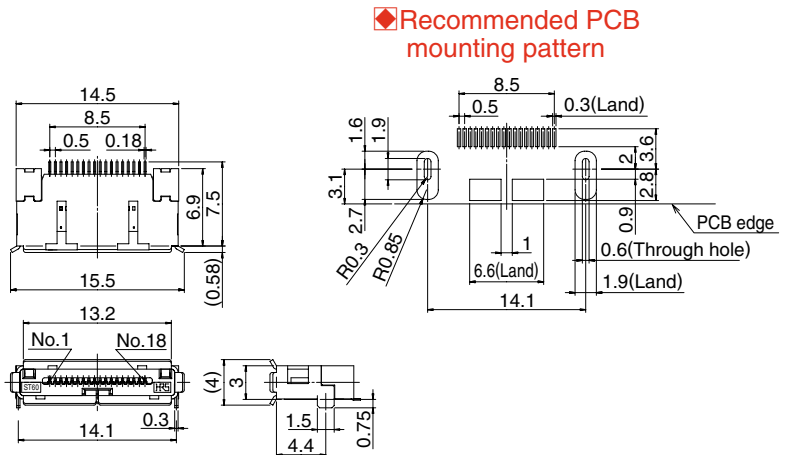

● 18 pos. with 4 power contacts

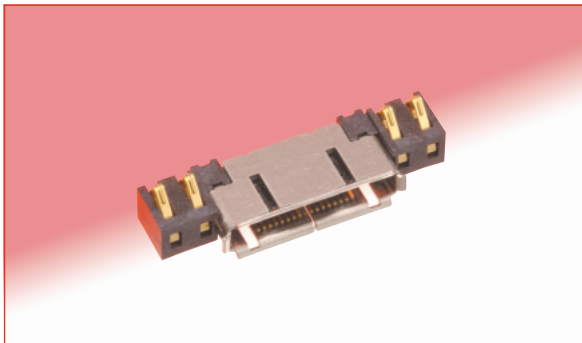

Part Number	CL No.	Packaging
ST60-18P/4	CL241-0005-6	Reel packaging (1000 pieces/reel)

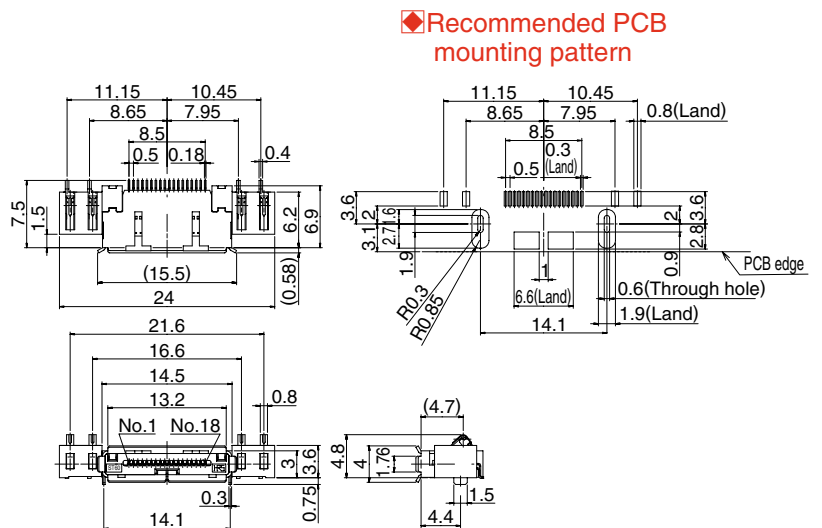

● 24 pos.

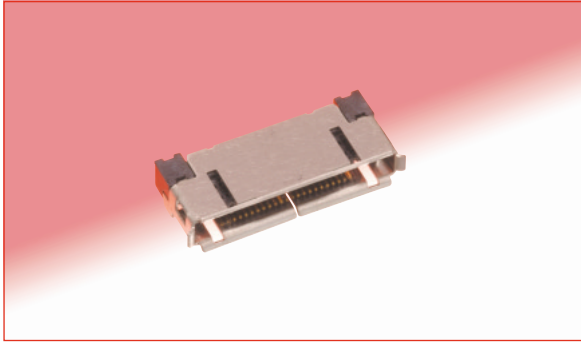

Part Number	CL No.	Packaging
ST60-24P	CL241-0003-0	Reel packaging (1500 pieces/reel)

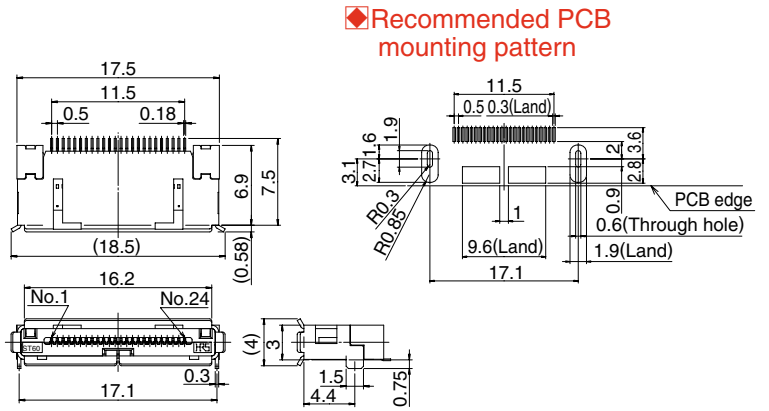

● 36 pos.

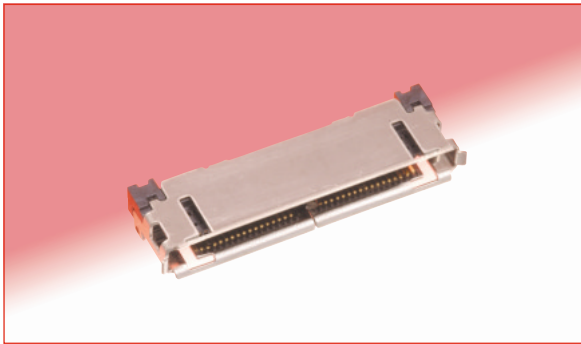

Part Number	CL No.	Packaging
ST60-36P	CL241-0033-1	Reel packaging (1500 pieces/reel)

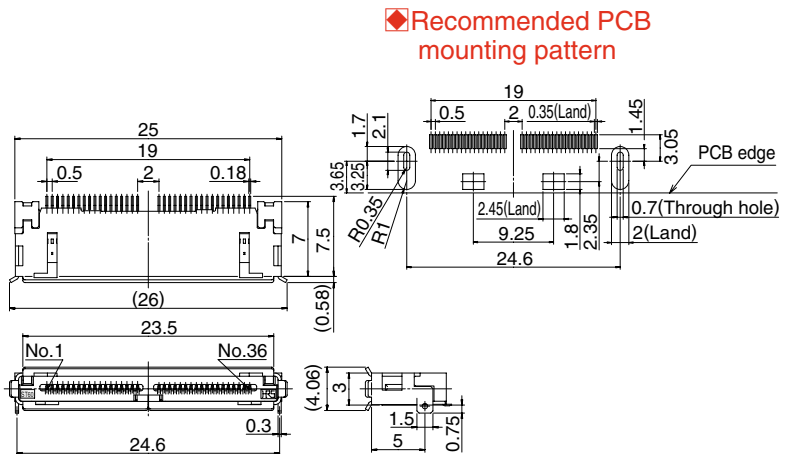

● 36 pos. reverse type

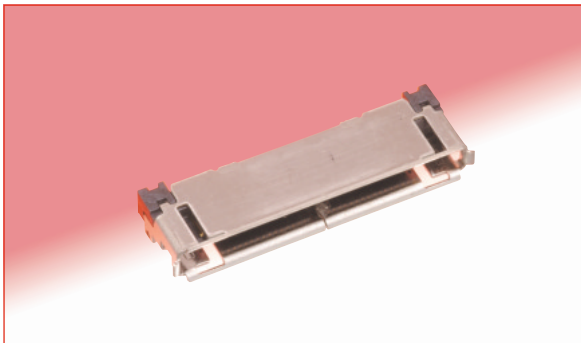

Part Number	CL No.	Packaging
ST60-36PR	CL241-0036-0	Reel packaging (1500 pieces/reel)

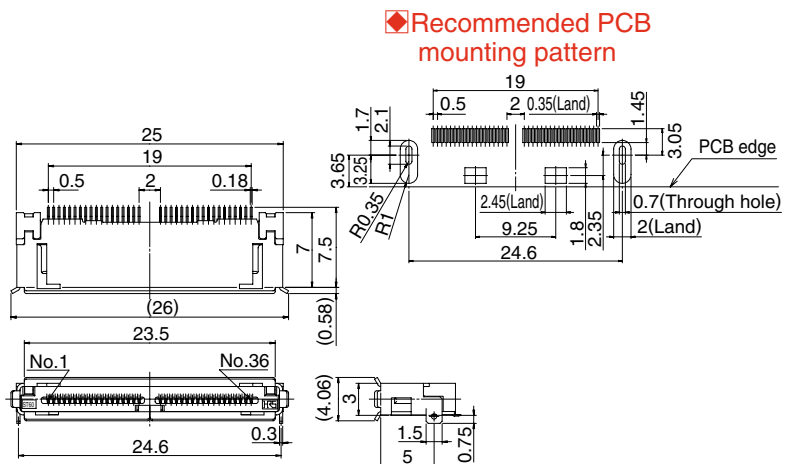

■ Plug – cradle type(Horizontal)

● 18 pos.

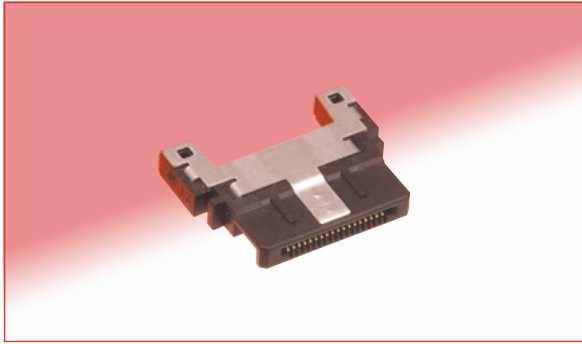

Part Number	CL No.	Packaging
ST60X-18S	CL241-0028-1	Reel packaging (900 pieces/reel)

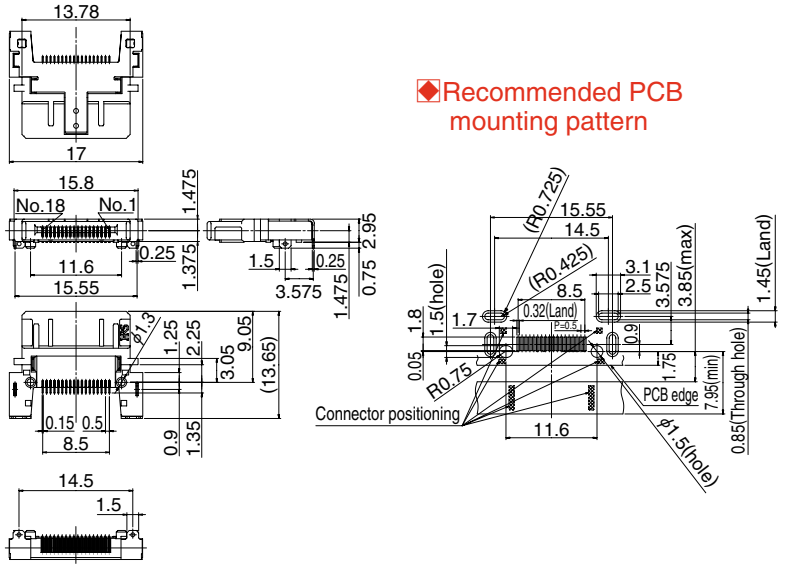

● 36 pos.

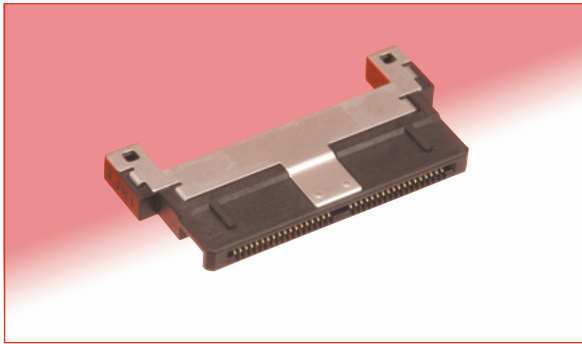

Part Number	CL No.	Packaging
ST60X-36S	CL241-0035-7	Reel packaging (900 pieces/reel)

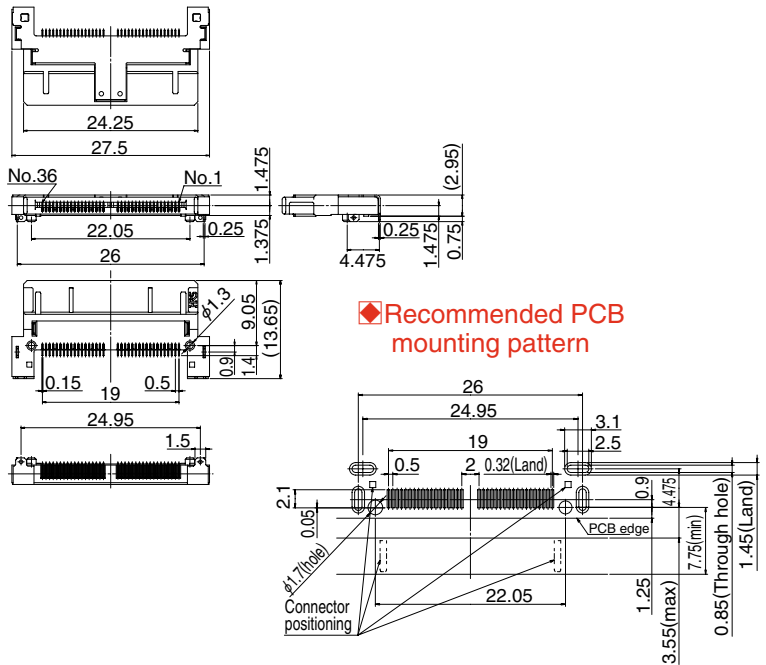

■ Plug – cradle type(Vertical)

● 10 pos.

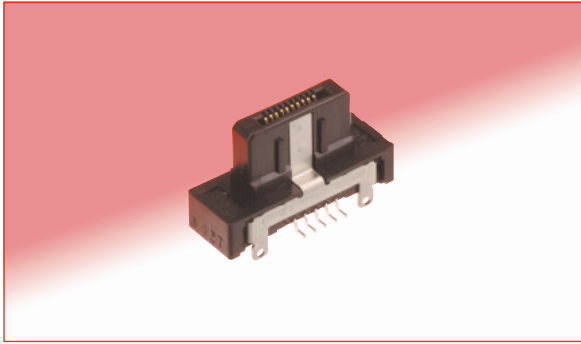

Part Number	CL No.	Packaging
ST80X-10S	CL241-0030-3	Reel packaging (400 pieces/reel)

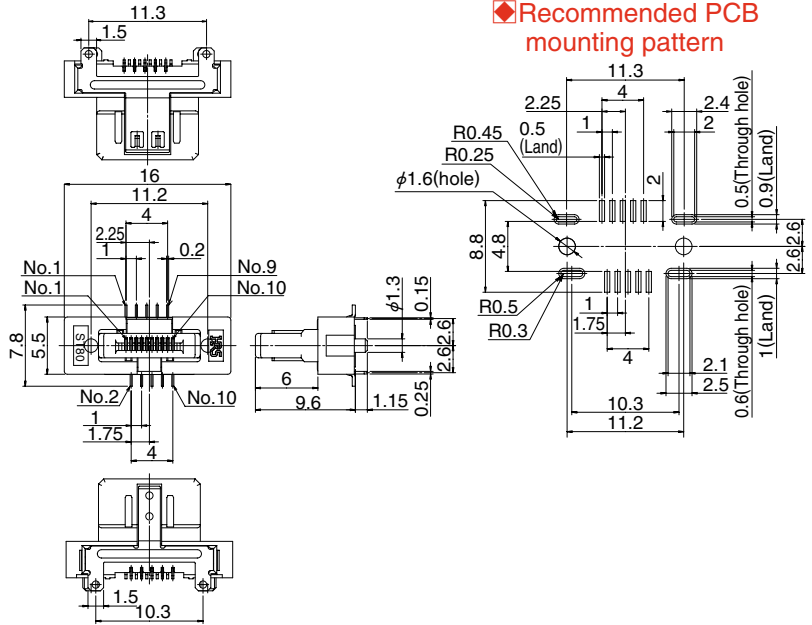

● 18 pos.

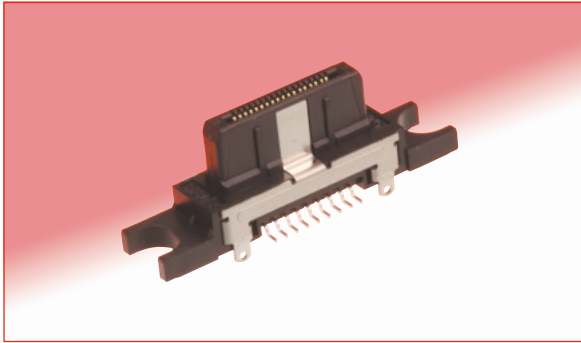

Part Number	CL No.	Packaging
ST80X-18S	CL241-0020-0	Reel packaging (400 pieces/reel)

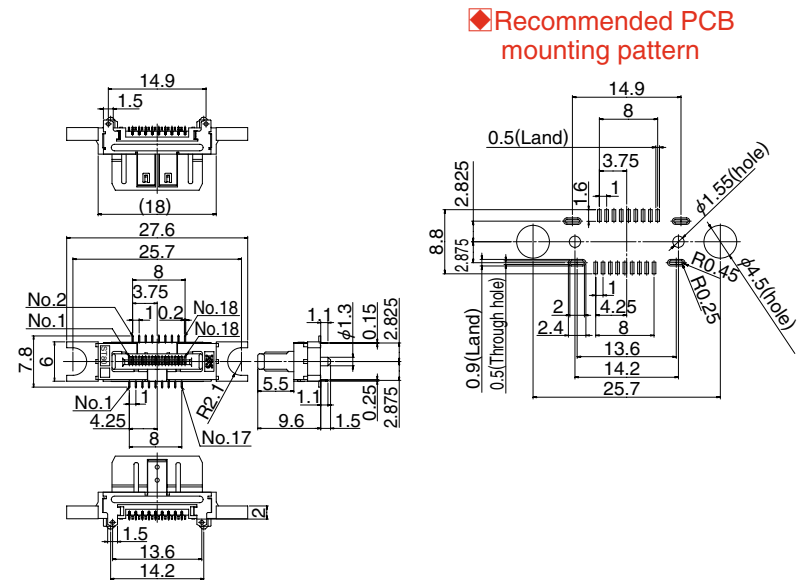

● 24 pos.

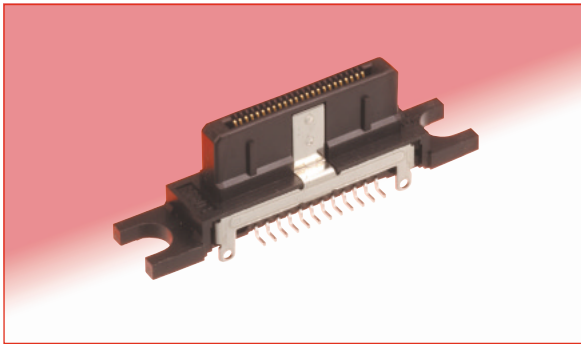

Part Number	CL No.	Packaging
ST80X-24S	CL241-0037-2	Reel packaging (400 pieces/reel)

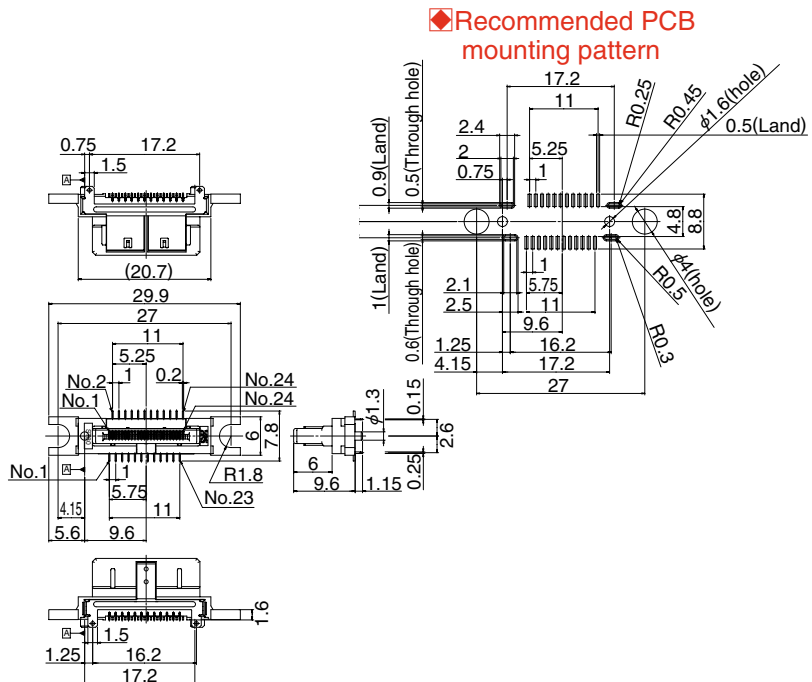

■ Plug

- 10 pos. (Non-shielded type, for 4mm max. cable diameter)

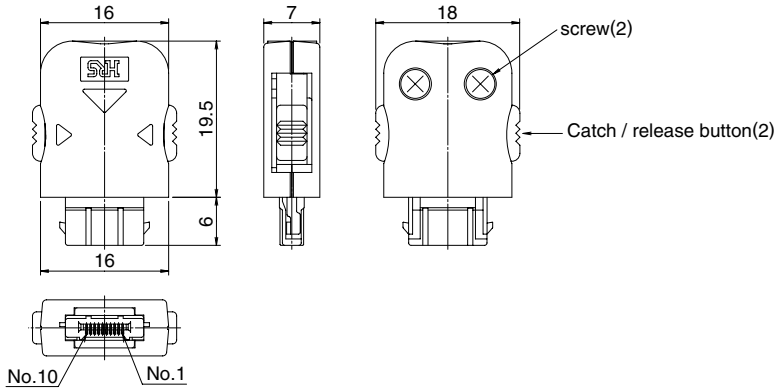
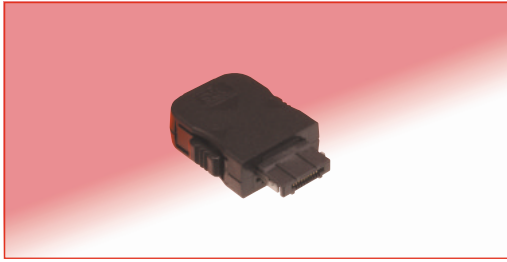

Part Number	CL No.
ST40-10S-CV	CL241-0021-2

- 10 pos. (Reverse, non-shielded type, for 4mm max. cable diameter)

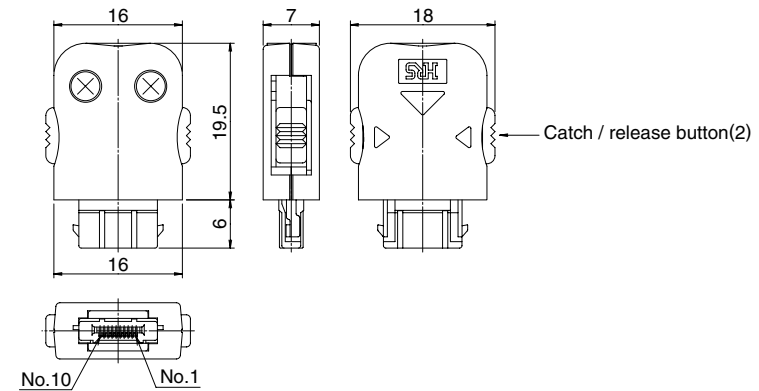
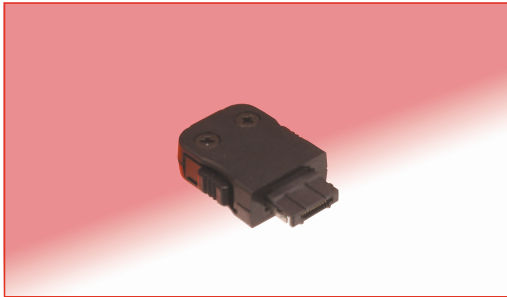

Part Number	CL No.
ST40-10S-CVR	CL241-0040-7

- 10 pos. (Shielded type, for 4mm max. cable diameter)

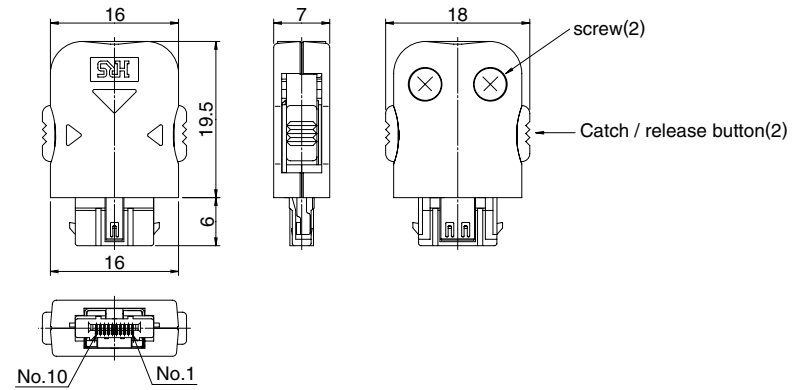
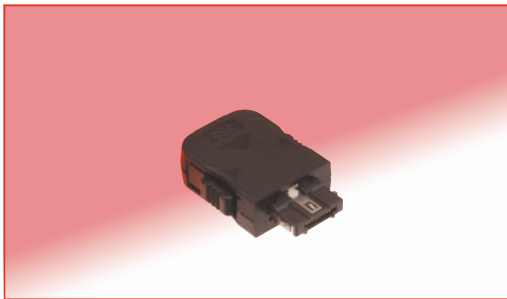

Part Number	CL No.
ST40X-10S-CV	CL241-0041-0

- 10 pos. (Reverse, shielded type, for 4mm max. cable diameter)

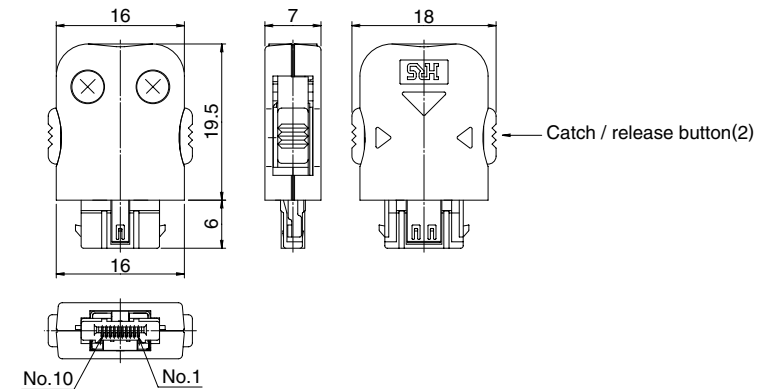

Part Number	CL No.
ST40X-10S-CVR	CL241-0029-4

● 18 pos. (Shielded type, for 4mm max. cable diameter)

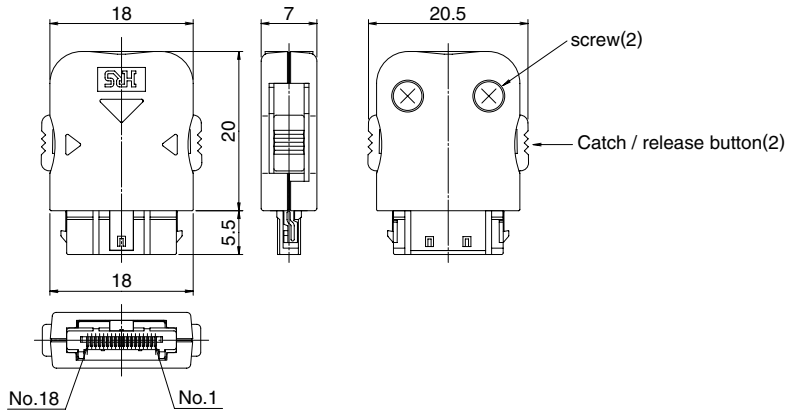

Part Number	CL No.
ST40X-18S-CV	CL241-0012-1

● 18 pos. (Reverse, shielded type, for 4mm max. cable diameter)

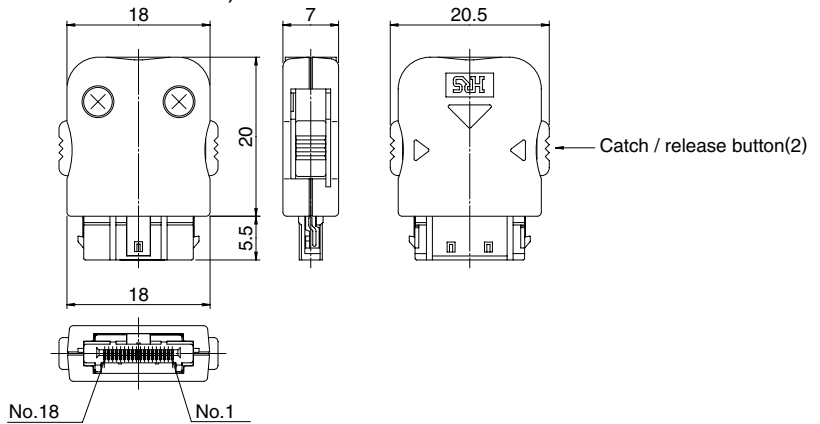
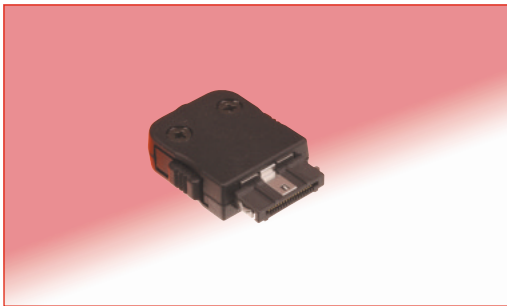

Part Number	CL No.
ST40X-18S-CVR	CL241-0016-2

● 4 pos. (For opening size as 18 pos., reverse, non-shielded, for 4mm max. cable diameter)

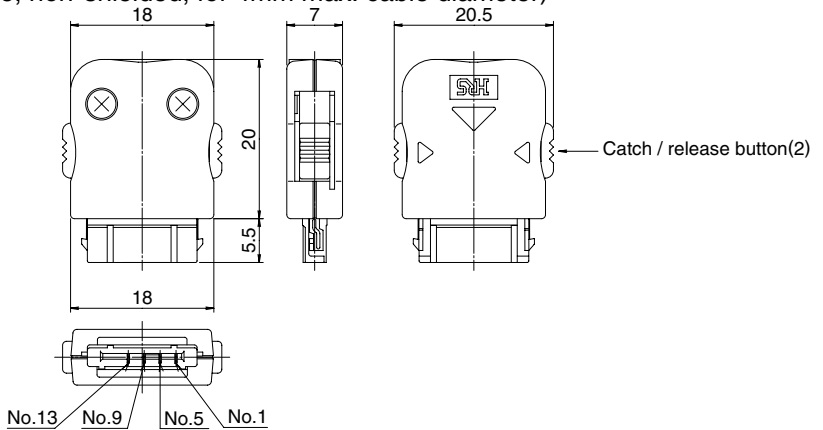

Part Number	CL No.
ST40-18(4)S-CVR	CL241-0032-9

● 24 pos. (Shielded type, for 4mm max. cable diameter)

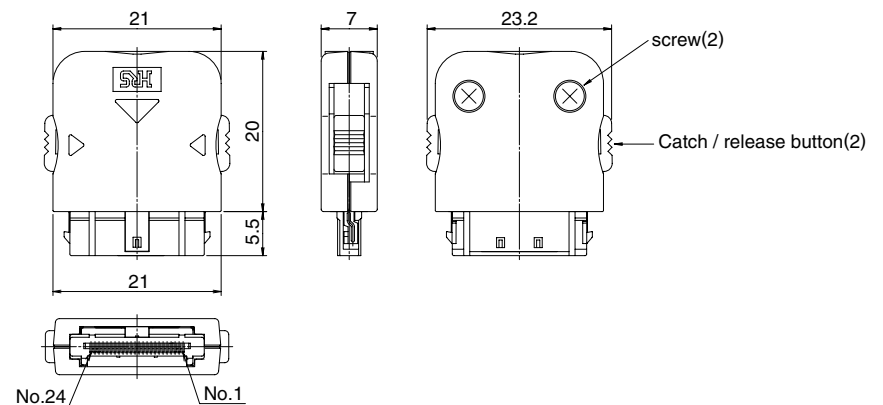

Part Number	CL No.
ST40X-24S-CV	CL241-0004-3

● 24 pos. (Shielded type, for 5.8mm max. cable diameter)

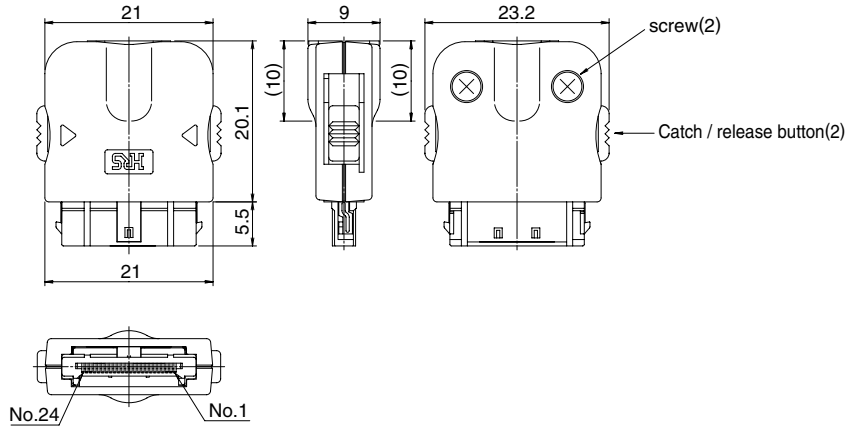

Part Number	CL No.
ST40X-24S-CV1	CL241-0023-8

● 36 pos. (Shielded type, for 7mm max. cable diameter)

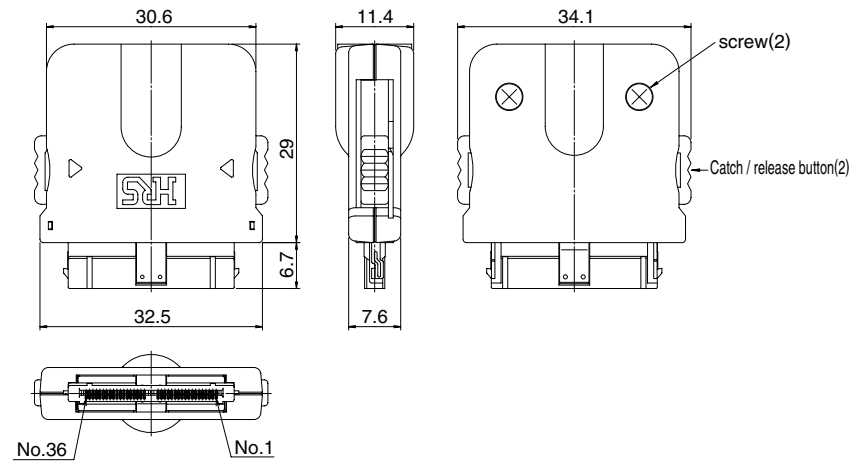
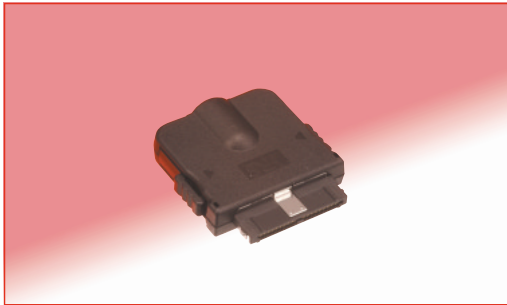

Part Number	CL No.
ST40-36S-CV	CL241-0034-4

Note: Plug assemblies will require additional components. Contact Hirose Electric representative for detailed descriptions and installation instructions.

◆ Packaging Specification

● Embossed Carrier Tape Dimensions

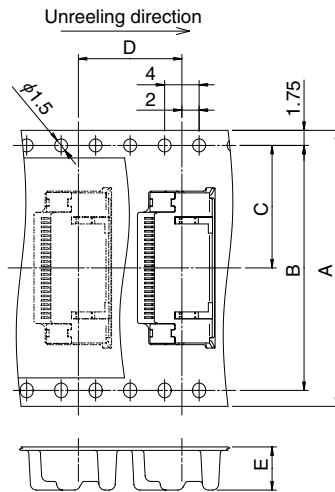

● Reel Dimensions

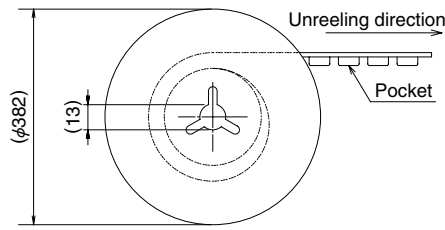

● Reel Dimensions

Part Number	A	B	C	D	E	pcs. / reel
ST60-10P	24	—	11.5	12	5	1500
ST60-18P	24	—	11.5	12	5	1500
ST60-24P	32	28.4	14.2	12	5	1500
ST60-36P	44	40.4	20.2	12	5	1500
ST60-18P/4	44	40.4	20.2	12	6.2	1000
ST60-36PR	44	40.4	20.2	12	5	1500
ST80X-10S	24	—	11.5	16	12.2	400
ST80X-18S	44	40.4	20.2	16	12.7	400
ST80X-24S	44	40.4	20.2	16	12.7	400
ST60X-18S	32	28.4	14.2	20	4.95	900
ST60X-36S	44	40.4	20.2	20	4.85	900

◆ Recommended Temperature Profile (Lead-free soldering compound)

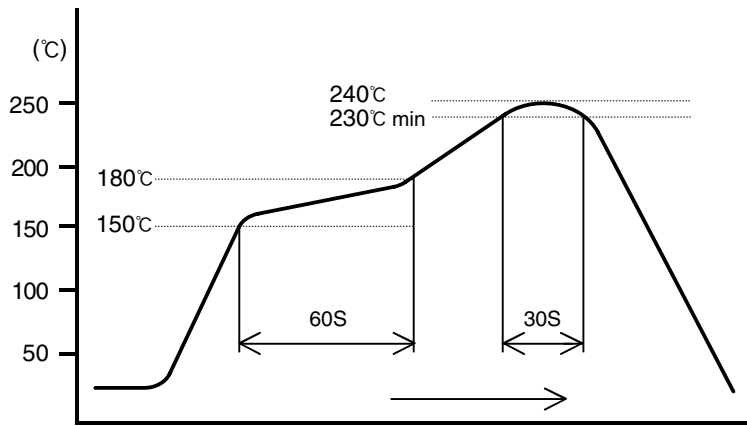

HRS test conditions

Solder composition: Paste, 96.5%Sn/3.0%Ag/0.5%Cu

Test board: Glass epoxy 35mm×35mm×0.8mm thick

The temperature profiles are based on the above conditions. In individual applications the actual temperature may vary, depending on solder paste type, volume/thickness and board size/thickness. Consult your solder paste and equipment manufacturer for specific recommendations.