

## 阅读申明

- 1.本站收集的数据手册和产品资料都来自互联网，版权归原作者所有。如读者和版权方有任何异议请及时告之，我们将妥善解决。
- 2.本站提供的中文数据手册是英文数据手册的中文翻译，其目的是协助用户阅读，该译文无法自动跟随原稿更新，同时也可能存在翻译上的不当。建议读者以英文原稿为参考以便获得更精准的信息。
- 3.本站提供的产品资料，来自厂商的技术支持或者使用者的心得体会等，其内容可能存在描述上的差异，建议读者做出适当判断。
- 4.如需与我们联系，请发邮件到marketing@iczoom.com，主题请标有“数据手册”字样。

## Read Statement

1. The datasheets and other product information on the site are all from network reference or other public materials, and the copyright belongs to the original author and original published source. If readers and copyright owners have any objections, please contact us and we will deal with it in a timely manner.
2. The Chinese datasheets provided on the website is a Chinese translation of the English datasheets. Its purpose is for reader's learning exchange only and do not involve commercial purposes. The translation cannot be automatically updated with the original manuscript, and there may also be improper translations. Readers are advised to use the English manuscript as a reference for more accurate information.
3. All product information provided on the website refer to solutions from manufacturers' technical support or users the contents may have differences in description, and readers are advised to take the original article as the standard.
4. If you have any questions, please contact us at marketing@iczoom.com and mark the subject with "Datasheets" .

POSITIONS/ CONTACTS	A		B	
	INCH±.008	MM±0.20	INCH±.020	MM±0.50
01/02	N/A	N/A	0.050	1.27
02/04	0.050	1.27	0.100	2.54
03/06	0.100	2.54	0.150	3.81
04/08	0.150	3.81	0.200	5.08
05/10	0.200	5.08	0.250	6.35
06/12	0.250	6.35	0.300	7.62
07/14	0.300	7.62	0.350	8.89
08/16	0.350	8.89	0.400	10.16
09/18	0.400	10.16	0.450	11.43
10/20	0.450	11.43	0.500	12.70
11/21	0.500	12.70	0.550	13.97
12/24	0.550	13.97	0.600	15.24
13/26	0.600	15.24	0.650	16.51
14/28	0.650	16.51	0.700	17.78
15/30	0.700	17.78	0.750	19.05
16/32	0.750	19.05	0.800	20.32
17/34	0.800	20.32	0.850	21.59
18/36	0.850	21.59	0.900	22.86
19/38	0.900	22.86	0.950	24.13
20/40	0.950	24.13	1.000	25.40
21/42	1.000	25.40	1.050	26.67
22/44	1.050	26.67	1.100	27.94
23/46	1.100	27.94	1.150	29.21
24/48	1.150	29.21	1.200	30.48
25/50	1.200	30.48	1.250	31.75
26/52	1.250	31.75	1.300	33.02
27/54	1.300	33.02	1.350	34.29
28/56	1.350	34.29	1.400	35.56
29/58	1.400	35.56	1.450	36.83
30/60	1.450	36.83	1.500	38.10
31/62	1.500	38.10	1.550	39.37
32/64	1.550	39.37	1.600	40.64
33/66	1.600	40.64	1.650	41.91
34/68	1.650	41.91	1.700	43.18
35/70	1.700	43.18	1.750	44.45
36/72	1.750	44.45	1.800	45.72
37/74	1.800	45.72	1.850	46.99
38/76	1.850	46.99	1.900	48.26
39/78	1.900	48.26	1.950	49.53
40/80	1.950	49.53	2.000	50.80
41/82	2.000	50.80	2.050	52.07
42/84	2.050	52.07	2.100	53.34
43/86	2.100	53.34	2.150	54.61
44/88	2.150	54.61	2.200	55.88
45/90	2.200	55.88	2.250	57.15
46/92	2.250	57.15	2.300	58.42
47/94	2.300	58.42	2.350	59.69
48/96	2.350	59.69	2.400	60.96
49/98	2.400	60.96	2.450	62.23
50/100	2.450	62.23	2.500	63.50

# PART NUMBER CODING

## GRPB\_\_2VWVN-RC

**NUMBER OF POSITIONS**

(CONTACTS PER ROW, 1 THRU 50)

REVISIONS				
REV.	ECO. NO	DESCRIPTION	DATE	BY
A	1448	INITIAL RELEASE	07/31/07	RAH
B	1660	ADD TOLERANCE TO TABLE	04/15/08	ASK
C	1871	UPDATE POSITION NO., TEXT & TOLERANCE BLOCK, ADD DIM 'A' & R.S. DIM .127	12/08/08	JH

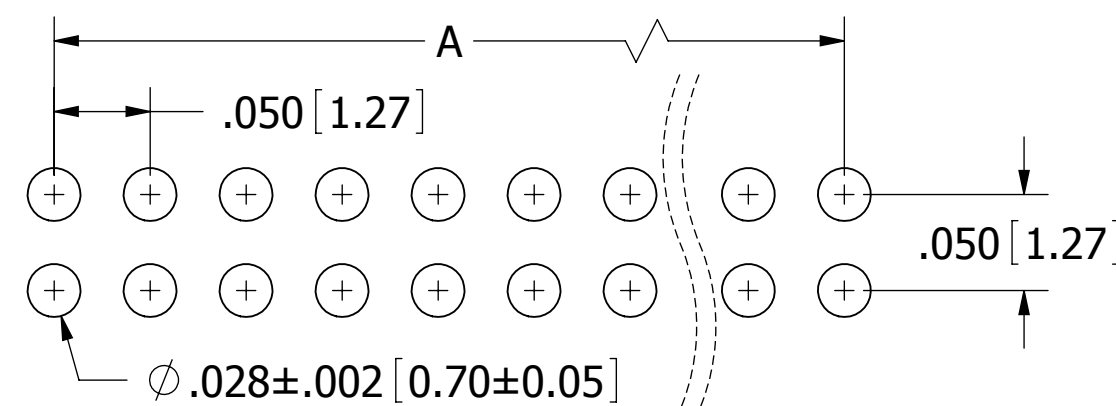
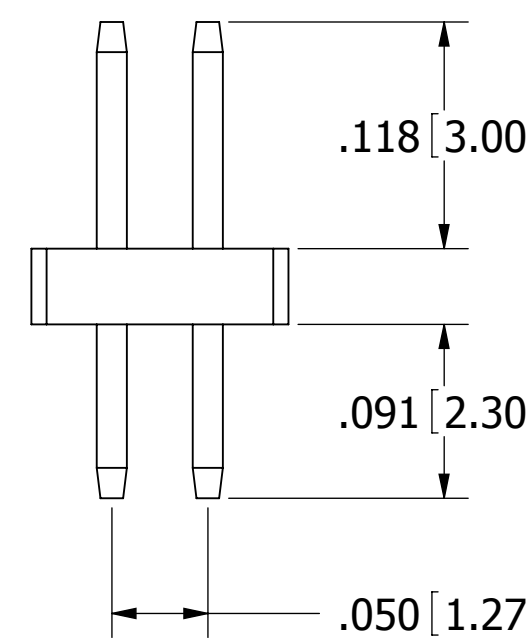
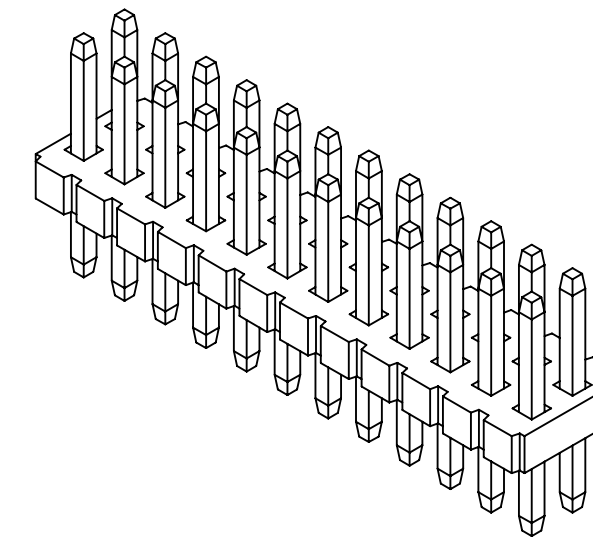
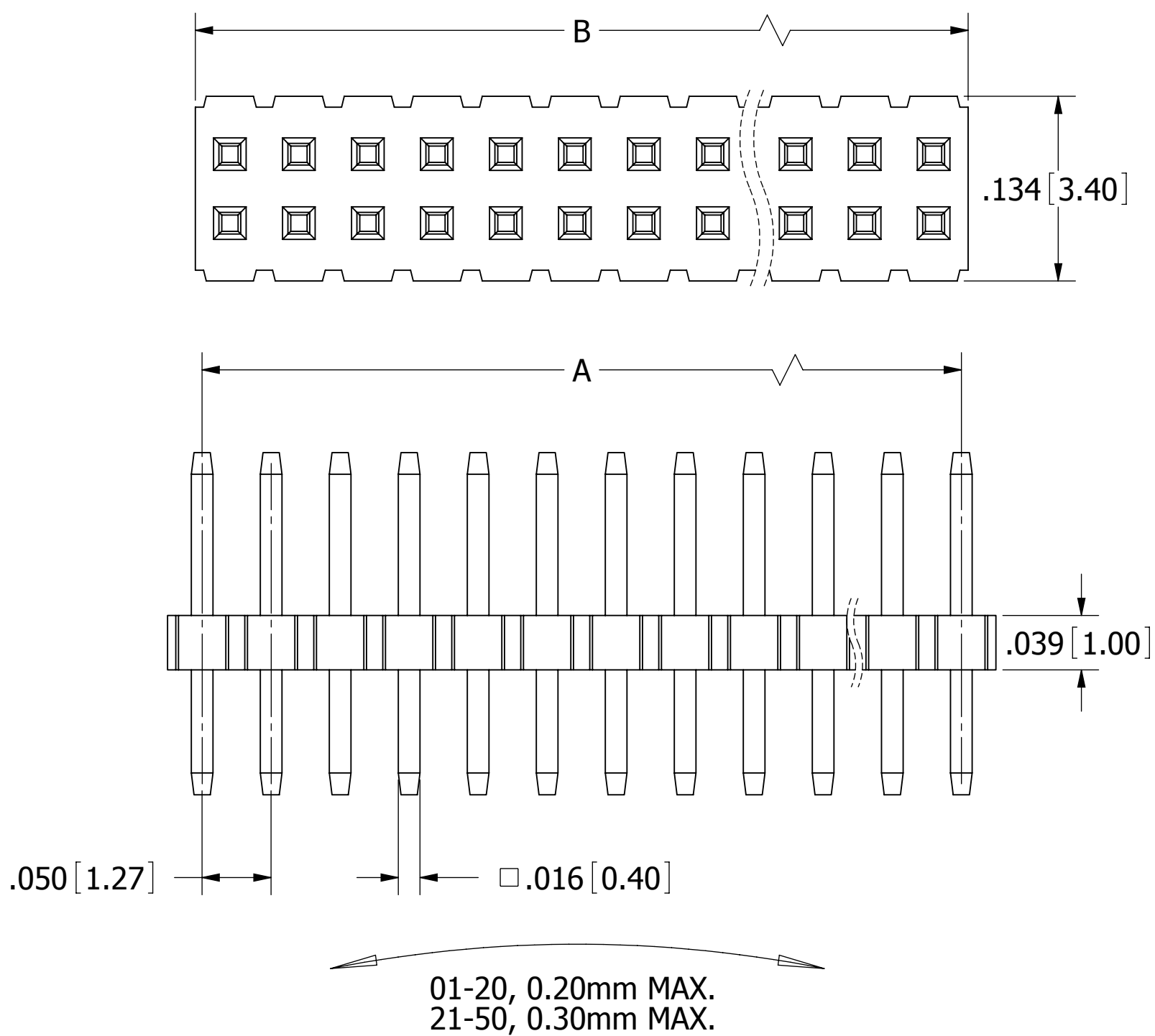

RECOMMENDED PCB HOLE LAYOUT

### NOTES:

- INSULATOR MATERIAL: NYLON 9T.  
\*PROCESSING TEMPERATURE = 260° C FOR 10 SEC.
- CONTACT MATERIAL: BRASS.
- PLATING: GOLD FLASH OVERALL.
- OPERATING TEMPERATURE: -40°C TO +105° C.
- INSULATION RESISTANCE: 5000 MEGA OHM MIN.
- CONTACT RESISTANCE: 20 MILLI OHM MAX.
- DIELECTRIC WITHSTANDING: AC 500V.
- UL FLAMMABILITY RATING: 94V-0.
- CURRENT RATING: 1 AMP.

\*INDICATED TEMPERATURE AND TIME IS FOR COMPONENT INSULATOR. HIGHER PROCESSING TEMPERATURES MAY BE USED, PROVIDED HEAT IS APPLIED FROM BACK SIDE OF PCB, AND INSULATOR DOES NOT EXCEED INDICATED TEMPERATURE AND TIME.

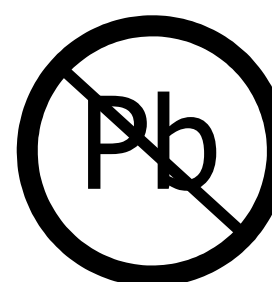

RoHS COMPLIANT

UNLESS OTHERWISE SPECIFIED:  
DIMENSIONS ARE IN INCHES[MM]  
TOLERANCES:  
ANGULAR:  
.XX=± .012 [.30]  
.XXX=± .008 [.20]  
.XXXX=± .004 [.10]  
SURFACE FINISH: 63 Rq  
REMOVE ALL BURRS AND SHARP EDGES .010 MAX

INTERPRET DIMENSIONS AND GEOMETRIC TOLERANCING PER: ANSI Y14.5M-1994

DATE	NAME	SULLINS CONNECTOR SOLUTIONS	
DRAWN 12/08/08	JH	DESCRIPTION .050" DUAL ROW MALE HEADER, ST	
THE INFORMATION HEREIN CONTAINS PROPRIETARY INFORMATION OF SULLINS ELECTRONICS AND IS NOT TO BE REPRODUCED, USED OR DISCLOSED TO OTHERS FOR ANY PURPOSE EXCEPT AS SPECIFICALLY AUTHORIZED IN WRITING BY AN OFFICER OF SULLINS ELECTRONICS.		PART NUMBER <b>GRPB__2VWVN-RC</b>	
SIZE <b>C</b>	DWG. NO. <b>10954</b>	REV <b>C</b>	
SCALE: 12:1		SHEET 1 OF 1	