

阅读申明

- 1.本站收集的数据手册和产品资料都来自互联网，版权归原作者所有。如读者和版权方有任何异议请及时告之，我们将妥善解决。
- 2.本站提供的中文数据手册是英文数据手册的中文翻译，其目的是协助用户阅读，该译文无法自动跟随原稿更新，同时也可能存在翻译上的不当。建议读者以英文原稿为参考以便获得更精准的信息。
- 3.本站提供的产品资料，来自厂商的技术支持或者使用者的心得体会等，其内容可能存在描述上的差异，建议读者做出适当判断。
- 4.如需与我们联系，请发邮件到marketing@iczoom.com，主题请标有“数据手册”字样。

Read Statement

1. The datasheets and other product information on the site are all from network reference or other public materials, and the copyright belongs to the original author and original published source. If readers and copyright owners have any objections, please contact us and we will deal with it in a timely manner.
2. The Chinese datasheets provided on the website is a Chinese translation of the English datasheets. Its purpose is for reader's learning exchange only and do not involve commercial purposes. The translation cannot be automatically updated with the original manuscript, and there may also be improper translations. Readers are advised to use the English manuscript as a reference for more accurate information.
3. All product information provided on the website refer to solutions from manufacturers' technical support or users the contents may have differences in description, and readers are advised to take the original article as the standard.
4. If you have any questions, please contact us at marketing@iczoom.com and mark the subject with "Datasheets" .

1mm Pitch, Board to Cable Lock Connector

DF50 Series



■ Features

1. It provides clear tactile click and secure mating

Locking function and contact mating occur simultaneously, for a clearer tactile click.
(Please refer to Figure 1 on the right)

2. Robust structure resistant to wrenching forces

Thick and robust housing wall provides higher strength against cracking. Insertion depth for mating housings protects against wrenching.
(Please refer to Figure 2 on the right)

3. Robust and reliable lance structure

High lance strength by mating with crimp contact on the surface
(Please refer to Figure 3 on the right)

4. Ensured adsorption area eliminates the need for adsorption gap.

Adequate adsorption area is ensured despite the small size, allowing for automatic mounting without adsorption gap.
(*Specifications for adsorption gap may be provided according to your requirements)

5. Insulation outer diameter $\phi 0.9\text{mm}$, compatible with AWG#28

Despite 1 mm Pitch, it is compatible with $\phi 0.9\text{mm}$, UL1061-AWG#28 Cable ($\phi 0.127 \times 7$)

It provides clear tactile click and secure mating

Timing of locking function

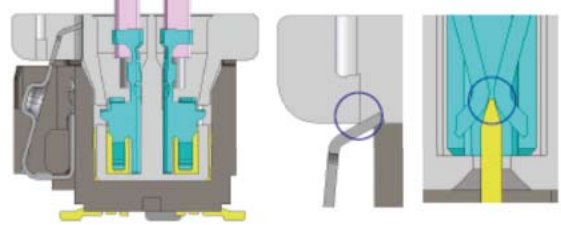

Simultaneous timing of locking function and Figure 1. contact mating provides a clearer tactile click.

Robust structure resistant to wrenching forces

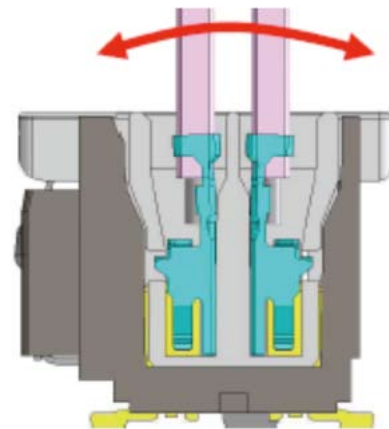

Insertion depth for mating protects against wrenching.
Thick and robust outer wall provides higher strength and prevents cracking.
Figure 2. strength and prevents cracking.

Robust and reliable lance structure

The lance mates with the crimp contact on the surface.

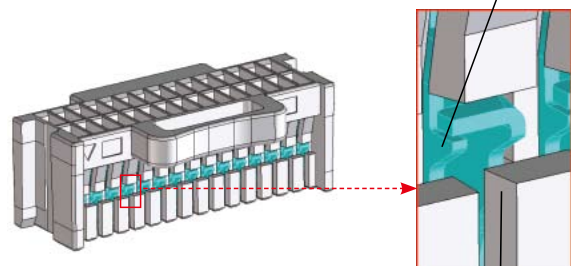

It is possible to visually inspect the assembled lance.

Figure 3.

Product Specifications

Ratings	Current Rating	1A	Operating Temperature Range Operating Humidity Range	-35 to + 85°C (Note 1) 20 to 80%
	Voltage Rating	AC/DC 100V	Storage Temperature Range Storage Humidity Range	-10 to + 60°C (Note 2) 40 to 70% (Note 2)

Items	Specifications	Conditions
1. Insulation resistance	No less than 500MΩ	Measured at DC 100V
2. Withstand voltage	No flashover or breakdown	AC300V is applied for one minute
3. Contact resistance	No more than 30mΩ	Measured at 1mA and no higher than 20mV
4. Vibration Resistance	No electric outage of 1μs or greater	10 cycles in each of three directions at frequency 10-55 Hz, half amplitude 0.75 mm
5. Shock Resistance	No electric outage of 1μs or greater	Accelerated velocity: 490m/s ² for 11ms, half-sine in 3 directions, 3 times for each direction
6. Moisture-resistance	Contact resistance: no more than 50mΩ; insulation resistance: no less than 100MΩ	Temperature: 40±2°C; humidity: 90 to 95%, left as it is for 96 hours
7. Temperature cycles	Contact resistance: no more than 50mΩ; insulation resistance: no less than 500MΩ	(-55°C for 30 minutes → 5 to 35°C for 2 to 3 minutes → 85°C for 30 minutes → 5 to 35°C for 2 to 3 minutes) in 5 cycles
8. Push-pull durability life	Contact resistance: no more than 50mΩ	30 times of push-pull operation
9. Solder Heat Resistance	There should be no dissolution of the resin part which will influence the performance.	Reflow: according to the Recommended Temperature Profile Hand soldering: temperature of soldering iron at 350°C for 3 to 4 seconds

(Note 1) Temperature rise at the time of electrification is included.

(Note 2) The term "storage" refers to the long-term storage condition of unused products before PCB mounting.

Operating Temperature Range is applied to the deenergized state after mounting of PCB and the temporary storage state during transportation.

(Note 3) The above specifications are representative of this series. Please refer to "delivery specifications" for official individual agreement.

Materials

Product	Part	Materials	Color / Treatment	UL Regulation
Header (on the board side)	Insulator	LCP	Black	UL94V-0
	Contact	Brass	Gold plating	—
	Metal fitting	Brass (Note 1)	Tin Plating	—
	Locking metal fittings (DF50)	Stainless steel	—	—
Crimp socket	Insulator	PBT	Black (DF50A) White (DF50S)	UL94V-0
Crimp contact	Contact	Phosphorous Bronze	Gold plating	—

(Note 1) Phosphor bronze is applied a material for only to the single-row straight pin header.

Product Number Structure

●Connector

DF50 – ***** **DP** – **1** **V** ******

① ② ③ ④ ⑤ ⑥

●Crimp contact

DF50 – **2830** **SCF** **A**

① ⑦ ⑧ ⑨

① Series Name: DF50 (Double-row pin header) DF50S (Double-row crimp socket) DF50A (Single-row)	⑤ Wire connection method/Geometry of terminal C: Crimp socket V: SMT Straight Type H: SMT Right Angle Type
② Number of contacts: 20, 30, 40, 50 (Double-row) : 2 to 16 (Single-row)	⑥ Specifications 51: SMT Embossed packaging 52: SMT Embossed packaging (with cap, DF50)
③ Connector type DP: Double-row pin header DS: Double-row socket P: Single-row pin header S: Single-row socket	⑦ Applicable wire size 2830: AWG28, 30 3032: AWG30, 32 (Under development)
④ Contact Pitch: 1mm	⑧ Method type/Packaging type SCF: Socket contact reel
	⑨ Plating specifications A: Gold plating

Double-row straight pin header

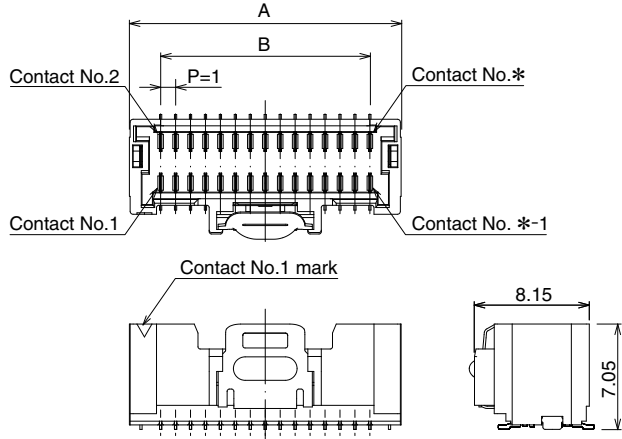
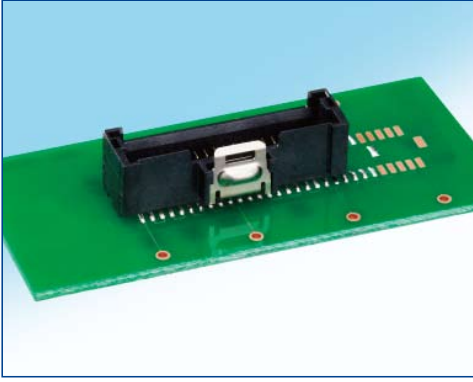

Recommended pattern schematic

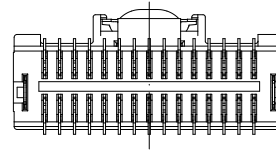
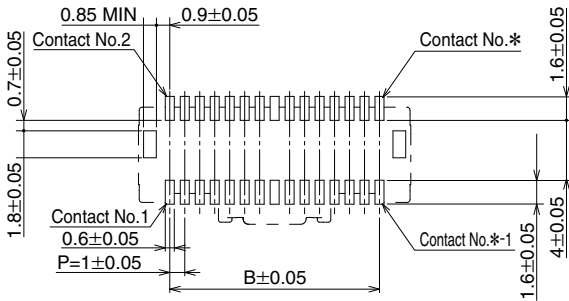

*: No. of Contacts

[Specification Number : **, ()]**
 (51): Gold plating, embossed packaging
 (52): Gold plating, embossed packaging, with adsorption cap

Unit : mm

Product No.	HRS No.	No. of Contacts	A	B	C	D	E	F	G
DF50-20DP-1V (**)	CL665-0019-3-**-	20	13.18	9	14.2	28.4	32	38.4	32.4
DF50-30DP-1V (**)	CL665-0001-8-**-	30	18.18	14	14.2	28.4	32	38.4	32.4
DF50-40DP-1V (**)	CL665-0005-9-**-	40	23.18	19	20.2	40.4	44	50.4	44.4
DF50-50DP-1V (**)	CL665-0011-1-**-	50	28.18	24	20.2	40.4	44	50.4	44.4

(Note) Please place orders for embossed packaged products by the multiple of the number of reels. (1,000 connectors per reel)

Emboss tape dimensions (in conformity to JIS C 0806)

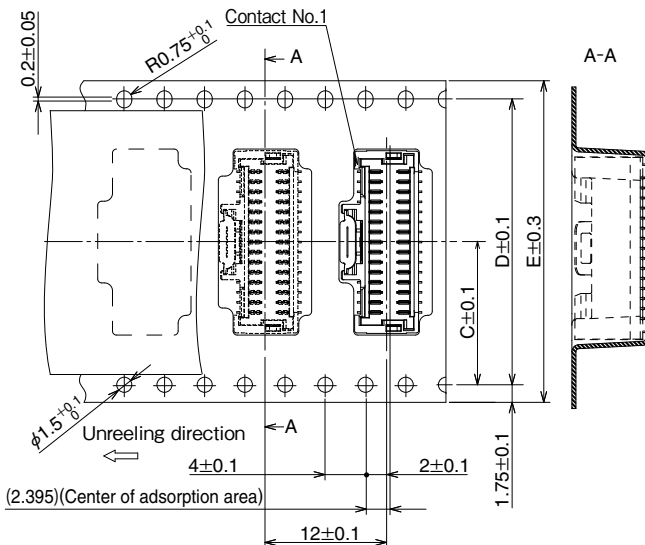

Reel Condition Dimensions

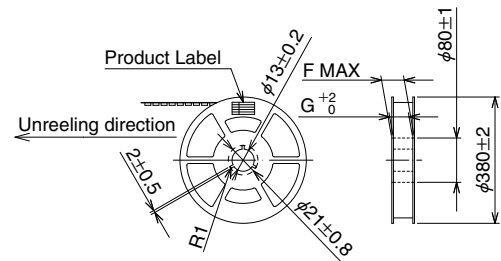

Double-row right angle pin header

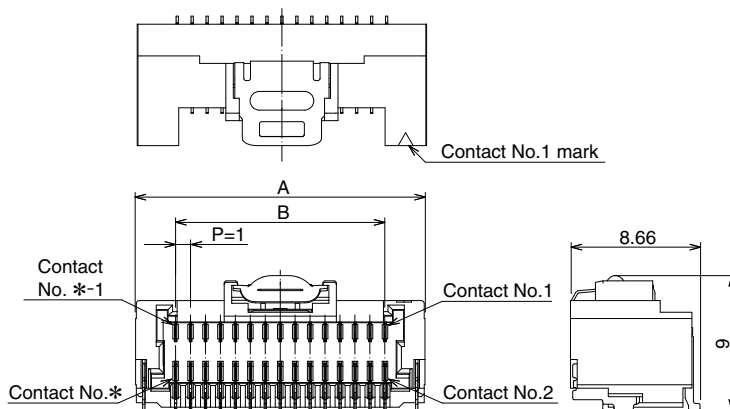
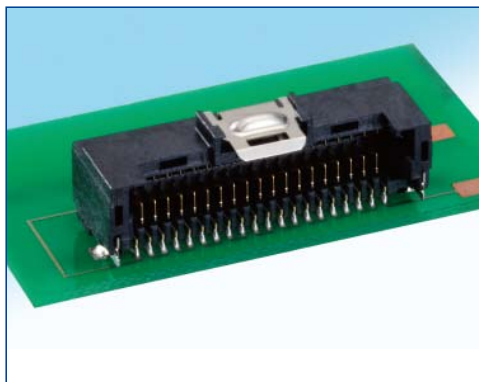

Recommended pattern schematic

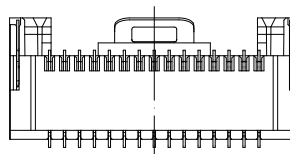
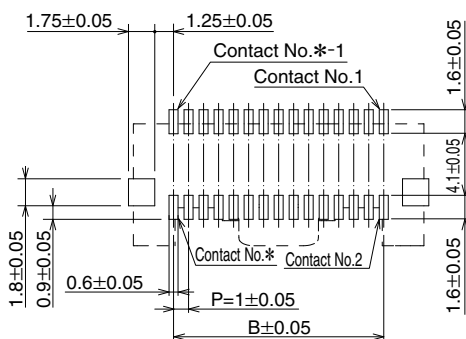

*: No. of Contacts

[Specification Number: **, (**)]
(51): Gold plating, embossed packaging

Unit : mm

Product No.	HRS No.	No. of Contacts	A	B	C	D	E	F	G
DF50-20DP-1H(**)	CL665-0016-5-**	20	14.35	9	14.2	28.4	32	38.4	32.4
DF50-30DP-1H(**)	CL665-0015-2-**	30	19.35	14	20.2	40.4	44	50.4	44.4
DF50-40DP-1H(**)	CL665-0014-0-**	40	24.35	19	20.2	40.4	44	50.4	44.4
DF50-50DP-1H(**)	CL665-0013-7-**	50	29.35	24	20.2	40.4	44	50.4	44.4

(Note) Please place orders for embossed packaged products by the multiple of the number of reels. (1,000 connectors per reel)

Emboss tape dimensions (in conformity to JIS C 0806)

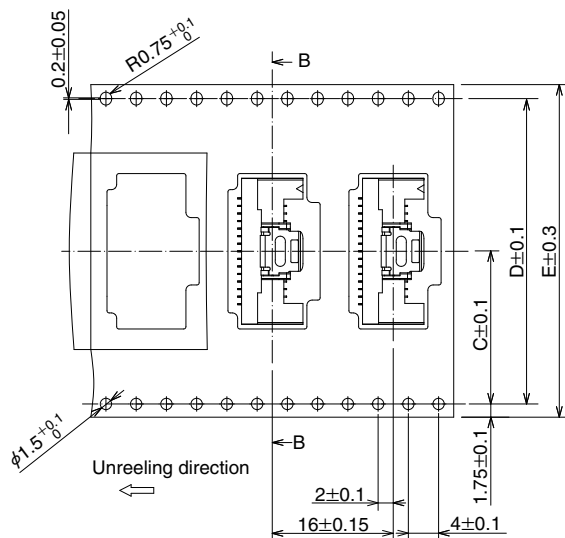

Reel Condition Dimensions

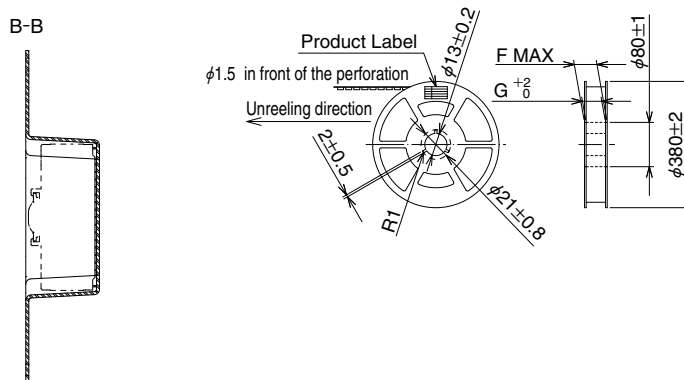

Single-row straight pin header

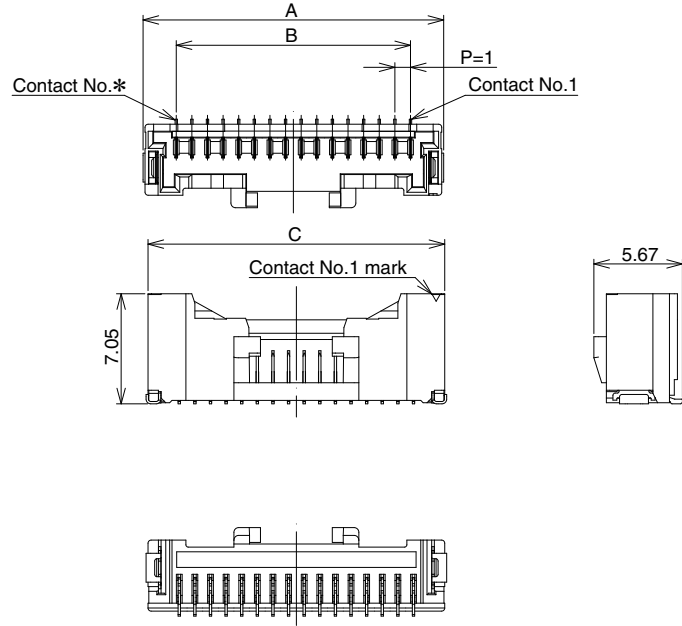
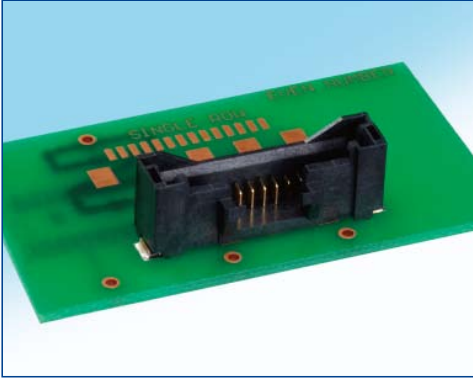

Recommended pattern schematic

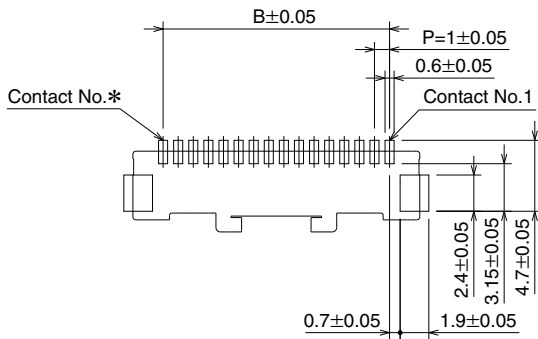

*: No. of Contacts

[Specification Number: **, (**)]
(51): Gold plating, embossed packaging

Unit : mm

Product No.	HRS No.	No. of Contacts	A	B	C
DF50A-2P-1V (**)	CL665-1001-3-**	2	5.25	1	5
DF50A-3P-1V (**)	CL665-1004-1-**	3	6.25	2	6
DF50A-4P-1V (**)	CL665-1006-7-**	4	7.25	3	7
DF50A-5P-1V (**)	CL665-1008-2-**	5	8.25	4	8
DF50A-6P-1V (**)	CL665-1010-4-**	6	9.25	5	9
DF50A-7P-1V (**)	CL665-1012-0-**	7	10.25	6	10
DF50A-8P-1V (**)	CL665-1014-5-**	8	11.25	7	11
DF50A-9P-1V (**)	CL665-1016-0-**	9	12.25	8	12
DF50A-10P-1V (**)	CL665-1017-3-**	10	13.25	9	13
DF50A-11P-1V (**)	CL665-1019-9-**	11	14.25	10	14
DF50A-12P-1V (**)	CL665-1021-0-**	12	15.25	11	15
DF50A-13P-1V (**)	CL665-1023-6-**	13	16.25	12	16
DF50A-14P-1V (**)	CL665-1025-1-**	14	17.25	13	17
DF50A-15P-1V (**)	CL665-1027-7-**	15	18.25	14	18
DF50A-16P-1V (**)	CL665-1029-2-**	16	19.25	15	19

(Note) Please place orders for embossed packaged products by the multiple of the number of reels. (1,000 connectors per reel)

◆ Emboss tape dimensions (in conformity to JIS C 0806)

● DF50A-2P-1V to F50A-8P-1V (Number of contacts: 2 to 8)

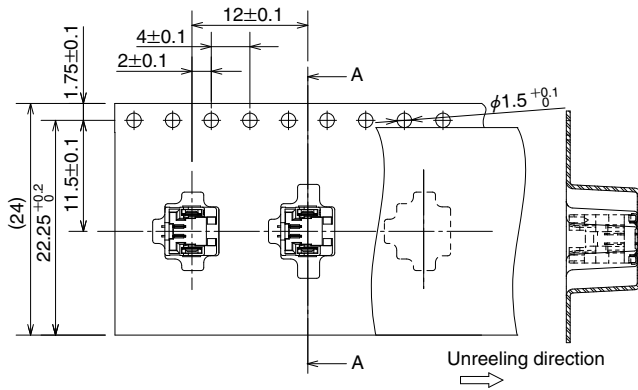

◆ Reel Condition Dimensions

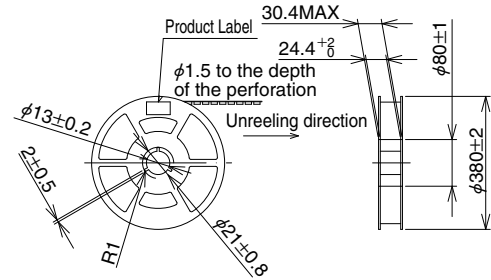

◆ Emboss tape dimensions (in conformity to JIS C 0806)

● DF50A-9P-1V to DF50A-16P-1V (Number of contacts: 9 to 16)

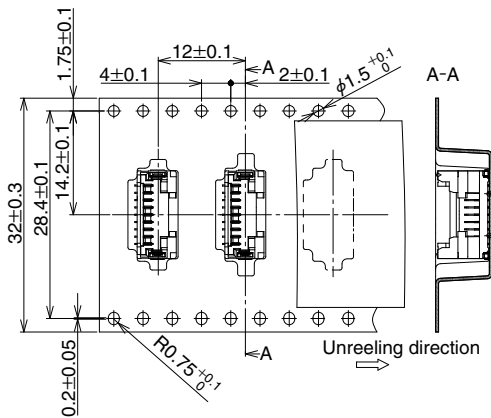

◆ Reel Condition Dimensions

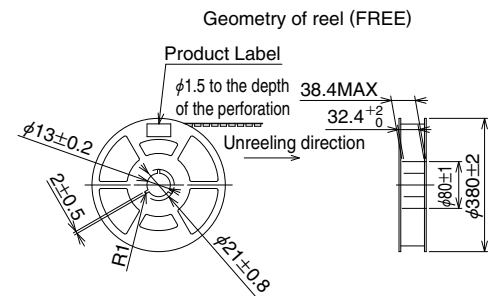

Single-row right angle pin header

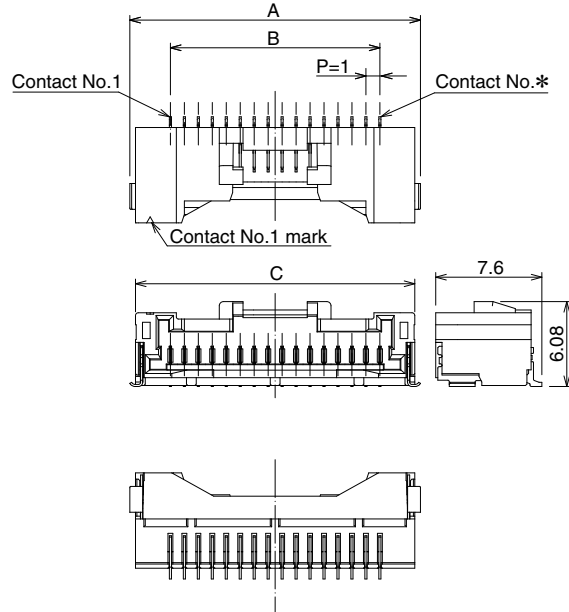
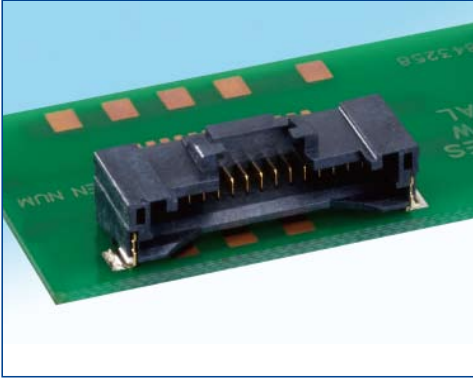

Recommended pattern schematic

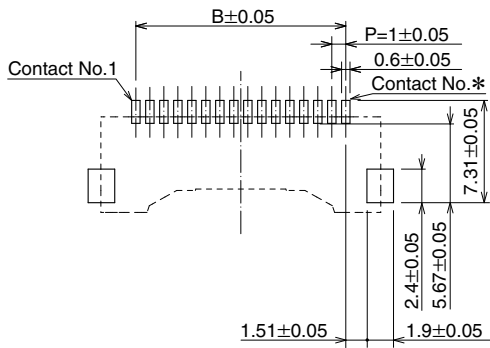

*: No. of Contacts

[Specification Number: **, (**)]
(51): Gold plating, embossed packaging

Unit : mm

Product No.	HRS No.	No. of Contacts	A	B	C
DF50A-2P-1H (**)	CL665-1031-4-**-	2	6.81	1	6
DF50A-3P-1H (**)	CL665-1032-7-**-	3	7.81	2	7
DF50A-4P-1H (**)	CL665-1033-0-**-	4	8.81	3	8
DF50A-5P-1H (**)	CL665-1034-2-**-	5	9.81	4	9
DF50A-6P-1H (**)	CL665-1035-5-**-	6	10.81	5	10
DF50A-8P-1H (**)	CL665-1037-0-**-	8	12.81	7	12
DF50A-10P-1H (**)	CL665-1039-6-**-	10	14.81	9	14
DF50A-12P-1H (**)	CL665-1041-8-**-	12	16.81	11	16
DF50A-16P-1H (**)	CL665-1045-9-**-	16	20.81	15	20

(Note) Please place orders for embossed packaged products by the multiple of the number of reels. (1,000 connectors per reel)

◆ Emboss tape dimensions (in conformity to JIS C 0806)

● DF50A-2P-1H to DF50A-6P-1H (Number of contacts : 2 to 6)

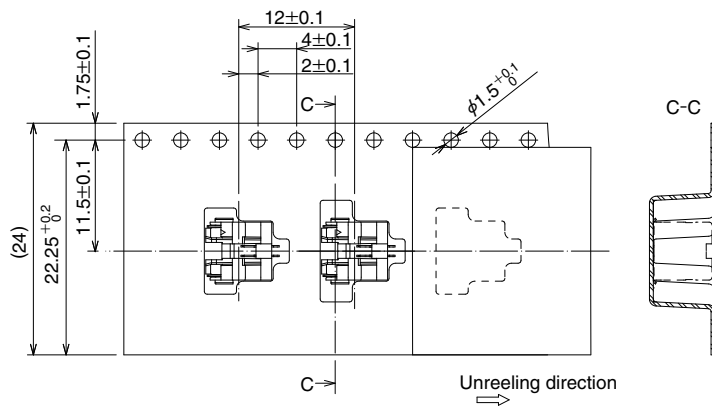

◆ Reel Condition Dimensions

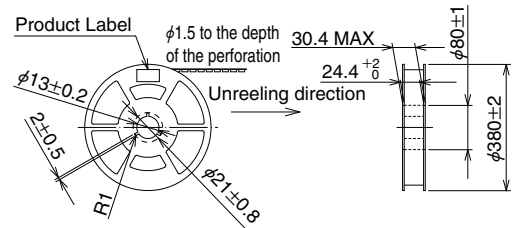

◆ Emboss tape dimensions (in conformity to JIS C 0806)

● DF50A-8P-1H to DF50A-16P-1H (Number of contacts : 8 to 16)

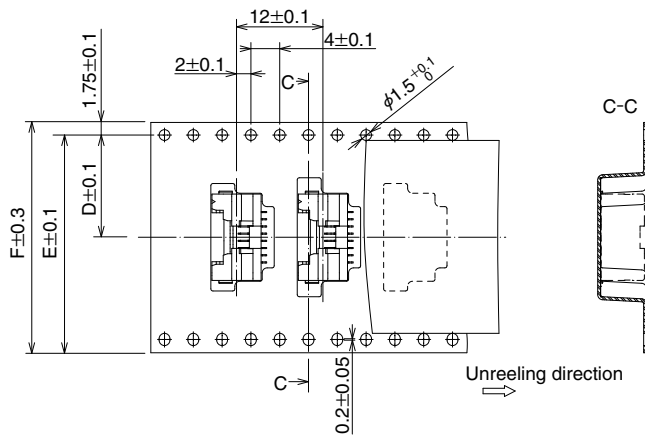

◆ Reel Condition Dimensions

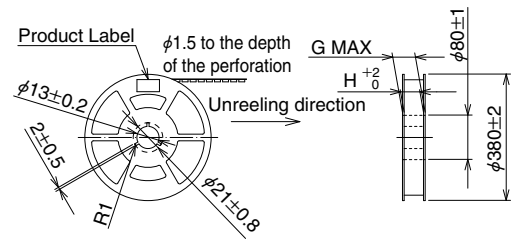

Unit : mm

Product No.	HRS No.	No. of Contacts	D	E	F	G	H
DF50A-8P-1H (**)	CL665-1037-0-**-	8	14.2	28.4	32	38.4	32.4
DF50A-10P-1H (**)	CL665-1039-6-**-	10	20.2	28.4	32	38.4	32.4
DF50A-12P-1H (**)	CL665-1041-8-**-	12	20.2	28.4	32	38.4	32.4
DF50A-16P-1H (**)	CL665-1045-9-**-	16	20.2	40.4	44	50.4	44.4

(Note) Please place orders for embossed packaged products by the multiple of the number of reels. (1,000 connectors per reel)

Double-row crimp socket

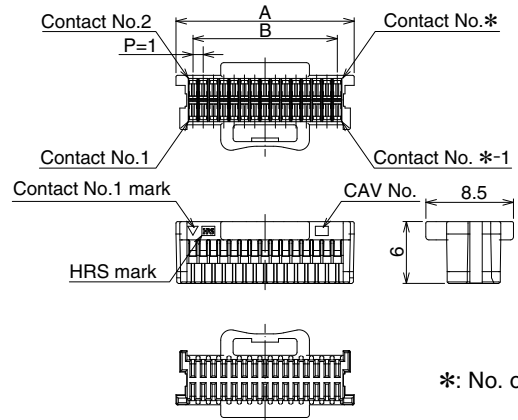

*: No. of Contacts

Unit : mm

Product No.	HRS No.	No. of Contacts	A	B
DF50S-20DS-1C	CL665-0020-2-00	20	12.28	9
DF50S-30DS-1C	CL665-0021-5-00	30	17.28	14
DF50S-40DS-1C	CL665-0022-8-00	40	22.28	19
DF50S-50DS-1C	CL665-0012-4-00	50	27.28	24

(Note) Sold in 100 piece units.

Single-row crimp socket

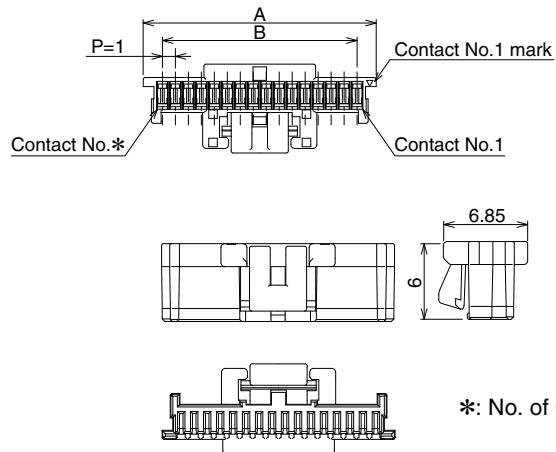

*: No. of Contacts

Unit : mm

Product No.	HRS No.	No. of Contacts	A	B
DF50A-2S-1C	CL665-1002-6-00	2	3.95	1
DF50A-3S-1C	CL665-1005-4-00	3	4.95	2
DF50A-4S-1C	CL665-1007-0-00	4	5.95	3
DF50A-5S-1C	CL665-1009-5-00	5	6.95	4
DF50A-6S-1C	CL665-1011-7-00	6	7.95	5
DF50A-7S-1C	CL665-1013-2-00	7	8.95	6
DF50A-8S-1C	CL665-1015-8-00	8	9.95	7
DF50A-9S-1C	CL665-1100-5-00	9	10.95	8
DF50A-10S-1C	CL665-1018-6-00	10	11.95	9
DF50A-11S-1C	CL665-1020-8-00	11	12.95	10
DF50A-12S-1C	CL665-1022-3-00	12	13.95	11
DF50A-13S-1C	CL665-1024-9-00	13	14.95	12
DF50A-14S-1C	CL665-1026-4-00	14	15.95	13
DF50A-15S-1C	CL665-1028-0-00	15	16.95	14
DF50A-16S-1C	CL665-1030-1-00	16	17.95	15

(Note) Sold in 100 piece units.

■ Crimp contact

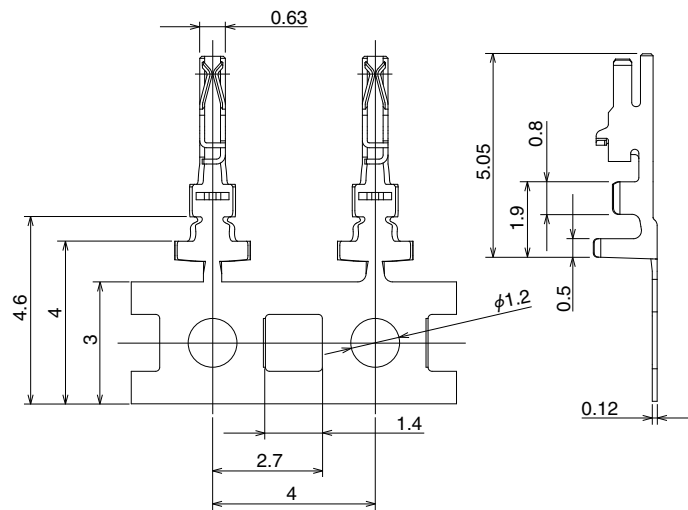

Product No.	HRS No.	Type	Quantity	Treatment
DF50-2830SCFA	CL665-0002-0-00	Reel contact	30,000 pieces per reel	Gold plating
DF50K-2830SCFA	CL665-0017-8-00	Reel contact	30,000 pieces per reel	Gold plating
DF50-3032SCFA	Under development	—	—	—

(Note) As this product is sold per (30,000 piece) reel, please place orders by the multiple of the number of reels.

● Applicable wire (Tinned Annealed Copper Wire)

Product No.	HRS No.	Recommended wire		
		Cable name	Conductor size (Core structure)	Diameter of the wire
DF50-2830SCFA	CL0665-0002-0-00	UL1061	AWG28 (7pieces / φ0.127mm)	φ0.8 to 0.9mm
		UL1061	AWG30 (7pieces / φ0.102mm)	
DF50K-2830SCFA	CL0665-0017-8-00	UL1571	AWG28 (7pieces / φ0.13mm)	φ0.58mm

● Strip length

1.3 to 1.7mm

(Note) Please contact our Sales Department when you are using wires other than applicable wires.

■ Applicable crimping tool

Type	Product No.	HRS No.	Applicable contact
Applicator	AP105-DF50-2830S	CL901-4616-0	DF50-2830SCFA
Press body	CM-105	CL901-0005-4	—
Hand tool	HT305/DF50-2830HC	CL902-4634-8	DF50-2830SCFA
Pull-out tool	DF-C-PO(B)	CL550-0179-2	DF50-2830SCFA

(Note) Problems caused by tools other than our specified ones are out of warranty events.

◆ Precautions

<p>1.Recommended Temperature Profile (Compatible with lead-free soldering)</p>	<p>[Applicable Conditions]</p> <ol style="list-style-type: none"> 1.Peak temperature: a maximum of 250°C for no more than 10 seconds 2.Heating unit: no less than 220°C for no more than 60 seconds 3.Preheating unit: 150 to 180°C for 90 to 120 seconds 4.Number of times: no more than 2 times <p>* Measurement is conducted at the contact lead part As it may change depending on the conditions such as solder paste types, manufacturers, PCB size, and other soldering materials, please fully check the mounting conditions before use.</p> <p>(Note 1) This temperature profile is a recommended value.</p>
<p>2.Recommended hand soldering conditions</p>	<p>Temperature of soldering iron: 350±10°C, soldering time: 3 to 4 seconds</p>
<p>3.Recommended screen thickness and aperture ratio (Pattern surface ratio)</p>	<p>Thickness: 0.1mm, aperture ratio: 100%</p>
<p>4.Warpage of the Board</p>	<p>A maximum of 0.02mm at the center of connector, as measured from either end of the connector</p>
<p>5.Cleaning Conditions</p>	<p>IPA cleaning is allowed. (Cleaning is not recommended because cleaning may change the push/pull feeling etc. Please contact us when you use other cleaning agents.)</p>
<p>6.Precautions</p>	<ul style="list-style-type: none"> ■ When inserting a crimp contact into a crimp socket, do not insert it at a slanted angle in order to maintain the reliability of its performance. ■ Please refrain from pushing/pulling operation when the PCB is not mounted. It may cause breakage, contact deformation, etc. ■ Please refrain from pushing/pulling operation with wires in your hand. It may cause damage. ■ During hand soldering, do not apply flux which will cause flux oozing on connector. ■ This product may have a little difference in its molded color depending on the production lot, but the difference doesn't have any influence on the performance.

USA:

HIROSE ELECTRIC (U.S.A.), INC. Headquarters

2688 Westhills Court, Simi Valley, CA 93065-6235
 Phone : +1-805-522-7958
 Fax : +1-805-522-3217
<http://www.hiroseusa.com>

USA:

HIROSE ELECTRIC (U.S.A.), INC. San Jose Office

3255 Scott Boulevard, Building 7, Suite 101 Santa Clara, CA 95054
 Phone : +1-408-253-9640
 Fax : +1-408-253-9641
<http://www.hiroseusa.com>

USA:

HIROSE ELECTRIC (U.S.A.), INC. Detroit Office (Automotive)

37677 Professional Center Drive, Suite #100C Livonia, MI 48154
 Phone : +1-734-542-9963
 Fax : +1-734-542-9964
<http://www.hiroseusa.com>

THE NETHERLANDS:

HIROSE ELECTRIC EUROPE B.V.

Hogehillweg #8 1101 CC Amsterdam Z-0
 Phone : +31-20-6557460
 Fax : +31-20-6557469
<http://www.hiroseeurope.com>

GERMANY:

HIROSE ELECTRIC EUROPE B.V. German Branch

Herzog-Carl-Strasse 4 D-73760 Ostfildern (Scharnhauser Park)
 Phone : +49-711-4560-02-1
 Fax : +49-711-4560-02-299
<http://www.hirose.de>

UNITED KINGDOM:

HIROSE ELECTRIC EUROPE B.V. UK Branch

22 Vincent Avenue, Crownhill Business Centre, Crownhill, Milton Keynes, MK8 0AB
 Phone : +44-1908-305750
 Fax : +44-1908-305768
<http://www.hirose.co.uk>

CHINA:

HIROSE ELECTRIC TRADING (SHANGHAI) CO., LTD.

1601,Henderson Metropolitan,NO.300 ,East Nanjing Road,Huangpu District, Shanghai,China 200001
 Phone : +86-21-6391-3355
 Fax : +86-21-6391-3335
<http://www.hirose-china.com.cn>

CHINA:

HIROSE ELECTRIC TRADING (SHANGHAI) CO., LTD. Beijing Branch

A1001, Ocean International Center, Building 56# East 4th Ring Middle Road, Chao Yang District, Beijing, 100025
 Phone : +86-10-5165-9332
 Fax : +86-10-5908-1381
<http://www.hirose-china.com.cn>

CHINA:

HIROSE ELECTRIC TECHNOLOGIES (SHENZHEN) CO., LTD.

Room 09-13, 19/F, Office Tower Shun Hing Square, Di Wang Commercial Centre 5002, ShenNanDong Road, ShenZhen City, Guangdong Province, 518008
 Phone : +86-755-8207-0851
 Fax : +86-755-8207-0873
<http://www.hirose-china.com.cn>

HONG KONG:

HIROSE ELECTRIC HONGKONG TRADING CO., LTD.

Room 1001, West Wing, Tsim Sha Tsui Centre, 66 Mody Road, Tsim Sha Tsui East, Kowloon, Hong Kong
 Phone : +852-2803-5338
 Fax : +852-2591-6560
<http://www.hirose-hongkong.com.hk>

TAIWAN:

HIROSE ELECTRIC TAIWAN CO., LTD.

103 8F, No.87, Zhengzhou Rd., Taipei
 Phone : +886-2-2555-7377
 Fax : +886-2-2555-7350
<http://www.hirose-taiwan.com.tw>

KOREA:

HIROSE KOREA CO., LTD.

1261-10, Jeoungwhang-Dong, Shihung-City, Kyunggi-Do 429-450
 Phone : +82-31-496-7000,7124
 Fax : +82-31-496-7100
<http://www.hirose.co.kr>

SINGAPORE:

HIROSE ELECTRIC SINGAPORE PTE. LTD.

10 Anson Road #26-1 International Plaza 079903
 Phone : +65-6324-6113
 Fax : +65-6324-6123
<http://www.hirose-singapore.com.sg>

INDIA:

HIROSE ELECTRIC SINGAPORE PTE. LTD. Bangalore Liaison office

Unit No.03, Ground Floor, Explorer Building International Tech Park Whitefield Road, Bangalore 560066 Karnataka, India
 Phone : +65-6324-6113
 Fax : +65-6324-6123
<http://www.hirose-singapore.com.sg>

INDIA:

HIROSE ELECTRIC SINGAPORE PTE. LTD Delhi Liaison Office

Suite No. 606 5th Floor SB Tower 1A/1 Sector 16 A Filmcity Noida 201301 Uttar Pradesh-India
 Phone : +91-120-4804917
 Fax : +91-120-4804949
<http://www.hirose.com/sg/>

MALAYSIA:

HIROSE ELECTRIC SINGAPORE PTE. LTD (Representative office)

1-10-07, Suntech @ Penang Cybercity (1164),Lintang Mayang Pasir 3,11950, Bayan Baru, Penang, Malaysia.
 Phone : +604-619-2564
 Fax : +604-619-2574
<http://www.hirose.com/sg/>



HIROSE ELECTRIC CO.,LTD.

6-3,Nakagawa Chuoh-2-Chome,Tsuzuki-Ku,Yokohama-Shi 224-8540,JAPAN
 TEL: +81-45-620-3526 Fax: +81-45-591-3726
<http://www.hirose.com>
<http://www.hirose-connectors.com>