

## 阅读申明

- 1.本站收集的数据手册和产品资料都来自互联网，版权归原作者所有。如读者和版权方有任何异议请及时告之，我们将妥善解决。
- 2.本站提供的中文数据手册是英文数据手册的中文翻译，其目的是协助用户阅读，该译文无法自动跟随原稿更新，同时也可能存在翻译上的不当。建议读者以英文原稿为参考以便获得更精准的信息。
- 3.本站提供的产品资料，来自厂商的技术支持或者使用者的心得体会等，其内容可能存在描述上的差异，建议读者做出适当判断。
- 4.如需与我们联系，请发邮件到marketing@iczoom.com，主题请标有“数据手册”字样。

## Read Statement

1. The datasheets and other product information on the site are all from network reference or other public materials, and the copyright belongs to the original author and original published source. If readers and copyright owners have any objections, please contact us and we will deal with it in a timely manner.
2. The Chinese datasheets provided on the website is a Chinese translation of the English datasheets. Its purpose is for reader's learning exchange only and do not involve commercial purposes. The translation cannot be automatically updated with the original manuscript, and there may also be improper translations. Readers are advised to use the English manuscript as a reference for more accurate information.
3. All product information provided on the website refer to solutions from manufacturers' technical support or users the contents may have differences in description, and readers are advised to take the original article as the standard.
4. If you have any questions, please contact us at marketing@iczoom.com and mark the subject with "Datasheets" .

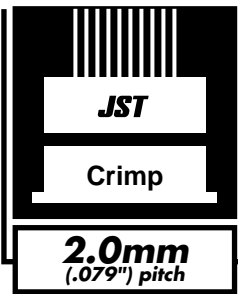

# PHD CONNECTOR

*Disconnectable Crimp style connectors*



***This is a 2.0mm (.079") pitch, crimp style, double-row, wire-to-board connector. It is designed to meet the demand for high-density and low-profile connection.***

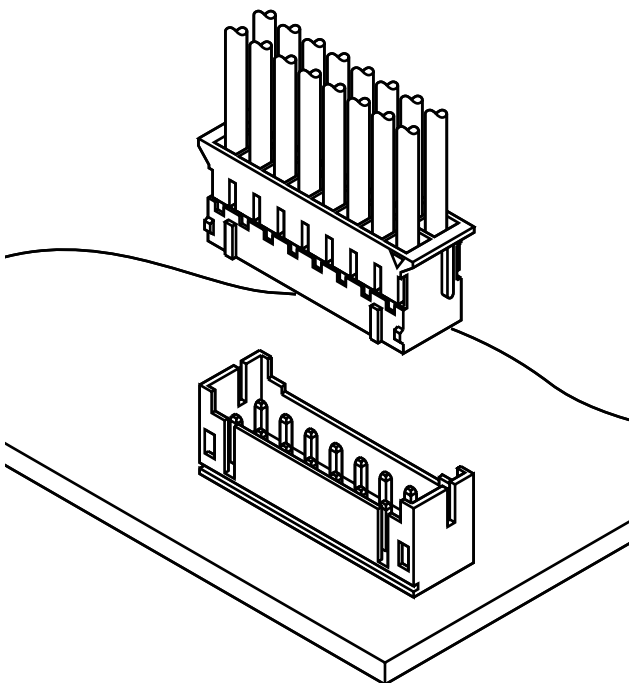

## Features

### • Compact

2.0mm (.079") pitch connector, 8.8mm (.346") in height after mounting and 5.0mm (.197") in width. This compact design meets the demand for high-density connection.

### • Reliable contacts

The box contact supplies stable contact performance even under conditions of vibration, distortion, low voltage or low current.

### • Fully shrouded header

The header is fully shrouded, having walls on all four sides to prevent improper mating and the intrusion of flux and other contaminants.

## Specifications

- Current rating: 3A AC, DC (AWG#22)
- Voltage rating: 250V AC, DC
- Temperature range: -25°C to +85°C  
(including temperature rise in applying electrical current)
- Contact resistance: Initial value/10m Ω max.  
After environmental testing/20m Ω max.
- Insulation resistance: 1,000M Ω min.
- Withstanding voltage: 800V AC/minute
- Applicable wire: AWG #28 to #22
- Applicable PC board thickness: 1.6mm(.063")
- \* Contact JST if Lead-Free product is required.
- \* Refer to "General Instruction and Notice when using Terminals and Connectors" at the end of this catalog.
- \* Contact JST for details.

## Standards

Ⓜ Recognized E60389

Ⓢ Certified LR20812

# PHD CONNECTOR

## Contact

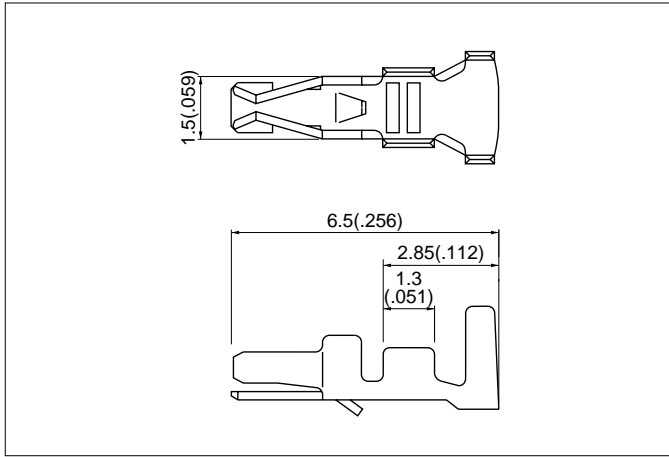

Model No.	Applicable wire			Q'ty / reel
	mm <sup>2</sup>	AWG #	Insulation O.D. mm(in.)	
<b>SPHD-002T-P0.5</b>	0.08 to 0.21	28 to 24	0.9 to 1.5(.035 to .059)	8,000
<b>SPHD-001T-P0.5</b>	0.13 to 0.33	26 to 22	1.0 to 1.5(.039 to .059)	

### Material and Finish

Phosphor bronze, tin-plated

## Housing

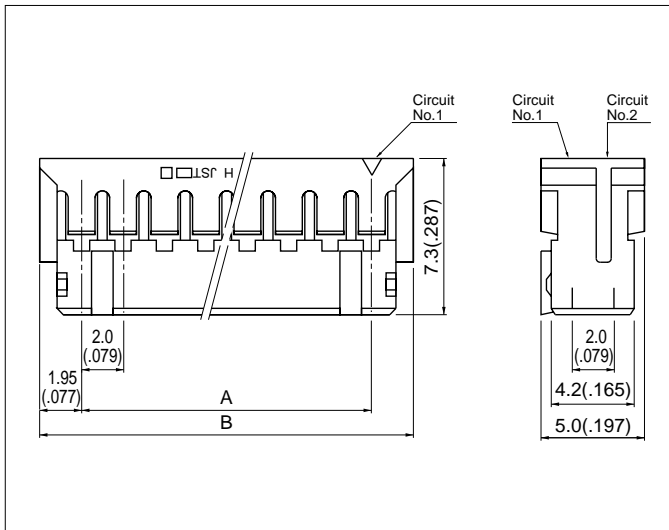

Circuits	Model No.	Dimensions mm(in.)		Q'ty / bag
		A	B	
8	<b>PHDR-08VS</b>	6.0( .236)	9.9( .390)	1,000
10	<b>PHDR-10VS</b>	8.0( .315)	11.9( .469)	1,000
12	<b>PHDR-12VS</b>	10.0( .394)	13.9( .547)	1,000
14	<b>PHDR-14VS</b>	12.0( .472)	15.9( .626)	1,000
16	<b>PHDR-16VS</b>	14.0( .551)	17.9( .705)	1,000
18	<b>PHDR-18VS</b>	16.0( .630)	19.9( .783)	1,000
20	<b>PHDR-20VS</b>	18.0( .709)	21.9( .862)	1,000
22	<b>PHDR-22VS</b>	20.0( .787)	23.9( .941)	1,000
24	<b>PHDR-24VS</b>	22.0( .866)	25.9(1.020)	1,000
26	<b>PHDR-26VS</b>	24.0( .945)	27.9(1.098)	1,000
28	<b>PHDR-28VS</b>	26.0(1.024)	29.9(1.177)	1,000
30	<b>PHDR-30VS</b>	28.0(1.102)	31.9(1.256)	1,000
32	<b>PHDR-32VS</b>	30.0(1.181)	33.9(1.335)	1,000
34	<b>PHDR-34VS</b>	32.0(1.260)	35.9(1.413)	1,000

### Material

Nylon 66, UL94V-0, natural (white)

<For reference> As the color identification, the following alphabet shall be put in the underlined part. For availability, delivery and minimum order quantity, contact JST.

ex. **PHDR-10VS**  
 S...natural (white)  
 K...black Y...yellow E...blue R...red

## Shrouded header

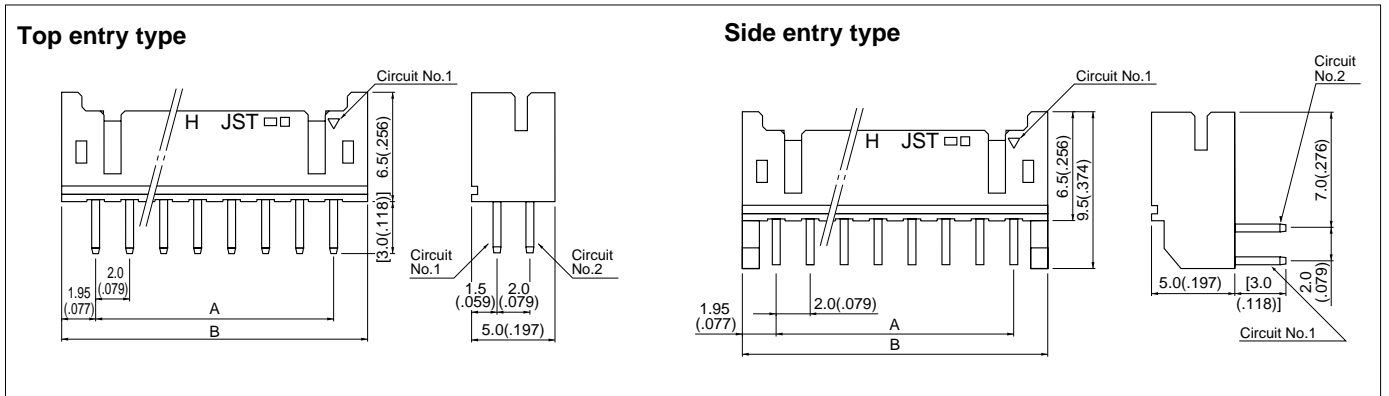

Circuits	Model No.				Dimensions mm(in.)		Q'ty / box	
	Glass-filled nylon		Nylon		A	B	Top entry type	Side entry type
	Top entry type	Side entry type	Top entry type	Side entry type				
8	<b>B 8B-PHDSS</b>	<b>S 8B-PHDSS</b>	-	-	6.0( .236)	9.9( .390)	-	500
10	<b>B10B-PHDSS</b>	<b>S10B-PHDSS</b>	<b>B10B-PHDSS-B</b>	<b>S10B-PHDSS-B</b>	8.0( .315)	11.9( .469)	500	500
12	<b>B12B-PHDSS</b>	<b>S12B-PHDSS</b>	<b>B12B-PHDSS-B</b>	<b>S12B-PHDSS-B</b>	10.0( .394)	13.9( .547)	500	500
14	<b>B14B-PHDSS</b>	<b>S14B-PHDSS</b>	<b>B14B-PHDSS-B</b>	<b>S14B-PHDSS-B</b>	12.0( .472)	15.9( .626)	500	250
16	<b>B16B-PHDSS</b>	<b>S16B-PHDSS</b>	<b>B16B-PHDSS-B</b>	<b>S16B-PHDSS-B</b>	14.0( .551)	17.9( .705)	500	250
18	<b>B18B-PHDSS</b>	<b>S18B-PHDSS</b>	<b>B18B-PHDSS-B</b>	<b>S18B-PHDSS-B</b>	16.0( .630)	19.9( .783)	500	250
20	<b>B20B-PHDSS</b>	<b>S20B-PHDSS</b>	<b>B20B-PHDSS-B</b>	<b>S20B-PHDSS-B</b>	18.0( .709)	21.9( .862)	250	250
22	<b>B22B-PHDSS</b>	<b>S22B-PHDSS</b>	<b>B22B-PHDSS-B</b>	<b>S22B-PHDSS-B</b>	20.0( .787)	23.9( .941)	250	250
24	<b>B24B-PHDSS</b>	<b>S24B-PHDSS</b>	<b>B24B-PHDSS-B</b>	<b>S24B-PHDSS-B</b>	22.0( .866)	25.9(1.020)	250	200
26	<b>B26B-PHDSS</b>	<b>S26B-PHDSS</b>	<b>B26B-PHDSS-B</b>	<b>S26B-PHDSS-B</b>	24.0( .945)	27.9(1.098)	250	200
28	<b>B28B-PHDSS</b>	<b>S28B-PHDSS</b>	<b>B28B-PHDSS-B</b>	<b>S28B-PHDSS-B</b>	26.0(1.024)	29.9(1.177)	250	200
30	<b>B30B-PHDSS</b>	<b>S30B-PHDSS</b>	<b>B30B-PHDSS-B</b>	<b>S30B-PHDSS-B</b>	28.0(1.102)	31.9(1.256)	250	200
32	<b>B32B-PHDSS</b>	<b>S32B-PHDSS</b>	<b>B32B-PHDSS-B</b>	<b>S32B-PHDSS-B</b>	30.0(1.181)	33.9(1.335)	250	200
34	<b>B34B-PHDSS</b>	<b>S34B-PHDSS</b>	<b>B34B-PHDSS-B</b>	<b>S34B-PHDSS-B</b>	32.0(1.260)	35.9(1.413)	250	200

### Material and Finish

Post: Copper alloy, copper-undercoated, tin/lead-plated  
 Wafer: Glass-filled nylon 66, UL94V-0, natural (ivory)  
 Nylon 66, UL94V-0, natural (white)

<For reference> As the color identification, the following alphabet shall be put in the underlined part. For availability, delivery and minimum order quantity, contact JST.

ex. **B10B-PHDSS**

S...natural (ivory)

ex. **B10B-PHDSS-B**

S...natural (white)

K...black Y...yellow E...blue R...red

# PHD CONNECTOR

## PC board layout (viewed from soldering side) and Assembly layout

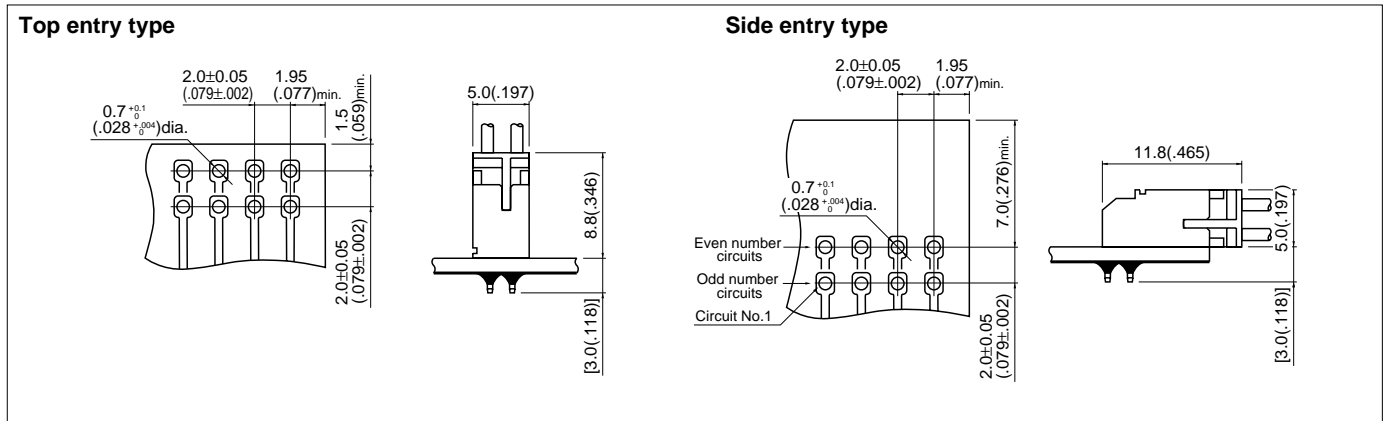

- Note:
1. Tolerances are non-cumulative:  $\pm 0.05$  mm ( $\pm .002$ ") for all centers.
  2. Hole dimensions differ according to the kind of PC board and piercing method. If printed circuit boards made of hard material are used, the hole dimensions should be larger. The dimensions above should serve as a guideline. Contact JST for details.

## Applicator for the semi-automatic press AP-K2N

Contact	Crimp applicator MKS-L-10		Compact crimp applicator MKS-LS-10		Strip-crimp applicator MKS-SC-10
	with safety cover	without safety cover	with safety cover	without safety cover	with safety cover
SPHD-001T-P0.5	APLMK SPHD001-05	APLNC SPHD001-05	APLMKLS SPHD001-05	APLLSNC SPHD001-05	APLSC SPHD001-05
SPHD-002T-P0.5	APLMK SPHD002-05	APLNC SPHD002-05	APLMKLS SPHD002-05	APLLSNC SPHD002-05	APLSC SPHD002-05