

## 阅读申明

- 1.本站收集的数据手册和产品资料都来自互联网，版权归原作者所有。如读者和版权方有任何异议请及时告之，我们将妥善解决。
- 2.本站提供的中文数据手册是英文数据手册的中文翻译，其目的是协助用户阅读，该译文无法自动跟随原稿更新，同时也可能存在翻译上的不当。建议读者以英文原稿为参考以便获得更精准的信息。
- 3.本站提供的产品资料，来自厂商的技术支持或者使用者的心得体会等，其内容可能存在描述上的差异，建议读者做出适当判断。
- 4.如需与我们联系，请发邮件到marketing@iczoom.com，主题请标有“数据手册”字样。

## Read Statement

1. The datasheets and other product information on the site are all from network reference or other public materials, and the copyright belongs to the original author and original published source. If readers and copyright owners have any objections, please contact us and we will deal with it in a timely manner.
2. The Chinese datasheets provided on the website is a Chinese translation of the English datasheets. Its purpose is for reader's learning exchange only and do not involve commercial purposes. The translation cannot be automatically updated with the original manuscript, and there may also be improper translations. Readers are advised to use the English manuscript as a reference for more accurate information.
3. All product information provided on the website refer to solutions from manufacturers' technical support or users the contents may have differences in description, and readers are advised to take the original article as the standard.
4. If you have any questions, please contact us at marketing@iczoom.com and mark the subject with "Datasheets" .

# 1 mm Pitch Double Rows Low Profile Board-to-Cable Connectors

## DF20 series

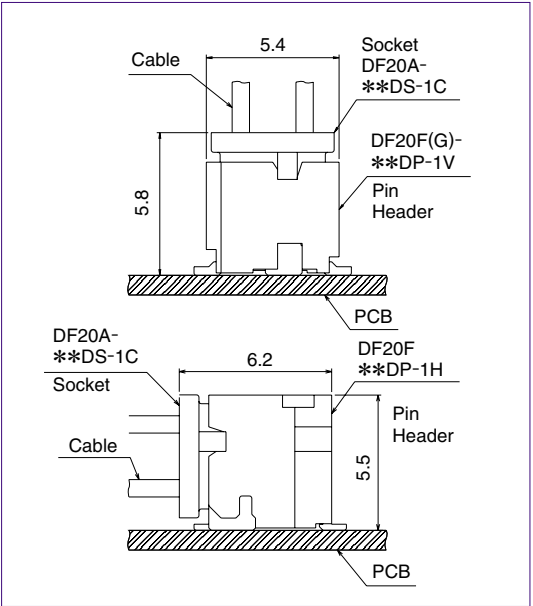

### ■ Features

#### 1. Contact Pitch

1 mm contact pitch allows reliable solder and cable termination.

#### 2. Low profile

Total mating height above the board is 5.8 mm for the straight type and 5.5 mm for the right angle type.

#### 3. Reliable electrical connection wipe

Effective electrical connection is assured with a 1mm wipe of mating contacts.

#### 4. Narrower external width and length

Redesigned metal fittings decreased the overall length of the board-mount receptacle and permit end-to-end mounting of several connectors.

#### 5. Automatic equipment board placement

Straight type pin headers are supplied with a 5.4 mm X 4.6mm flat platform to allow vacuum pick-up and placement on the board.

#### 6. Product variations

- (1) Available with 10, 20, 30, 40, and 50 contacts.
- (2) Pin headers are available in two types: with or without board positioning bosses.
- (3) Depending on specific application pin headers can be ordered in straight or right angle types.

### Narrower external width and length

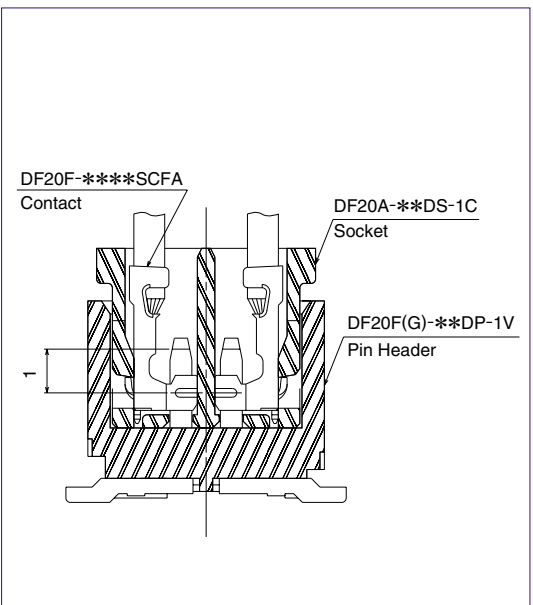
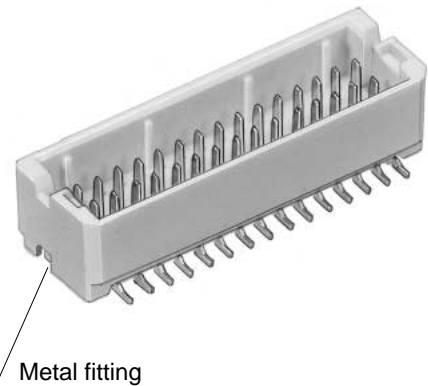

### ■ Applications

Notebook PC, small office automation equipment, small consumer devices, portable devices.

Any application requiring low profile reliable board-to-cable connection with a AWG #28, AWG#30, AWG#32 conductors.

#### 1mm Pitch, Double Rows



## Product Specifications

|        |               |   |                             |                          |                           |                        |
|--------|---------------|---|-----------------------------|--------------------------|---------------------------|------------------------|
| Rating | Rated current | AWG#28 : 1A<br>AWG#30 : 0.9A<br>AWG#32 : 0.7A | Operating temperature range | -35°C to 85°C (Note 1,2) | Storage temperature range | -10°C to 60°C (Note 2) |
|        | Rated voltage | 100V AC                                       | Operating humidity range    | 20% to 80%               | Storage humidity range    | 40% to 70%             |

| Item  | Specifications   | Conditions   |
|---|--|--|
| 1. Insulation resistance                    | 500MΩ min.   | Measured at 100V DC  |
| 2. Withstanding voltage                     | No flashover or insulation breakdown                                 | Conduction of 300V AC applied for 1 minute   |
| 3. Contact resistance                       | 30mΩ max.  | Measure at 100mA.  |
| 4. Insertion-Extraction force (per contact) | Min. 0.2 N (20 gf), Max. 2 N (200 gf)                                | Measured with a steel pin of 0.2 ±0.005 thickness  |
| 5. Vibration                                | No electrical discontinuity of 1μs min.                              | Frequency of 10 to 55 Hz, single amplitude of 0.75 mm, in 3 directions for 2hours                                |
| 6. Humidity                                 | Contact resistance of 30mΩ max., insulation resistance of 100MΩ min. | Temperature of 40±2°C, humidity of 90% to 95%, left standing for 96 hours  |
| 7. Temperature cycle                        | Contact resistance of 30mΩ max., insulation resistance of 500MΩ min. | (-55°C:30min → 5°C to 35°C: 2 to 3min → 85°C:30min → 5°C to 35°C:2 to 3min ) for 5 cycles                        |
| 8. Mechanical operation                     | Contact resistance of 30mΩ max.                                      | 50 cycles  |
| 9. Resistance to Soldering heat             | No deformation of the insulator parts that will affect performance   | Reflow: At the recommended temperature profile, manual solder: Soldering iron temperature of 300°C for 3 seconds |

Note1: Includes temperature rise caused by current flow.

Note2: The term "storage" refers to products stored for long periods of time prior to mounting and use.

Operating temperature range and Humidity range covers non-conducting conditions of installed connectors in storage, shipment or transportation.

## Materials

| Item           | Part          | Material        | Finish   | Remarks |
|----------------|---------------|-----------------|--|---------|
| Socket         | Insulator     | Polyamide       | Color : Beige  | UL94V-0 |
| Socket contact | Contact       | Phosphor bronze | Gold plating   | —       |
| Pin header     | Insulator     | Polyamide       | Color : Beige  | UL94V-0 |
|                | Contact       | Phosphor bronze | Gold plating   | —       |
|                | Metal Fitting | Brass           | V type: Solder plating<br>H type: Tin-Copper plating (Pb free) |         |

## Ordering Information

### Connectors

**DF 20 # - \* DS - 1 C**

① ② ③ ④ ⑤ ⑥ ⑦

|   |  |
|---|--|
| ① Series name : DF  | ⑤ Connector type<br>DS: Double-row socket<br>DP: Double-row pin header                               |
| ② Series No. : 20   | ⑥ Contact pitch: 1 mm  |
| ③ Boss Type<br>■ Pin header<br>F: Without boss<br>G: With boss<br>■ Crimp socket: A | ⑦ Type of housing, header<br>C: Crimp housing<br>V: Straight SMT header<br>H: Right angle SMT header |
| ④ Number of contacts: 10, 20, 30, 40, 50  |  |

### Contacts

**DF20 F - 2830 SCF A (\* \*)**

① ② ③ ④ ⑤

|  |  |   |
|--|--|---|
| ① F  | ③ Contact & packaging type<br>SCF: Socket contact reel | ⑤ Packaging Specifications<br>Blank: 1 reel = 10,000 pieces<br>41: 1 reel = 20,000 pieces |
| ② Applicable wire size<br>2830: AWG #28 to 30<br>3032: AWG #30 to 32 | ④ Plating type<br>A: Gold plating                      |   |

## Double Row Socket

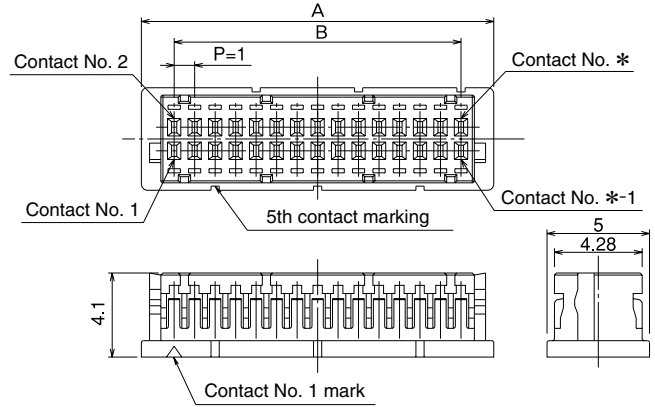

Unit: mm

| Product No.   | CL No.     | Number of Contacts | A    | B    |
|---------------|------------|--------------------|------|------|
| DF20A-10DS-1C | 686-0020-3 | 10                 | 7.2  | 4.0  |
| DF20A-20DS-1C | 686-0021-6 | 20                 | 12.2 | 9.0  |
| DF20A-30DS-1C | 686-0022-9 | 30                 | 17.2 | 14.0 |
| DF20A-40DS-1C | 686-0023-1 | 40                 | 22.2 | 19.0 |
| DF20A-50DS-1C | 686-0024-4 | 50                 | 27.2 | 24.0 |

[Specifications number]-\*, (\*\*)  
(59): Gold plating, embossed tape packaging

Note: Sales quantities are by the package unit (containing 100 pieces). Please order by package unit.

## Socket Crimp Contacts

| Product No.        | CL No.         | Type of contacts | Quantity                         | Plating type |
|--------------------|----------------|------------------|----------------------------------|--------------|
| DF20F-2830SCFA(**) | 686-0042-6-*** | Reel contacts    | See specifications number column | Gold plating |
| DF20F-3032SCFA(**) | 686-0043-9-*** |                  |                                  |              |

[Specifications number] -, (\*\*)  
Blank 1 reel : 10,000 pieces  
41 1 reel : 20,000 pieces

### ●Applicable Wire (Tin plated solid soft conductor)

| Applicable Wire Size (Stranded wire conductor) | Jacket diameter |
|--|-----------------|
| AWG #28 (7/0.127 mm)                           | 0.5mm to 0.6 mm |
| AWG #30 (7/0.1 mm)                             |                 |
| AWG #32 (7/0.08 mm)                            |                 |

●Recommended wire      ●Strip length  
UL1571                              1.2 to 1.9 mm

Note: When using other than the recommended wire, contact your nearest Hirose representative.

### ●Applicable Crimping Tools

| Type                 | CL No.     | Product No.       |
|----------------------|------------|-------------------|
| Applicator           | 901-4572-6 | AP105-DF20-2830S  |
| Press                | 901-0005-4 | CM-105            |
| Manual crimping tool | 901-4540-6 | HT302/DF20B-2830S |

Note 1: Hirose Electric will not be responsible for any problems caused by use of tools other than specified.

Note 2: The manual crimping tool can be also used for cutting-off individual contacts from the reel.

Note 3: Customers that already have DF13 Series Hirose's press units and applicators will be able to use them for DF20 Series crimp terminations by replacing of only crimper and anvil.

Note4: The crimping tool for the DF20F-3032SCFA can also be used with the DF20F-2830SCFA.

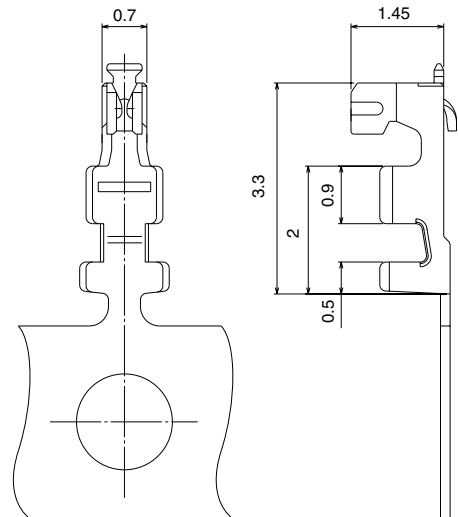

## Replacement Parts List for Applicator

| Type                            | Product No.          | CL No.        |
|---------------------------------|----------------------|---------------|
| Insulation crimper              | AP105-DF20-2830S(61) | 901-4572-6-61 |
| Wire crimper                    | AP105-DF20-2830S(62) | 901-4572-6-62 |
| Insulation anvil and wire anvil | AP105-DF20-2830S(63) | 901-4572-6-63 |

## Double Row Straight Pin header

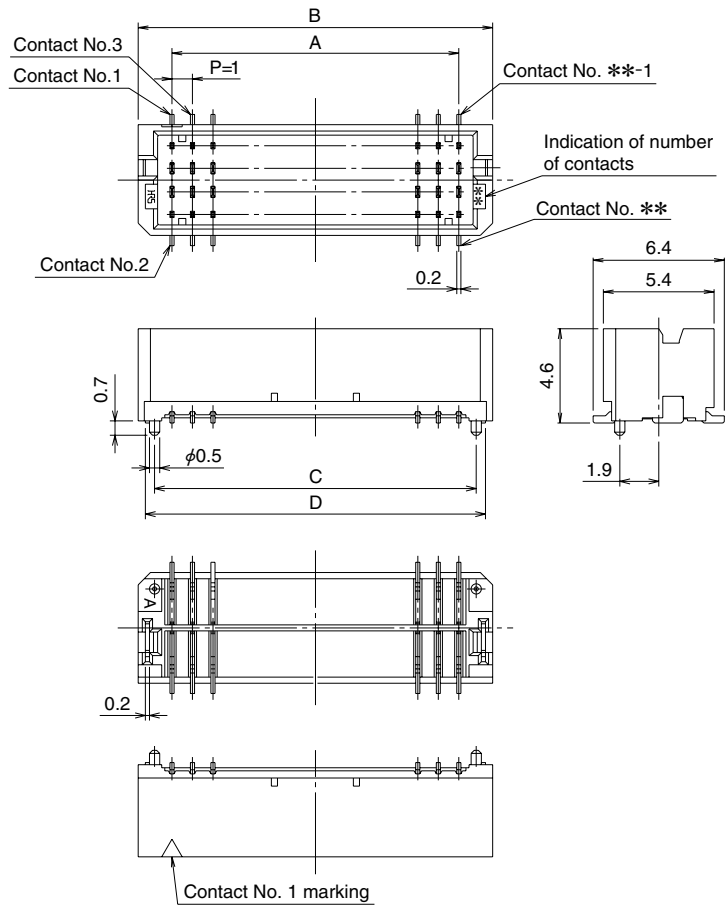
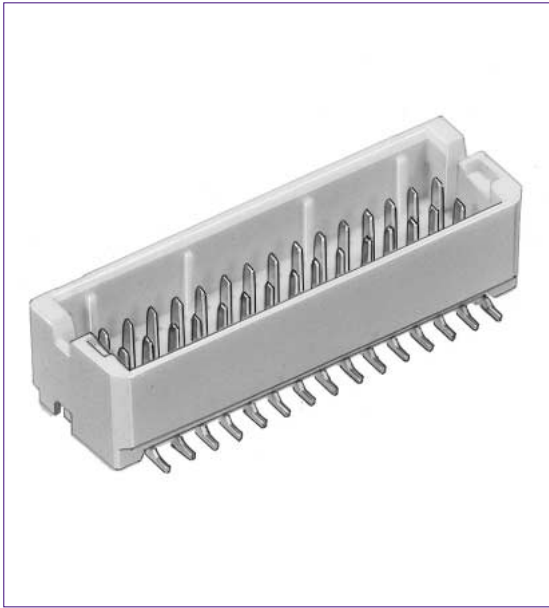

## PCB Footprints

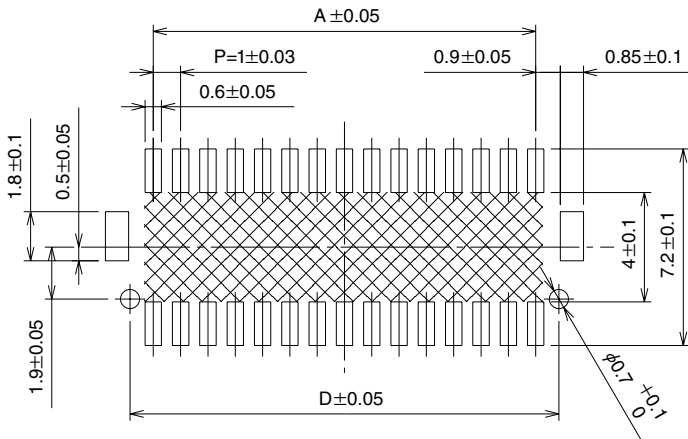

Note 1: Shaded area must be free of any electrically conductive traces to avoid contact with soldered pin header terminations.

Note 2: Required only for pin headers supplied with the positioning boss.

Unit: mm

| Product No.        | CL No.           | Number of contacts | A    | B    | C    | D    | Remarks      |
|--------------------|------------------|--------------------|------|------|------|------|--------------|
| DF20F-10DP-1V (**) | CL686-0032-2- ** | 10                 | 4.0  | 7.3  | —    | 5.7  | Without boss |
| DF20F-20DP-1V (**) | CL686-0033-5- ** | 20                 | 9.0  | 12.3 | —    | 10.7 |              |
| DF20F-30DP-1V (**) | CL686-0034-8- ** | 30                 | 14.0 | 17.3 | —    | 15.7 |              |
| DF20F-40DP-1V (**) | CL686-0035-0- ** | 40                 | 19.0 | 22.3 | —    | 20.7 |              |
| DF20F-50DP-1V (**) | CL686-0036-3- ** | 50                 | 24.0 | 27.3 | —    | 25.7 |              |
| DF20G-10DP-1V (**) | CL686-0037-6- ** | 10                 | 4.0  | 7.3  | 6.6  | 5.7  | With boss    |
| DF20G-20DP-1V (**) | CL686-0038-9- ** | 20                 | 9.0  | 12.3 | 11.6 | 10.7 |              |
| DF20G-30DP-1V (**) | CL686-0039-1- ** | 30                 | 14.0 | 17.3 | 16.6 | 15.7 |              |
| DF20G-40DP-1V (**) | CL686-0040-0- ** | 40                 | 19.0 | 22.3 | 21.6 | 20.7 |              |
| DF20G-50DP-1V (**) | CL686-0041-3- ** | 50                 | 24.0 | 27.3 | 26.6 | 25.7 |              |

Note1: Order embossed tape packaging items by the reel. (1 reel contains 1,000 pieces)

Note2: Vacuum pick-up platforms are included with embossed tape packaged connectors.

[Specifications number]-\*, (\*\*)  
(59): Gold plating, embossed tape packaging

## Double Row Right angle Pin header

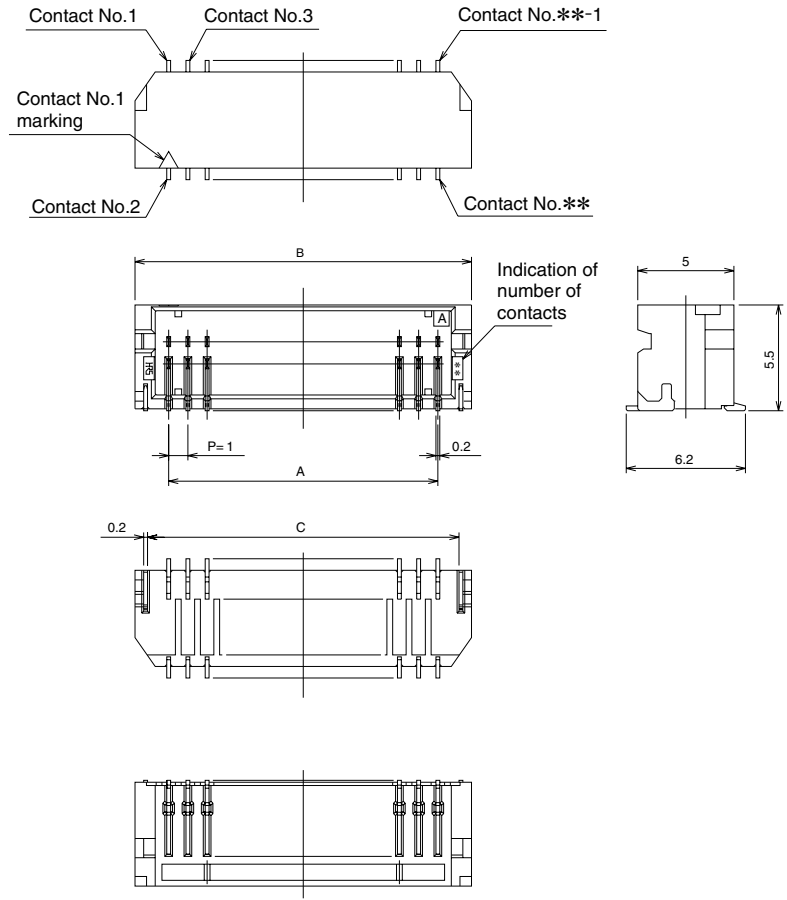

## PCB Footprints

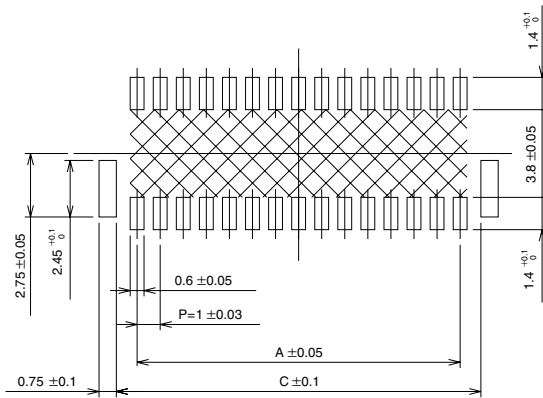

Note : Shaded area must be free of any electrically conductive traces to avoid contact with soldered pin header terminations.

Unit: mm

| Product No.           | HRS No.                        | Number of contacts | A    | B    | C    | Remarks      |
|-----------------------|--------------------------------|--------------------|------|------|------|--------------|
| DF20F -10DP-1H ( ** ) | 686-0027-2 ( ** )              | 10                 | 4.0  | 7.5  | 6.2  | Without boss |
| DF20F -20DP-1H ( ** ) | 686-0028-5 ( ** )              | 20                 | 9.0  | 12.5 | 11.2 |              |
| DF20F -30DP-1H ( ** ) | 686-0029-8 ( ** )              | 30                 | 14.0 | 17.5 | 16.2 |              |
| DF20F -40DP-1H ( ** ) | Reserved for product expansion | 40                 | 19.0 | 22.5 | 21.2 |              |
| DF20F -50DP-1H ( ** ) | Reserved for product expansion | 50                 | 24.0 | 27.5 | 26.2 |              |

[Specifications number]-\*, (\*\*)  
(59): Gold plating,  
embossed tape packaging

Note: Order embossed tape packaging items by the reel. (1 reel contains 1,000 pieces)

## ◆ Embossed Carrier Tape Dimensions

### ● Straight pin header

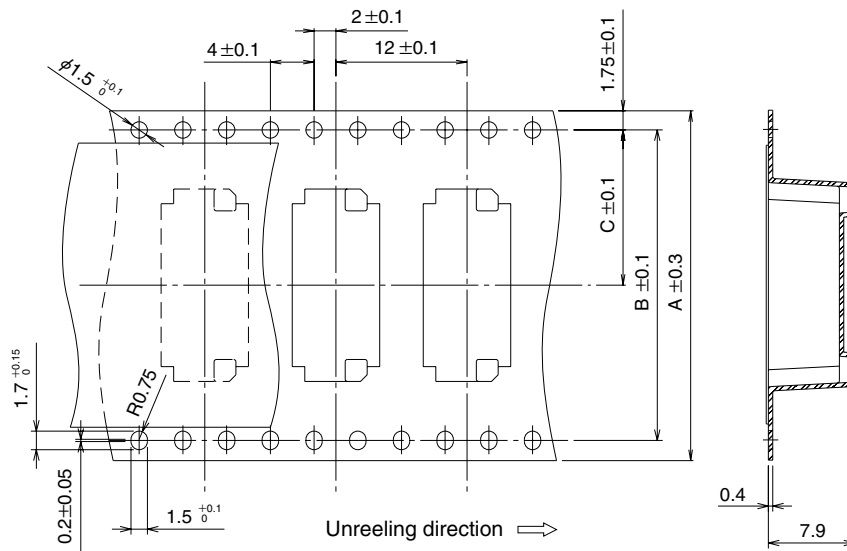

### ● Right angle pin header

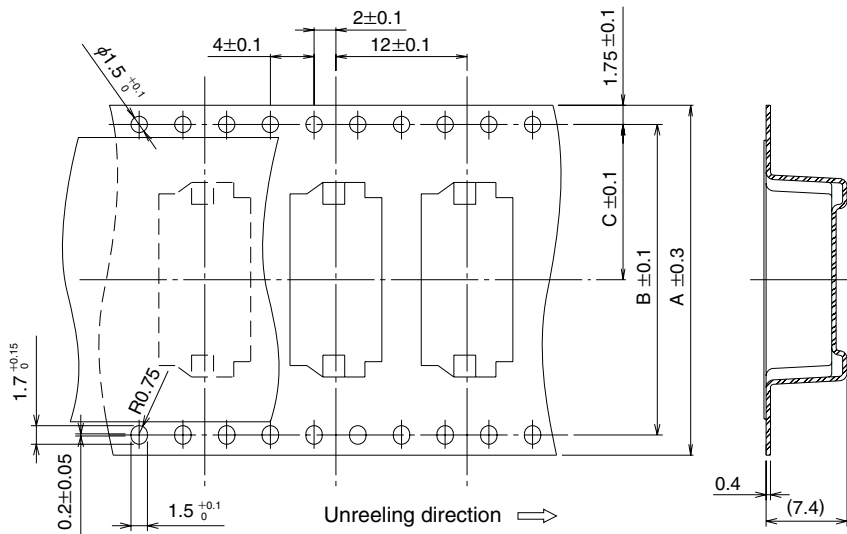

### ● Reel dimensions

| Product No.      | Number of Contacts | A  | B    | C    | D    |
|------------------|--------------------|----|------|------|------|
| DF20F(G)-10DP-1V | 10                 | 16 | —    | 7.5  | 16.4 |
| DF20F(G)-20DP-1V | 20                 | 24 | —    | 11.5 | 24.4 |
| DF20F(G)-30DP-1V | 30                 | 32 | 28.4 | 14.2 | 32.4 |
| DF20F(G)-40DP-1V | 40                 | 44 | 40.4 | 20.2 | 44.4 |
| DF20F(G)-50DP-1V | 50                 | 44 | 40.4 | 20.2 | 44.4 |
| DF20F-10DP-1H    | 10                 | 16 | —    | 7.5  | 16.4 |
| DF20F-20DP-1H    | 20                 | 24 | —    | 11.5 | 24.4 |
| DF20F-30DP-1H    | 30                 | 32 | 28.4 | 14.2 | 32.4 |
| * DF20F-40DP-1H  | 40                 | 44 | 40.4 | 20.2 | 44.4 |
| * DF20F-50DP-1H  | 50                 | 44 | 40.4 | 20.2 | 44.4 |

\* Reserved for product expansion

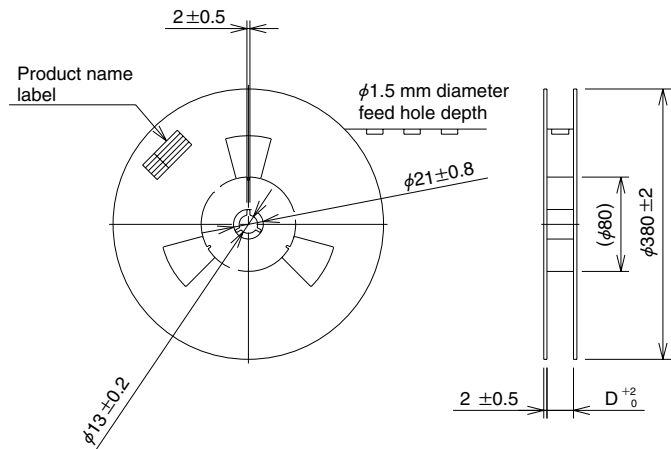

## ◆ Usage recommendation

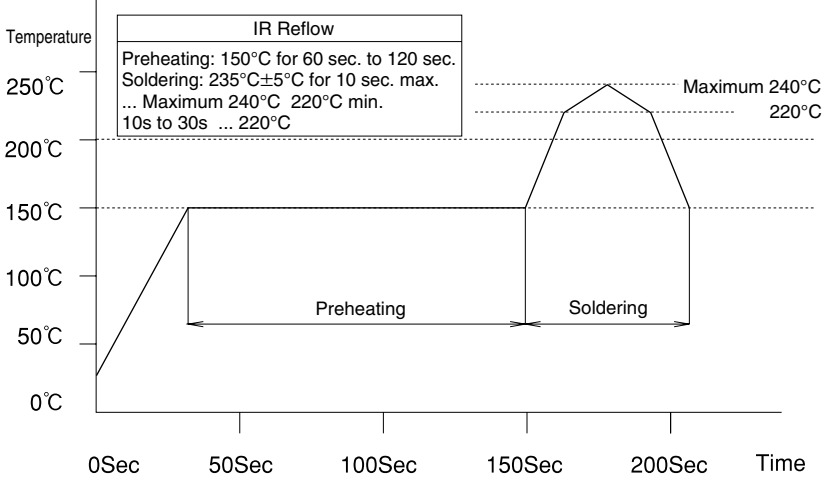
|  |   |
|--|---|
| <p>1. Recommended Soldering<br/>Temperature Profile for IR Reflow.</p> |  <p>Note 1: Up to 2 cycles of reflow soldering are possible under the same conditions, provided that there is a return to normal temperature between the first and second cycle.</p> <p>Note 2: The temperature indicates the board surface temperature at the points of contacts with the connector terminals.</p> |
| <p>2. Recommended Manual Soldering Conditions</p>                      | <p><b>Soldering temperature: 290°C ±10°C, Soldering time: within 3 sec.</b></p>   |
| <p>3. Recommended Solder Screen Thickness</p>                          | <p>0.15mm</p>   |
| <p>4. Board Warping</p>  | <p>Maximum of 0.03 mm at the connector center section, with both ends of the connector as reference points.</p>   |
| <p>5. Cleaning Conditions</p>  | <p>Refer to "Nylon Connector Use Handbook."</p>   |
| <p>6. Wiring Termination Conditions</p>                                | <p>Refer to "Nylon Connector Use Handbook."<br/>Crimp contacts should be handled with care as not to cause any deformation or damage affecting the performance or termination.</p>  |
| <p>7. Mating / un-mating precautions</p>                               | <p>Excessive twisting and pulling on wires during mating/un-mating should be avoided as it may cause damage to connectors.</p>  |