

阅读申明

- 1.本站收集的数据手册和产品资料都来自互联网，版权归原作者所有。如读者和版权方有任何异议请及时告之，我们将妥善解决。
- 2.本站提供的中文数据手册是英文数据手册的中文翻译，其目的是协助用户阅读，该译文无法自动跟随原稿更新，同时也可能存在翻译上的不当。建议读者以英文原稿为参考以便获得更精准的信息。
- 3.本站提供的产品资料，来自厂商的技术支持或者使用者的心得体会等，其内容可能存在描述上的差异，建议读者做出适当判断。
- 4.如需与我们联系，请发邮件到marketing@iczoom.com，主题请标有“数据手册”字样。

Read Statement

1. The datasheets and other product information on the site are all from network reference or other public materials, and the copyright belongs to the original author and original published source. If readers and copyright owners have any objections, please contact us and we will deal with it in a timely manner.
2. The Chinese datasheets provided on the website is a Chinese translation of the English datasheets. Its purpose is for reader's learning exchange only and do not involve commercial purposes. The translation cannot be automatically updated with the original manuscript, and there may also be improper translations. Readers are advised to use the English manuscript as a reference for more accurate information.
3. All product information provided on the website refer to solutions from manufacturers' technical support or users the contents may have differences in description, and readers are advised to take the original article as the standard.
4. If you have any questions, please contact us at marketing@iczoom.com and mark the subject with "Datasheets" .

REV	ECN	APP'D
-	3851	JEC 10-14-99
A	5461	SH 5-25-04
B	5742	RN 12/28/05

SM "SURFACE MOUNT" SERIES PART NUMBERING SCHEME

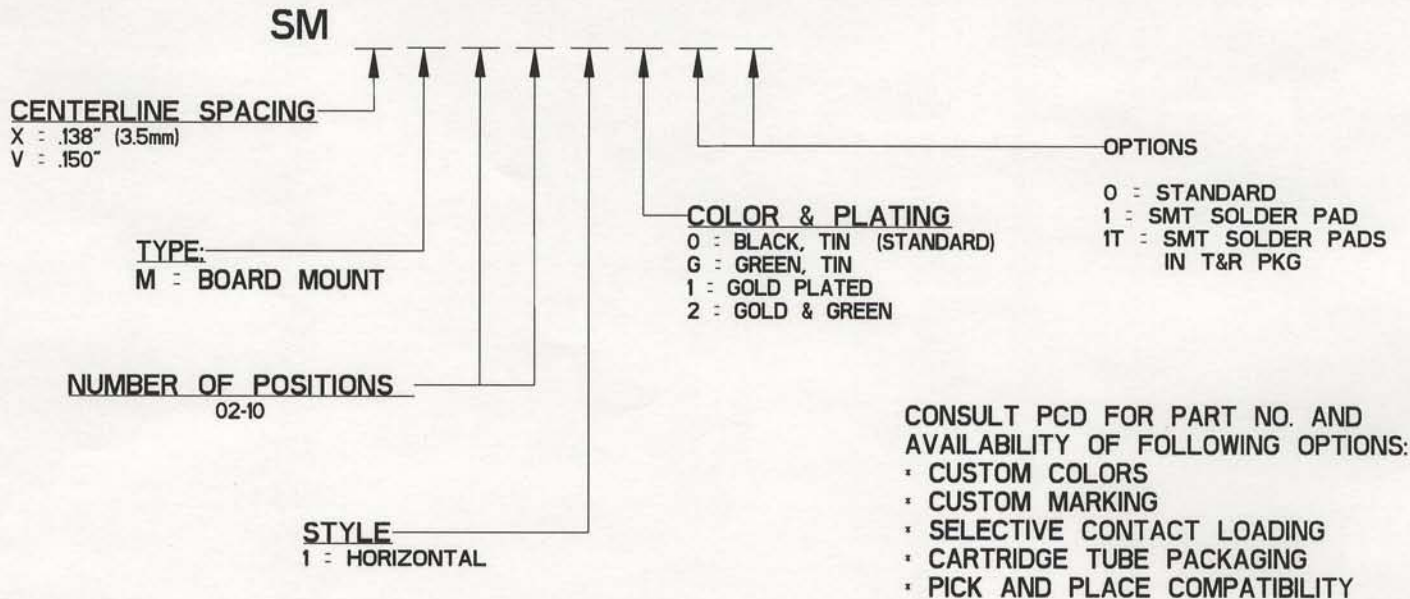

RATINGS
 CURRENT - 12A
 VOLTAGE - 300V
 U.L. FILE NO. E83421



RATINGS
 CURRENT - 12A
 VOLTAGE - 300V
 CSA FILE NO. LR69703

DIN VDE 0627:1986
 DIN VDE 0110-1:1989
 EN 60947-1:1991
 EN 60947-7-1:1992

CURRENT - PENDING
 VOLTAGE - PENDING
 TUV FILE NO. 20396

INSTALLATION RECOMMENDATIONS
 WIRE RANGE: AWG #16-28, STRANDED OR SOLID
 WIRE STRIP LENGTH: .250"
 TIGHTENING TORQUE: 2.2 LB-IN.

MATERIALS:
 HOUSING: PA 4/6, UL 94 V-0
 CONTACT: BRASS, OPTIONAL FINISH

MAX OPERATING TEMPERATURE: 125°C
 MAX INTRUSIVE SOLDER TEMP: 250°C

DIMENSIONS
 ANSI Y14.5M
 UNITS: INCHES
 Pro/E FILE

TOLERANCES
 .XX ±0.01
 .XXX ±0.005
 ANGLES ±2.0°

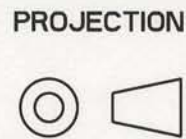

Amphenol Pcd

ENGR
 J. WILKINSON 9/17/99

CHKD
 A. PATRIE 10-14-99

APPD
 J. CAHALY 10-14-99

TITLE
 SMVM / SMXM
 SURFACE MOUNT CONNECTOR
 ASSEMBLY

ORIGINAL
 STAMPED
 IN RED

THIS DOCUMENT CONTAINS
 PROPRIETARY INFORMATION WHICH
 IS THE CONFIDENTIAL PROPERTY
 OF AMPHENOL PCD, INC.
 PEABODY, MA, USA

SIZE
A

DWG NO.
SMVM02100

REV
B

CODE: 58982

SCALE: NONE

SHEET 1 OF 3

PACKAGING

CARTRIDGE TUBES:
15.0" x 0.5" x 0.5"

TRAYS:
11.0" x 7.5" x 0.5"

TAPE & REEL:
44MM TAPE ON $\phi 13$ " REELS
250 PCS/REEL



MOUNTING SCREWS (2):
B 2.2 x 6.0 INCLUDED

SCALE 2:1

PART NO.	POS	DIM L $\pm .002/1N$	# OF PARTS IN TUBE	# OF PARTS IN TRAY
SMVM021XX	2	0.600	24	180
SMVM031XX	3	0.750	19	140
SMVM041XX	4	0.900	16	120
SMVM051XX	5	1.050	13	100
SMVM061XX	6	1.200	12	90
SMVM071XX	7	1.350	10	80
SMVM081XX	8	1.500	9	70
SMVM091XX	9	1.650	8	60
SMVM101XX	10	1.800	8	60
SMXM021XX	2	0.552	26	190
SMXM031XX	3	0.690	21	150
SMXM041XX	4	0.828	17	130
SMXM051XX	5	0.966	15	110
SMXM061XX	6	1.104	13	90
SMXM071XX	7	1.242	11	80
SMXM081XX	8	1.380	10	70
SMXM091XX	9	1.518	9	70
SMXM101XX	10	1.656	8	60

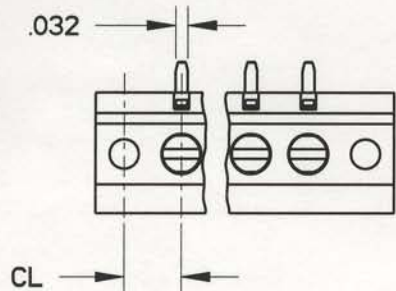

CL: V = .150", X = .138"

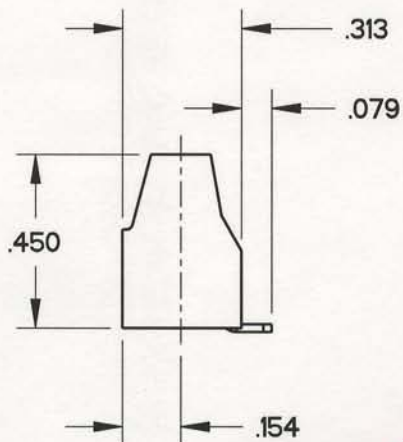
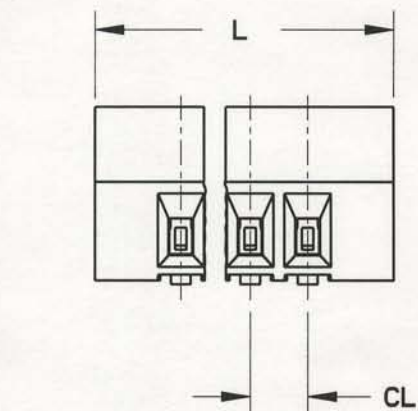

PRINTED CIRCUIT BOARD CONFIGURATION (THRUHOLE SCREW MOUNT OPTION)

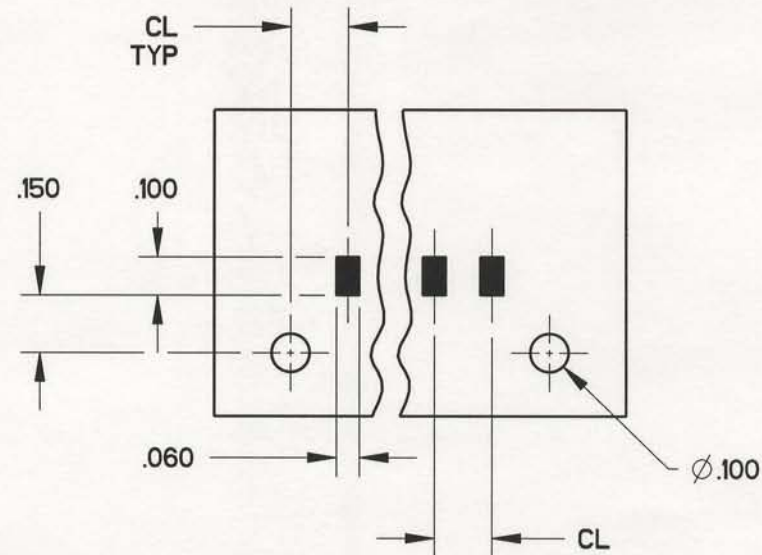

SIZE A	DWG NO. SMVM02100	REV B
CODE: 58982	SCALE: NONE	SHEET 2 OF 3

TAPE AND REEL PACKAGING (2, 3, AND 4 POS)



SCALE 3:10

NOTES:

1. COMPONENT ON 44MM CARRIER AND 13" REELS
2. 250 PCS PER 13" REEL
3. DISPOSABLE 5/16" SQ. POLYIMIDE TAPE FOR PICK AND PLACE

USER FEED DIR.

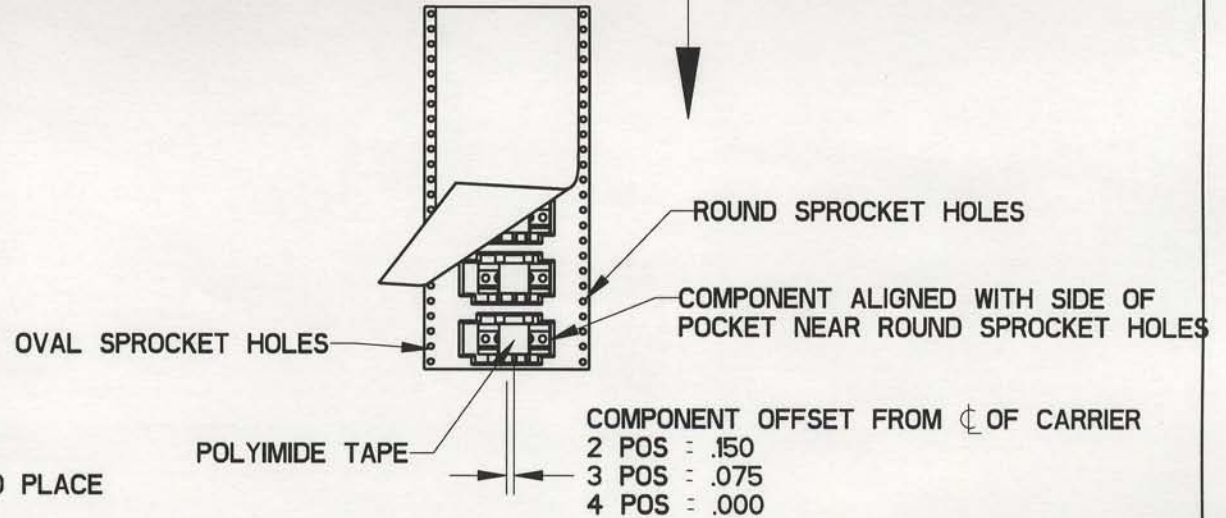

SMT PAD OPTION
(SMVM03101 SHOWN)

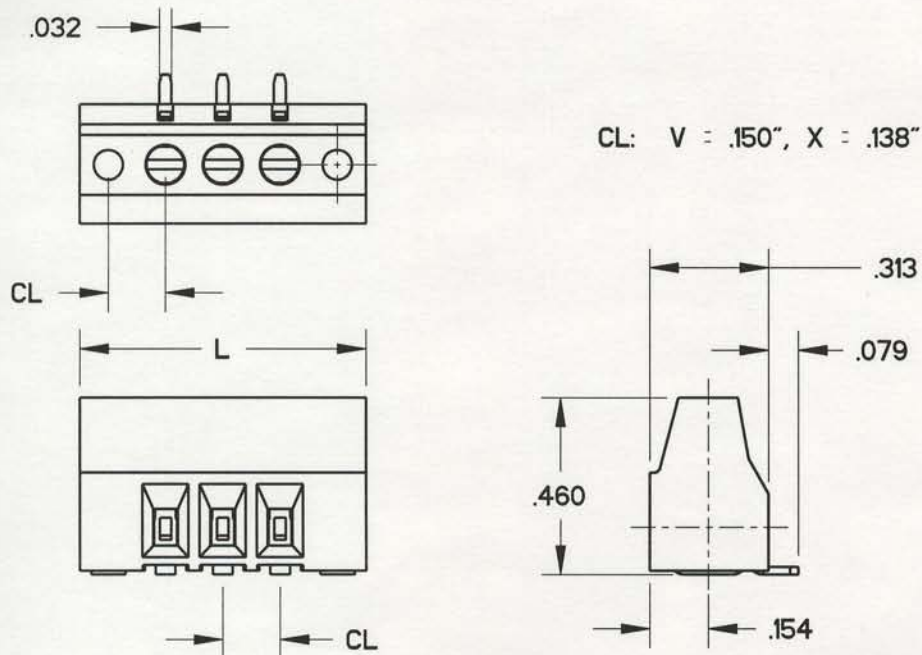

PRINTED CIRCUIT BOARD CONFIGURATION
(SMT PAD OPTION)

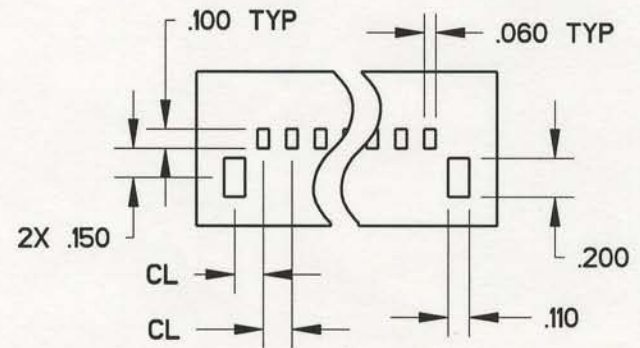

SIZE	DWG NO.	REV
A	SMVM02100	B
CODE: 58982	SCALE: NONE	SHEET 3 OF 3