

阅读申明

- 1.本站收集的数据手册和产品资料都来自互联网，版权归原作者所有。如读者和版权方有任何异议请及时告之，我们将妥善解决。
- 2.本站提供的中文数据手册是英文数据手册的中文翻译，其目的是协助用户阅读，该译文无法自动跟随原稿更新，同时也可能存在翻译上的不当。建议读者以英文原稿为参考以便获得更精准的信息。
- 3.本站提供的产品资料，来自厂商的技术支持或者使用者的心得体会等，其内容可能存在描述上的差异，建议读者做出适当判断。
- 4.如需与我们联系，请发邮件到marketing@iczoom.com，主题请标有“数据手册”字样。

Read Statement

1. The datasheets and other product information on the site are all from network reference or other public materials, and the copyright belongs to the original author and original published source. If readers and copyright owners have any objections, please contact us and we will deal with it in a timely manner.
2. The Chinese datasheets provided on the website is a Chinese translation of the English datasheets. Its purpose is for reader's learning exchange only and do not involve commercial purposes. The translation cannot be automatically updated with the original manuscript, and there may also be improper translations. Readers are advised to use the English manuscript as a reference for more accurate information.
3. All product information provided on the website refer to solutions from manufacturers' technical support or users the contents may have differences in description, and readers are advised to take the original article as the standard.
4. If you have any questions, please contact us at marketing@iczoom.com and mark the subject with "Datasheets" .

High Power Diode Modules

$$I_{FRSM} = 2x\ 480\ A$$

$$I_{FAVM} = 2x\ 305\ A$$

$$V_{RRM} = 1200-2200\ V$$

V_{RSM} V	V_{RRM} V	Type
1300	1200	MDD 310-12N1
1500	1400	MDD 310-14N1
1700	1600	MDD 310-16N1
1900	1800	MDD 310-18N1
2100	2000	MDD 310-20N1
2300	2200	MDD 310-22N1

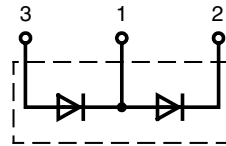

E72873

Symbol	Conditions	Maximum Ratings	
I_{FRMS}	$T_{VJ} = T_{VJM}$	480	A
I_{FAVM}	$T_C = 100^\circ C$; 180° sine	305	A
I_{FSM}	$T_{VJ} = 45^\circ C$; $t = 10\ ms$ (50 Hz)	11,5	kA
	$V_R = 0$; $t = 8.3\ ms$ (60 Hz)	12,2	kA
	$T_{VJ} = T_{VJM}$; $t = 10\ ms$ (50 Hz)	9,6	kA
	$V_R = 0$; $t = 8.3\ ms$ (60 Hz)	10,2	kA
I^2t	$T_{VJ} = 45^\circ C$; $t = 10\ ms$ (50 Hz)	662	kA ² s
	$V_R = 0$; $t = 8.3\ ms$ (60 Hz)	620	kA ² s
	$T_{VJ} = T_{VJM}$; $t = 10\ ms$ (50 Hz)	460	kA ² s
	$V_R = 0$; $t = 8.3\ ms$ (60 Hz)	430	kA ² s
T_{VJ}		-40...+150	°C
T_{VJM}		150	°C
T_{stg}		-40...+125	°C
V_{ISOL}	50/60 Hz, RMS $t = 1\ min$	3000	V~
	$I_{ISOL} \leq 1\ mA$ $t = 1\ s$	3600	V~
M_d	Mounting torque (M5)	2.5 - 5	Nm
	Terminal connection torque (M8)	12 - 15	Nm
Weight	Typical including screws	320	g

Features

- Direct copper bonded Al₂O₃ ceramic base plate
- Planar passivated chips
- Isolation voltage 3600 V~
- UL registered, E 72873

Applications

- Supplies for DC power equipment
- DC supply for PWM inverter
- Field supply for DC motors
- Battery DC power supplies

Advantages

- Space and weight savings
- Simple mounting
- Improved temperature and power cycling
- Reduced protection circuits

Symbol	Conditions	Characteristics Values	
I_{RRM}	$V_R = V_{RRM}$; $T_{VJ} = T_{VJM}$	40	mA
V_F	$I_F = 600\ A$; $T_{VJ} = 25^\circ C$	1.2	V
V_{T0}	For power-loss calculations only	0.75	V
r_t	$T_{VJ} = T_{VJM}$	0.63	mΩ
R_{thJC}	per diode; DC current	0.129	K/W
	per module <i>other values</i>	0.065	K/W
R_{thJK}	per diode; DC current <i>see Fig. 6/7</i>	0.169	K/W
	per module	0.0845	K/W
Q_S	$T_{VJ} = 125^\circ C$; $I_F = 400\ A$; $-di/dt = 50\ A/\mu s$	760	μC
I_{RM}		275	A
d_s	Creeping distance on surface	12.7	mm
d_A	Creepage distance in air	9.6	mm
a	Maximum allowable acceleration	50	m/s ²

Data according to IEC 60747 and refer to a single diode unless otherwise stated.

Dimensions in mm (1 mm = 0.0394")

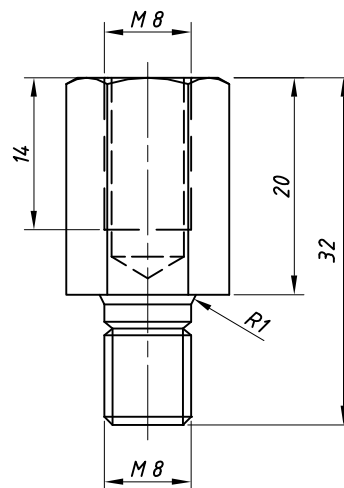
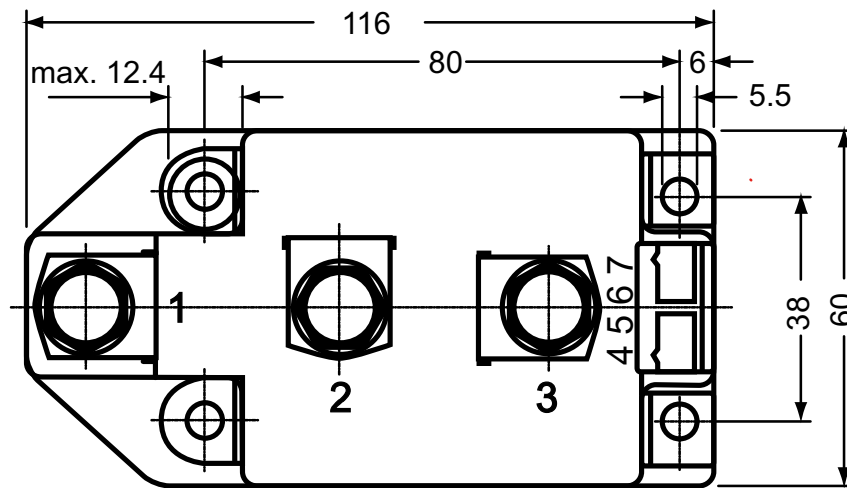
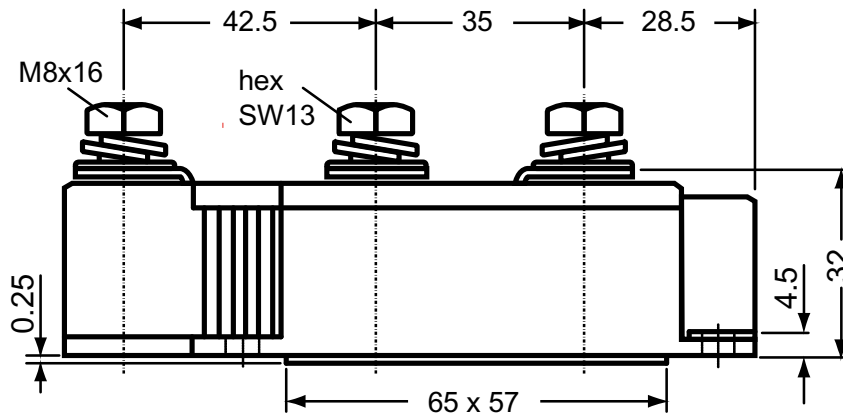

Threaded spacer for higher Anode / Cathode construction:

Type **ZY 250** (material brass)

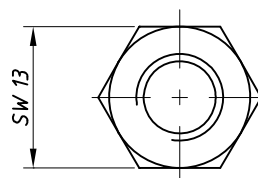

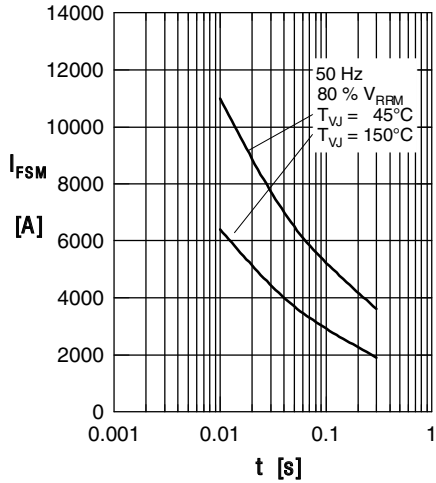

Fig. 1 Surge overload current
 I_{FSM} : Crest value, t : duration

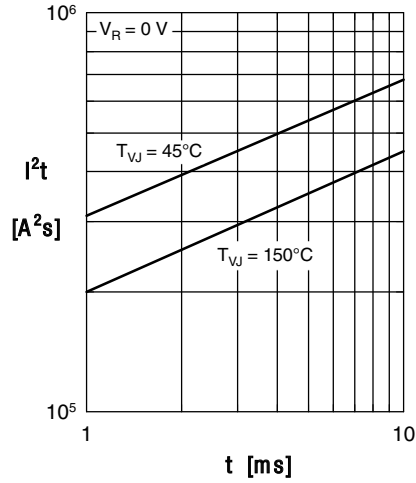

Fig. 2 I^2t versus time (1-10 ms)

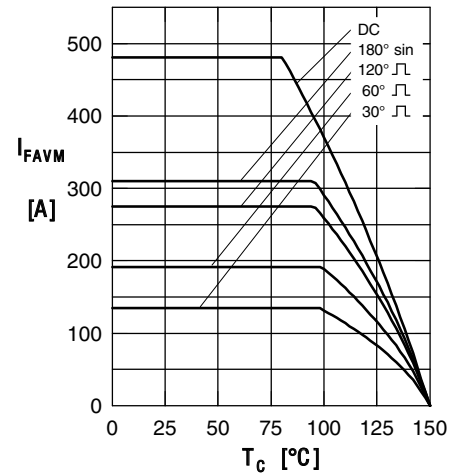

Fig. 3 Maximum forward current at case temperature

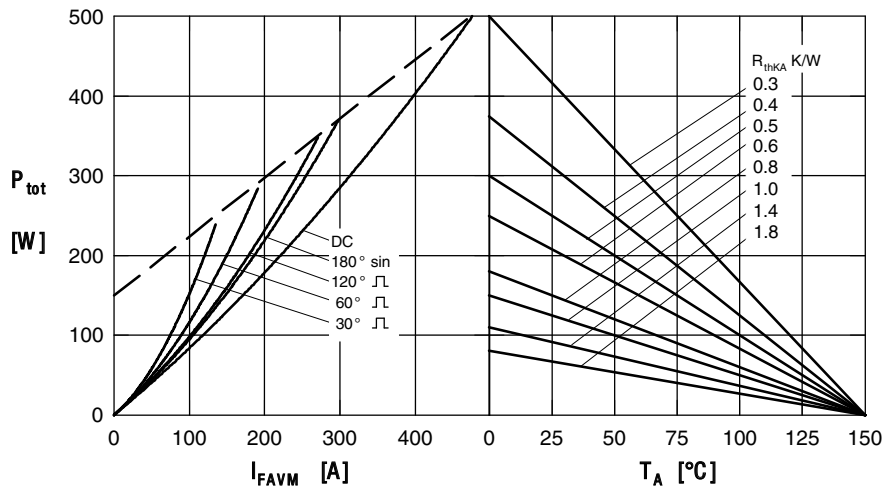

Fig. 4 Power dissipation versus forward current and ambient temperature (per diode)

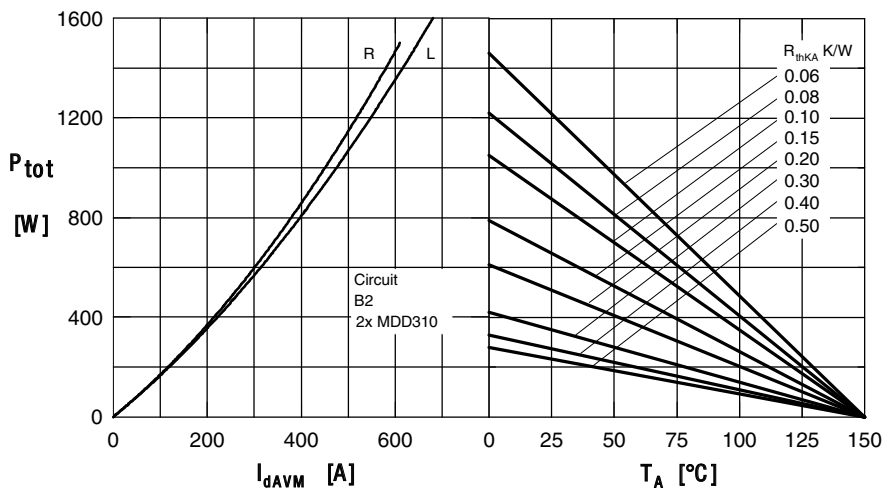

Fig. 5 Single phase rectifier bridge: Power dissipation vs. direct output current and ambient temperature R = resistive load, L = inductive load

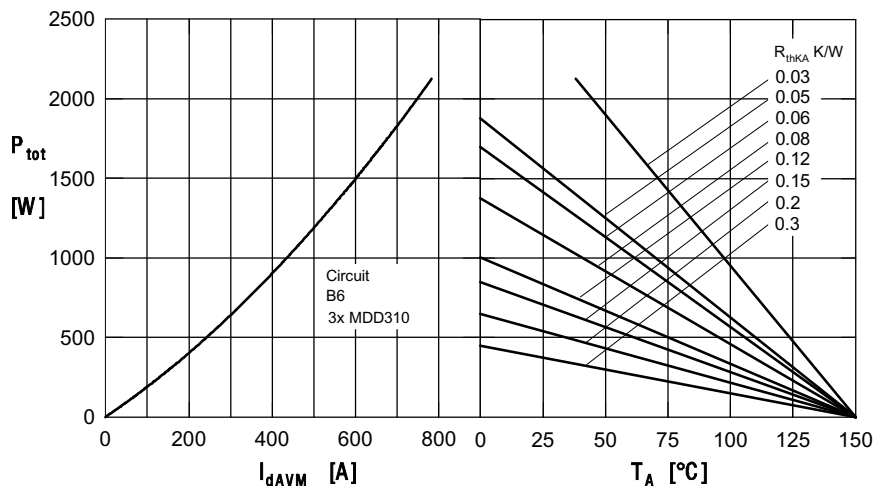

Fig.6 Three phase rectifier bridge: Power dissipation versus direct output current and ambient temperature

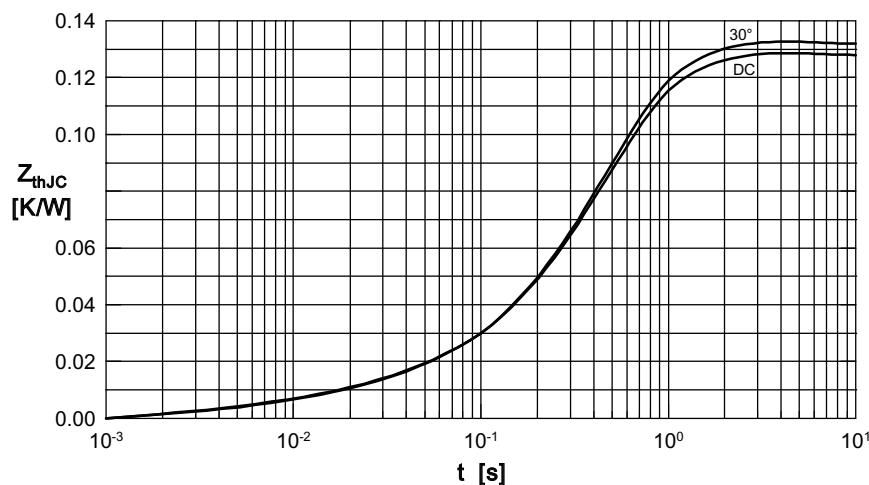

Fig. 7 Transient thermal impedance junction to case (per diode)

R_{thJC} for various conduction angles d :

d	R_{thJC} [K/W]
DC	0.129
180°	0.131
120°	0.132
60°	0.132
30°	0.133

Constants for Z_{thJC} calculation:

i	R_{thi} [K/W]	t_i [s]
1	0.0035	0.0099
2	0.0165	0.168
3	0.1091	0.456

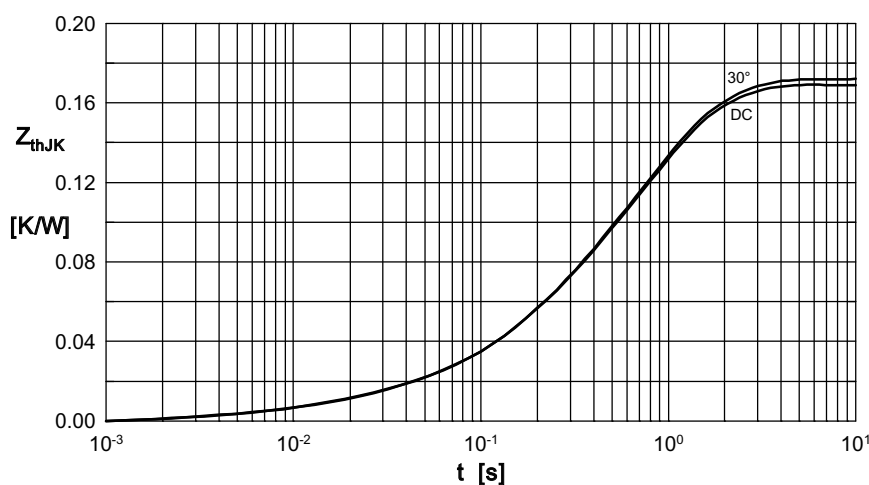

Fig. 8 Transient thermal impedance junction to heatsink (per diode)

R_{thJK} for various conduction angles d :

d	R_{thJK} (K/W)
DC	0.169
180°	0.171
120°	0.172
60°	0.172
30°	0.173

Constants for Z_{thJK} calculation:

i	R_{thi} (K/W)	t_i (s)
1	0.0035	0.0099
2	0.0165	0.168
3	0.1091	0.456
4	0.04	1.36