

## 阅读申明

- 1.本站收集的数据手册和产品资料都来自互联网，版权归原作者所有。如读者和版权方有任何异议请及时告之，我们将妥善解决。
- 2.本站提供的中文数据手册是英文数据手册的中文翻译，其目的是协助用户阅读，该译文无法自动跟随原稿更新，同时也可能存在翻译上的不当。建议读者以英文原稿为参考以便获得更精准的信息。
- 3.本站提供的产品资料，来自厂商的技术支持或者使用者的心得体会等，其内容可能存在描述上的差异，建议读者做出适当判断。
- 4.如需与我们联系，请发邮件到marketing@iczoom.com，主题请标有“数据手册”字样。

## Read Statement

1. The datasheets and other product information on the site are all from network reference or other public materials, and the copyright belongs to the original author and original published source. If readers and copyright owners have any objections, please contact us and we will deal with it in a timely manner.
2. The Chinese datasheets provided on the website is a Chinese translation of the English datasheets. Its purpose is for reader's learning exchange only and do not involve commercial purposes. The translation cannot be automatically updated with the original manuscript, and there may also be improper translations. Readers are advised to use the English manuscript as a reference for more accurate information.
3. All product information provided on the website refer to solutions from manufacturers' technical support or users the contents may have differences in description, and readers are advised to take the original article as the standard.
4. If you have any questions, please contact us at marketing@iczoom.com and mark the subject with "Datasheets" .

# HTZ160C Series

$I_{F(AV)} = 1.7 \text{ A}$   
 $V_{RRM} = 19200 \text{ V}$

# High Voltage Diode Rectifier Module

# LARONTROL

Electronic Devices

Type Number	Repetitive Peak	Minimum Avalanche Voltage $V_{(BR)R}$
HTZ160C19K	19200	20400
HTZ160C17K	16800	18000
HTZ160C14K	14400	15600
HTZ160C12K	12000	13200

CIRCUIT DIAGRAM

Centre Tap



### CURRENT RATINGS - AIR COOLED

$I_{F(AV)}$	Mean forward current	Half wave resistive load $T_{amb} = 35^{\circ}\text{C}$	1.7	A
$I_F$	Continuous (direct) forward current	$T_{amb} = 35^{\circ}\text{C}$	1.9	A
$R_{th(j-a)}$	Thermal resistance junction to ambient		6.5	$^{\circ}\text{C/W}$

### CURRENT RATINGS - OIL COOLED

$I_{F(AV)}$	Mean forward current	Half wave resistive load $T_{oil} = 60^{\circ}\text{C}$	3.7	A
$I_T$	Continuous (direct) forward current	$T_{oil} = 60^{\circ}\text{C}$	4.4	A
$R_{th(j-o)}$	Thermal resistance junction to oil		2.0	$^{\circ}\text{C/W}$

### SURGE RATINGS

$I^2t$	$I^2t$ for fusing	10 ms half sine $T_{vj} = 150^{\circ}\text{C}$	50	$\text{A}^2\text{sec}$
$I_{FSM}$	Surge (non-repetitive) forward current	$T_{vj} = 150^{\circ}\text{C}$	100	A

### TEMPERATURE AND FREQUENCY RATINGS

$T_{vj}$	Virtual junction temperature	Forward (conducting)	180	$^{\circ}\text{C}$
		Reverse (blocking)	180	$^{\circ}\text{C}$
$T_{stg}$	Storage temperature range		-40 to 100	$^{\circ}\text{C}$
f	Frequency range		20 to 400	Hz

### CHARACTERISTICS $T_{case} = 25^{\circ}\text{C}$ unless otherwise stated

$V_{FM}$	Forward voltage	At 2 Amps peak	max 12.0	V
$I_{RM}$	Peak reverse current	At $V_{RRM}$ ; $T_{case} = 150^{\circ}\text{C}$	max 0.5	mA

### Dimensioned Outlines

Dimensions shown are maximum in mm

Weight typ.: 0,26 Kg

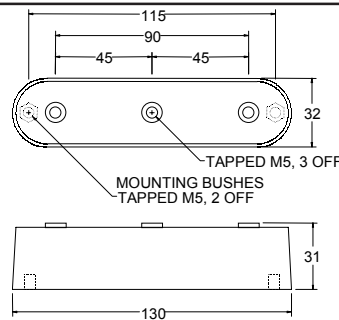

ZC

Issue 1 June 1998

IXYS reserves the right to change limits, test conditions and dimensions.

Distributed by  
 USA  
 3540 Bassett Street  
 Santa Clara, CA 95054  
 Phone: (408) 982-0700  
 FAX: (408) 496-0670

EUROPE  
 IXYS Semiconductor GmbH  
 Lampertheim Germany  
 Phone: +49.6206.503.0  
 Fax: +49.6206.503.627

**IXYS**  
[www.IXYS.net](http://www.IXYS.net)

# HTZ160C Series

$I_{F(AV)} = 1.7 \text{ A}$

$V_{RRM} = 19200 \text{ V}$

# High Voltage Diode Rectifier Module

# LARONTROL

Electronic Devices

