

阅读申明

- 1.本站收集的数据手册和产品资料都来自互联网，版权归原作者所有。如读者和版权方有任何异议请及时告之，我们将妥善解决。
- 2.本站提供的中文数据手册是英文数据手册的中文翻译，其目的是协助用户阅读，该译文无法自动跟随原稿更新，同时也可能存在翻译上的不当。建议读者以英文原稿为参考以便获得更精准的信息。
- 3.本站提供的产品资料，来自厂商的技术支持或者使用者的心得体会等，其内容可能存在描述上的差异，建议读者做出适当判断。
- 4.如需与我们联系，请发邮件到marketing@iczoom.com，主题请标有“数据手册”字样。

Read Statement

1. The datasheets and other product information on the site are all from network reference or other public materials, and the copyright belongs to the original author and original published source. If readers and copyright owners have any objections, please contact us and we will deal with it in a timely manner.
2. The Chinese datasheets provided on the website is a Chinese translation of the English datasheets. Its purpose is for reader's learning exchange only and do not involve commercial purposes. The translation cannot be automatically updated with the original manuscript, and there may also be improper translations. Readers are advised to use the English manuscript as a reference for more accurate information.
3. All product information provided on the website refer to solutions from manufacturers' technical support or users the contents may have differences in description, and readers are advised to take the original article as the standard.
4. If you have any questions, please contact us at marketing@iczoom.com and mark the subject with "Datasheets" .

AC Controller with Isolated Water Flow

$I_{RMS} = 900\text{ A}$
 $V_{RRM} = 1200\text{-}1800\text{ V}$

Preliminary data

V_{RSM} V_{DSM} V	V_{RRM} V_{DRM} V	Type
1300	1200	HVL 900 - 12io1
1500	1400	HVL 900 - 14io1
1700	1600	HVL 900 - 16io1
1900	1800	HVL 900 - 18io1

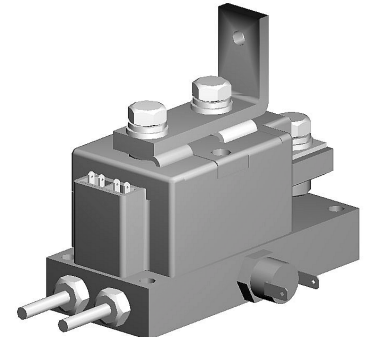
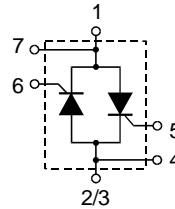

Symbol	Test Conditions	Maximum Ratings	
I_{RMS}	$T_{Water} = 17^{\circ}\text{C}$; watervolume = 4 l/min	900	A
I_{TSM} , I_{FSM}	$T_{VJ} = 45^{\circ}\text{C}$; $V_R = 0$	t = 10 ms (50 Hz) t = 8.3 ms (60 Hz)	9200 A 10100 A
	$T_{VJ} = T_{VJM}$ $V_R = 0$	t = 10 ms (50 Hz) t = 8.3 ms (60 Hz)	8000 A 8800 A
I^2t	$T_{VJ} = 45^{\circ}\text{C}$ $V_R = 0$	t = 10 ms (50 Hz) t = 8.3 ms (60 Hz)	423 000 A ² s 423 000 A ² s
	$T_{VJ} = T_{VJM}$ $V_R = 0$	t = 10 ms (50 Hz) t = 8.3 ms (60 Hz)	320 000 A ² s 321 000 A ² s
$(di/dt)_{cr}$	$T_{VJ} = T_{VJM}$ repetitive, $I_T = 960\text{ A}$ f = 50 Hz, $t_p = 200\ \mu\text{s}$ $V_D = 2/3 V_{DRM}$ $I_G = 1\text{ A}$, $di_G/dt = 1\text{ A}/\mu\text{s}$		100 A/ μs
$(dv/dt)_{cr}$	$T_{VJ} = T_{VJM}$; $V_{DR} = 2/3 V_{DRM}$ $R_{GK} = \infty$; method 1 (linear voltage rise)		1000 V/ μs
P_{GM}	$T_{VJ} = T_{VJM}$	$t_p = 30\ \mu\text{s}$	120 W
	$I_T = I_{TAVM}$	$t_p = 500\ \mu\text{s}$	60 W
P_{GAV}			20 W
V_{RGM}			10 V
T_{VJ}			-40...+140 $^{\circ}\text{C}$
T_{VJM}			140 $^{\circ}\text{C}$
T_{stg}			-40...+125 $^{\circ}\text{C}$
V_{ISOL}	50/60 Hz, RMS t = 1 min		3000 V~
	$I_{ISOL} \leq 1\text{ mA}$ t = 1 s		3600 V~
Weight	Typical including screws		1300 g

Features

- Isolation between water and electrical connections with Direct copper bonded Al_2O_3 -ceramic
- Planar passivated chips
- Isolation voltage 3600 V~
- Keyed gate/cathode twin pins

Applications

- Large resistance welding equipment
- Large electroplating equipment

Data according to IEC 60747 refer to a single thyristor unless otherwise stated.
IXYS reserves the right to change limits, test conditions and dimensions

Symbol	Test Conditions	Characteristic Values
I_{RRM}, I_{DRM}	$T_{VJ} = T_{VJM}; V_R = V_{RRM}; V_D = V_{DRM}$	40 mA
V_T, V_F	$I_T, I_F = 600 \text{ A}; T_{VJ} = 25^\circ\text{C}$	1.32 V
V_{T0}	For power-loss calculations only	0.8 V
r_T		0.68 mΩ
V_{GT}	$V_D = 6 \text{ V}; T_{VJ} = 25^\circ\text{C}$	2 V
	$T_{VJ} = -40^\circ\text{C}$	3 V
I_{GT}	$V_D = 6 \text{ V}; T_{VJ} = 25^\circ\text{C}$	150 mA
	$T_{VJ} = -40^\circ\text{C}$	220 mA
V_{GD}	$T_{VJ} = T_{VJM}; V_D = 2/3 V_{DRM}$	0.25 V
I_{GD}	$T_{VJ} = T_{VJM}; V_D = 2/3 V_{DRM}$	10 mA
I_L	$T_{VJ} = 25^\circ\text{C}; t_p = 30 \mu\text{s}; V_D = 6 \text{ V}$ $I_G = 0.45 \text{ A}; di_G/dt = 0.45 \text{ A}/\mu\text{s}$	200 mA
I_H	$T_{VJ} = 25^\circ\text{C}; V_D = 6 \text{ V}; R_{GK} = \infty$	150 mA
t_{gd}	$T_{VJ} = 25^\circ\text{C}; V_D = 1/2 V_{DRM}$ $I_G = 1 \text{ A}; di_G/dt = 1 \text{ A}/\mu\text{s}$	2 μs
Q_S	$T_{VJ} = 125^\circ\text{C}; I_T, I_F = 300 \text{ A}; -di/dt = 50 \text{ A}/\mu\text{s}$	760 μC
I_{RM}		275 A
R_{thJW}	per thyristor ; 180° el; watervolume = 4 l/min	0.203 K/W
d_S	Creeping distance on surface	12.7 mm
d_A	Creepage distance in air	
a	Maximum allowable acceleration	

Optional accessories for modules

Keyed Gate/Cathode twin plugs with wire length = 350 mm, gate = yellow, cathode = red
 Type **ZY 180 L** (L = Left for pin pair 4/5) } UL 758, style 1385,
 Type **ZY 180 R** (R = Right for pin pair 6/7) } CSA class 5851, guide 460-1-1

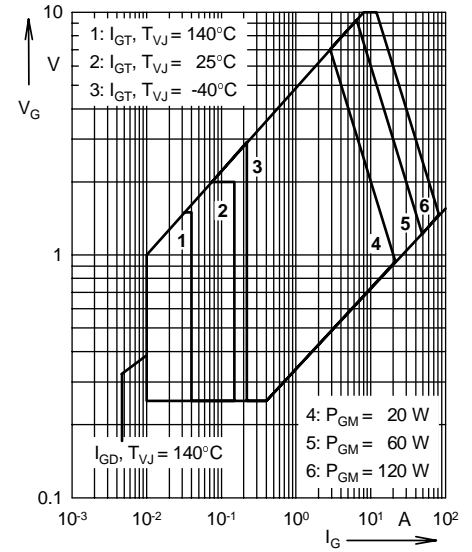
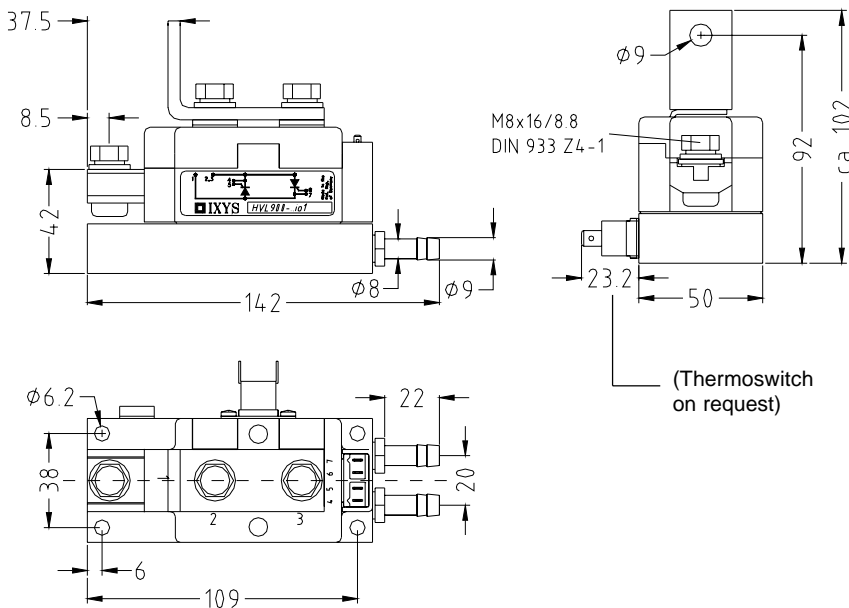

Fig. 1 Gate trigger characteristics

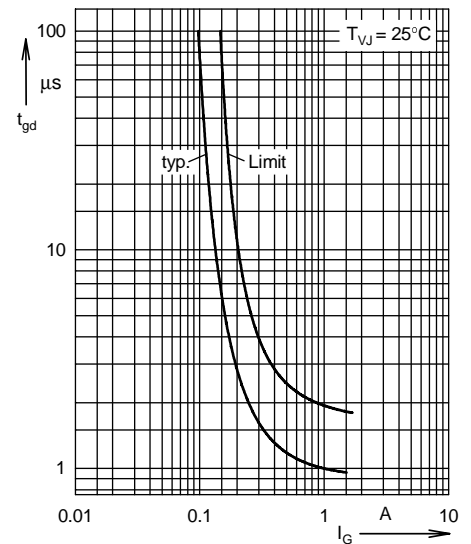

Fig. 2 Gate trigger delay time

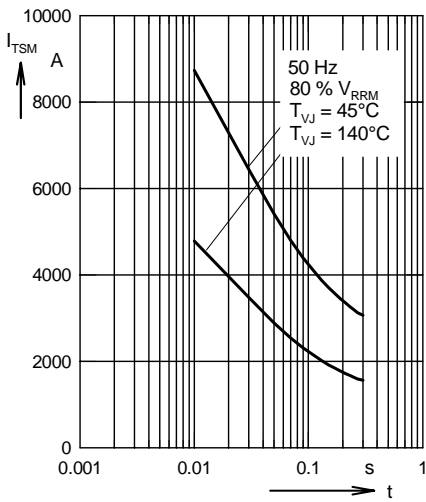

Fig. 3 Surge overload current
 I_{TSM} : Crest value, t : duration

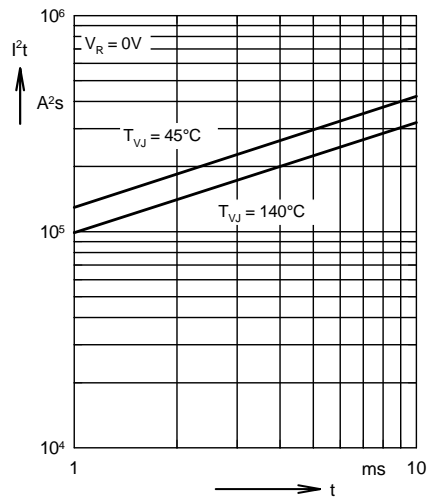

Fig. 4 I^2t versus time (1-10 ms)

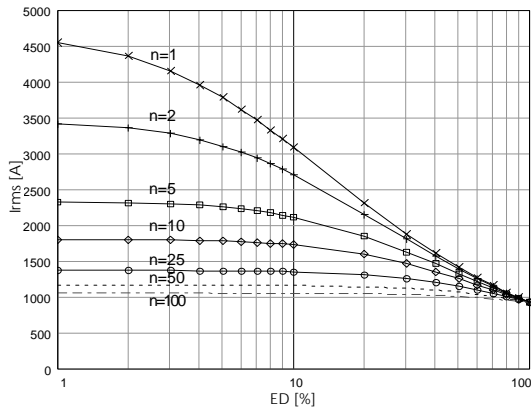

Fig. 5 Rated rms current vs. duty cycle

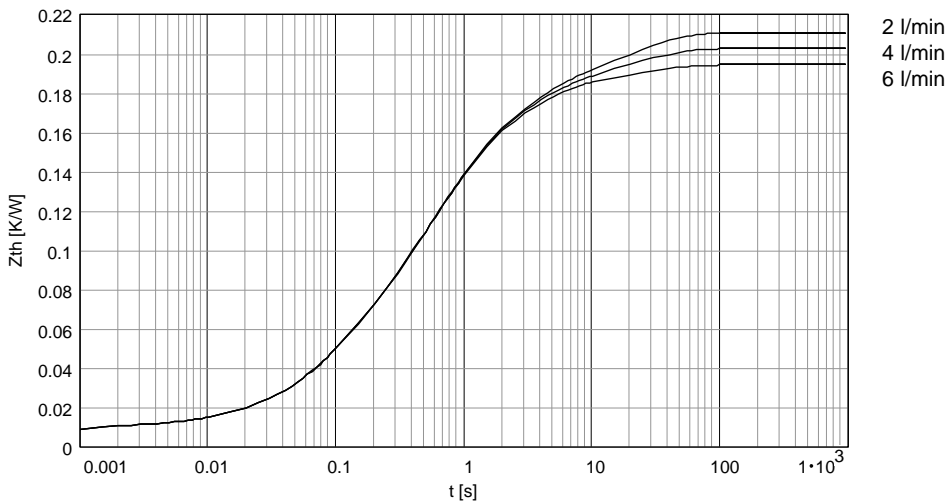

Fig. 6 Transient thermal impedance vs. time