

## 阅读申明

- 1.本站收集的数据手册和产品资料都来自互联网，版权归原作者所有。如读者和版权方有任何异议请及时告之，我们将妥善解决。
- 2.本站提供的中文数据手册是英文数据手册的中文翻译，其目的是协助用户阅读，该译文无法自动跟随原稿更新，同时也可能存在翻译上的不当。建议读者以英文原稿为参考以便获得更精准的信息。
- 3.本站提供的产品资料，来自厂商的技术支持或者使用者的心得体会等，其内容可能存在描述上的差异，建议读者做出适当判断。
- 4.如需与我们联系，请发邮件到marketing@iczoom.com，主题请标有“数据手册”字样。

## Read Statement

1. The datasheets and other product information on the site are all from network reference or other public materials, and the copyright belongs to the original author and original published source. If readers and copyright owners have any objections, please contact us and we will deal with it in a timely manner.
2. The Chinese datasheets provided on the website is a Chinese translation of the English datasheets. Its purpose is for reader's learning exchange only and do not involve commercial purposes. The translation cannot be automatically updated with the original manuscript, and there may also be improper translations. Readers are advised to use the English manuscript as a reference for more accurate information.
3. All product information provided on the website refer to solutions from manufacturers' technical support or users the contents may have differences in description, and readers are advised to take the original article as the standard.
4. If you have any questions, please contact us at marketing@iczoom.com and mark the subject with "Datasheets" .

TOSHIBA Transistor Silicon PNP Epitaxial Type (PCT Process)

## RN2601, RN2602, RN2603 RN2604, RN2605, RN2606

Switching, Inverter Circuit, Interface Circuit  
And Driver Circuit Applications

- Including two devices in SM6 (super mini type with 6 leads)
- With built-in bias resistors
- Simplify circuit design
- Reduce a quantity of parts and manufacturing process
- Complementary to RN1601~1606

### Equivalent Circuit and Bias Resistor Values

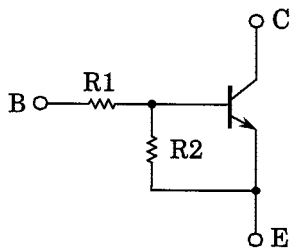

Type No.	R1 (kΩ)	R2 (kΩ)
RN2601	4.7	4.7
RN2602	10	10
RN2603	22	22
RN2604	47	47
RN2605	2.2	47
RN2606	4.7	47

Unit in mm

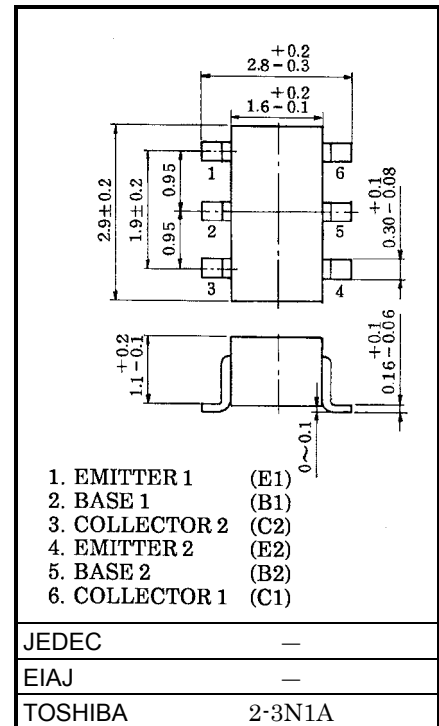

Weight: 0.015g

### Equivalent Circuit (Top View)

### Maximum Ratings (Ta = 25°C) (Q1, Q2 Common)

Characteristic	Symbol	Rating	Unit
Collector-base voltage	$V_{CB0}$	-50	V
Collector-emitter voltage	$V_{CEO}$	-50	V
Emitter-base voltage	$V_{EBO}$	-10	V
		-5	
Collector current	$I_C$	-100	mA
Collector power dissipation	$P_C^*$	300	mW
Junction temperature	$T_j$	150	°C
Storage temperature range	$T_{stg}$	-55~150	°C

\* Total rating

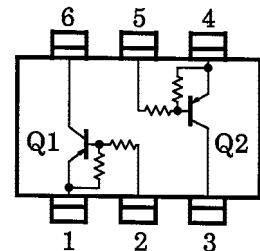

## Electrical Characteristics (Ta = 25°C) (Q1, Q2 common)

Characteristic		Symbol	Test Circuit	Test Condition	Min	Typ.	Max	Unit
Collector cut-off current	RN2601~2606	$I_{CBO}$	—	$V_{CB} = -50V, I_E = 0$	—	—	-100	nA
		$I_{CEO}$	—	$V_{CE} = -50V, I_B = 0$	—	—	-500	
Emitter cut-off current	RN2601	$I_{EBO}$	—	$V_{EB} = -10V, I_C = 0$	-0.82	—	-1.52	mA
	RN2602		—		-0.38	—	-0.71	
	RN2603		—		-0.17	—	-0.33	
	RN2604		—	-0.082	—	-0.15		
	RN2605		—	$V_{EB} = -5V, I_C = 0$	-0.078	—	-0.145	
	RN2606		—		-0.074	—	-0.138	
DC current gain	RN2601	$h_{FE}$	—	$V_{CE} = -5V$ $I_C = -10mA$	30	—	—	—
	RN2602		—		50	—	—	
	RN2603		—		70	—	—	
	RN2604		—		80	—	—	
	RN2605		—		80	—	—	
	RN2606		—		80	—	—	
Collector-emitter saturation voltage	RN2601~2606	$V_{CE(sat)}$	—	$I_C = -5mA$ $I_B = -0.25mA$	—	-0.1	-0.3	V
Input voltage (ON)	RN2601	$V_{I(ON)}$	—	$V_{CE} = -0.2V$ $I_C = -5mA$	-1.1	—	-2.0	V
	RN2602		—		-1.2	—	-2.4	
	RN2603		—		-1.3	—	-3.0	
	RN2604		—		-1.5	—	-5.0	
	RN2605		—		-0.6	—	-1.1	
	RN2606		—		-0.7	—	-1.3	
Input voltage (OFF)	RN2601~2604	$V_{I(OFF)}$	—	$V_{CE} = -5V,$ $I_C = -0.1mA$	-1.0	—	-1.5	V
	RN2605, 2606		—		-0.5	—	-0.8	
Translation frequency	RN2601~2606	$f_T$	—	$V_{CE} = -10V,$ $I_C = -5mA$	—	200	—	MHz
Collector output capacitance	RN2601~2606	$C_{ob}$	—	$V_{CB} = -10V, I_E = 0$ $f = 1MHz$	—	3	6	pF
Input resistor	RN2601	R1	—	—	3.29	4.7	6.11	kΩ
	RN2602		—		7	10	13	
	RN2603		—		15.4	22	28.6	
	RN2604		—		32.9	47	61.1	
	RN2605		—		1.54	2.2	2.86	
	RN2606		—		3.29	4.7	6.11	
Resistor ratio	RN2601~2604	R1/R2	—	—	0.9	1.0	1.1	—
	RN2605		—		0.0421	0.0468	0.0515	
	RN2606		—		0.09	0.1	0.11	

(Q1, Q2 Common)

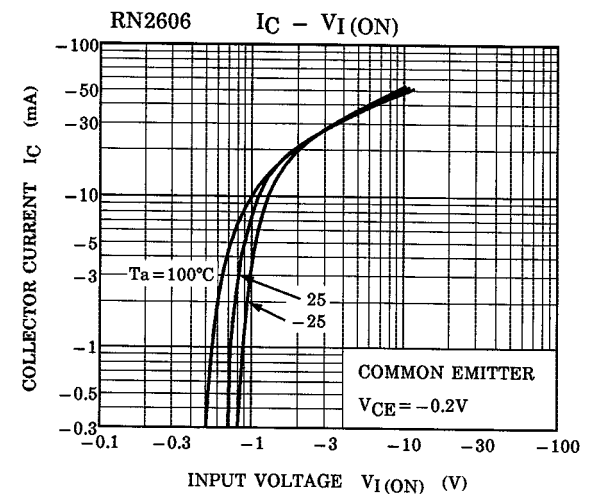
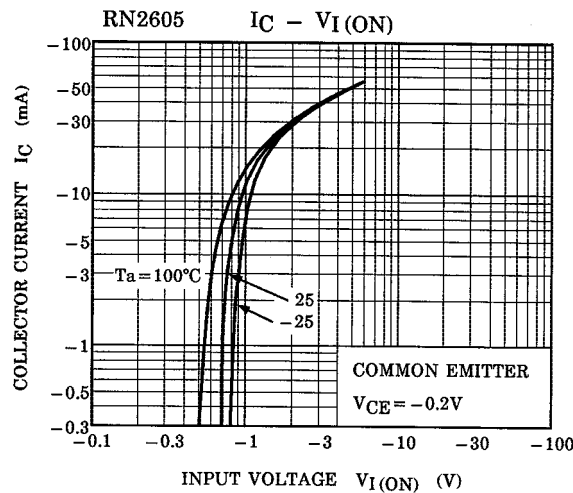
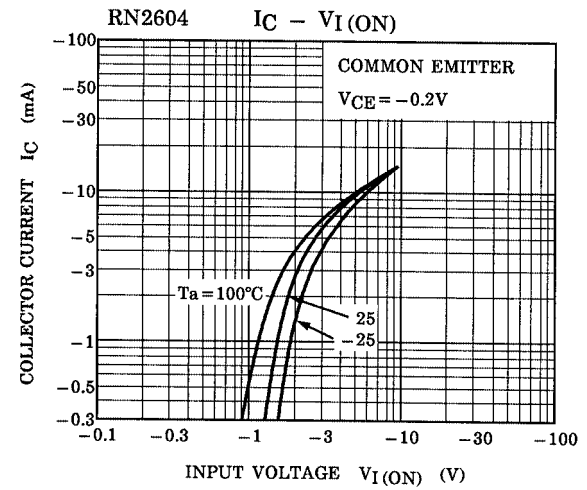
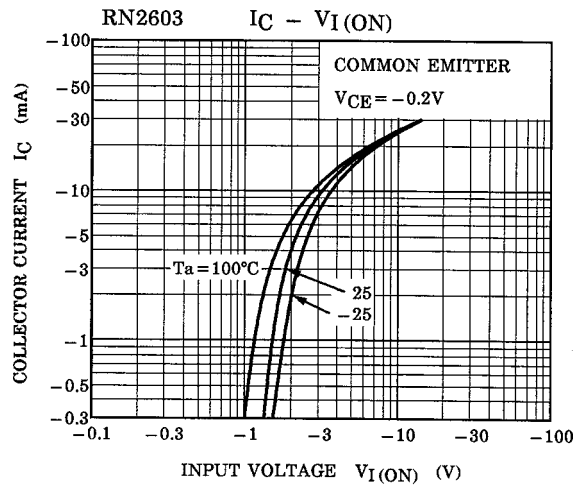
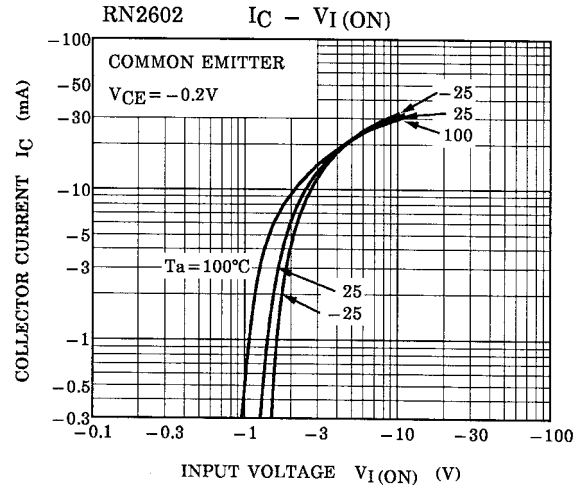
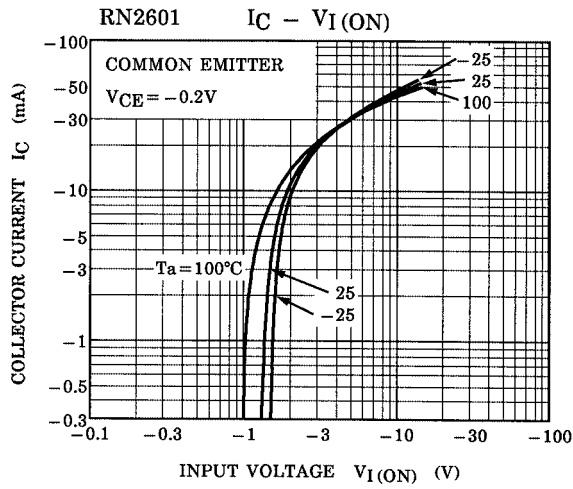

(Q1, Q2 Common)

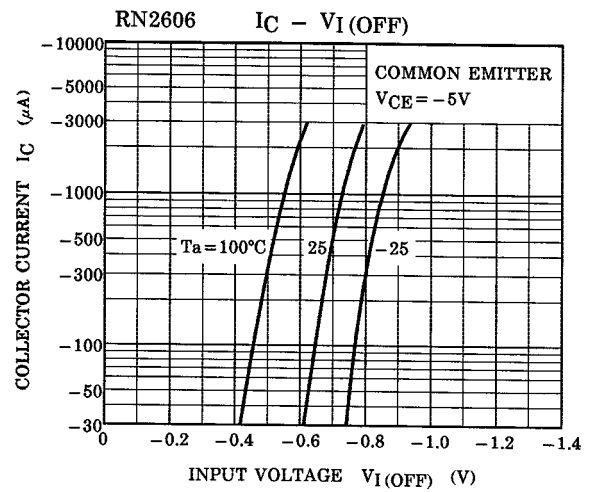
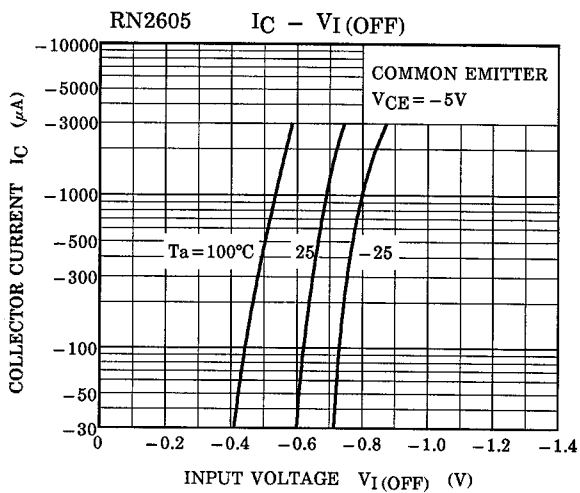
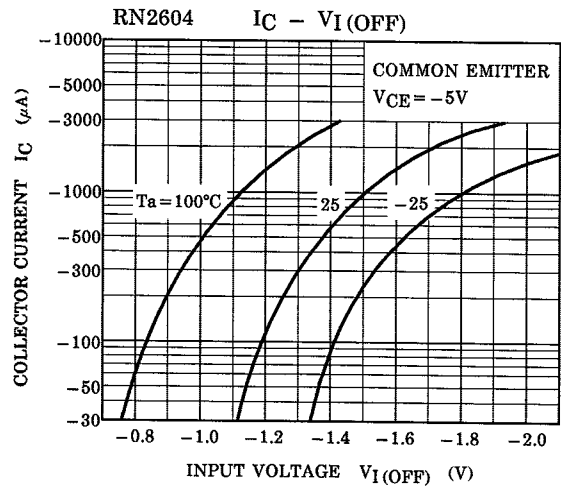
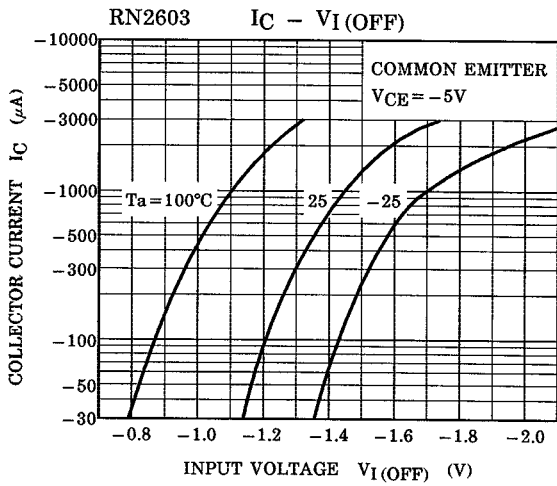
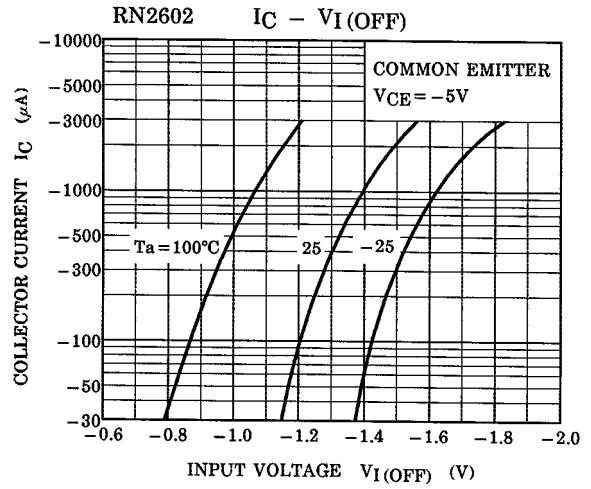
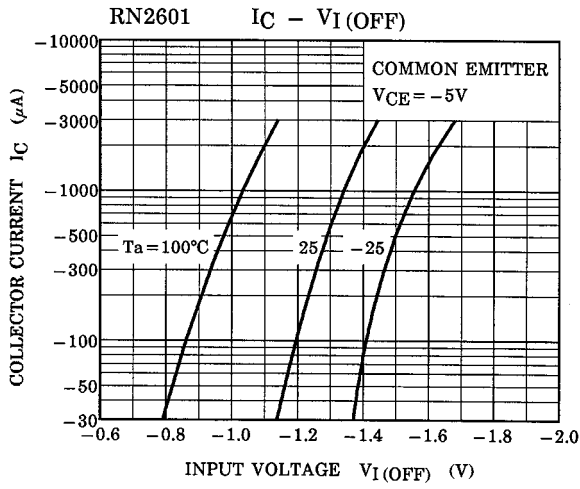

(Q1, Q2 Common)

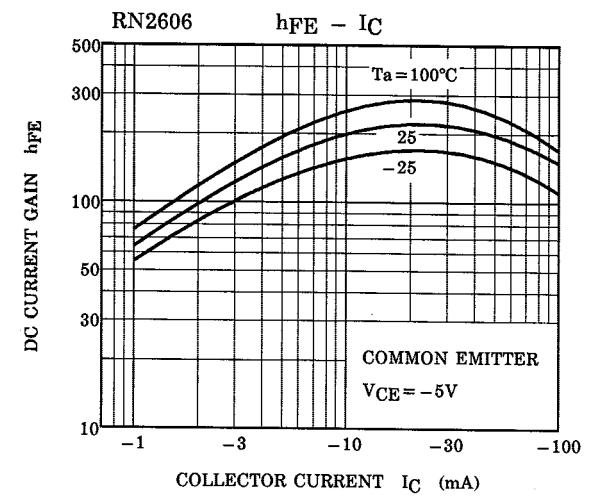
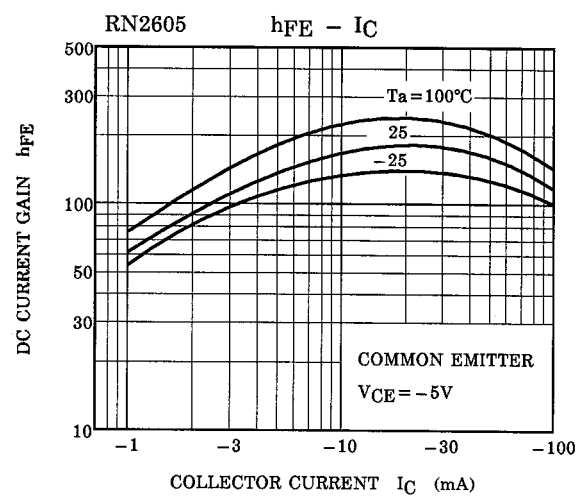
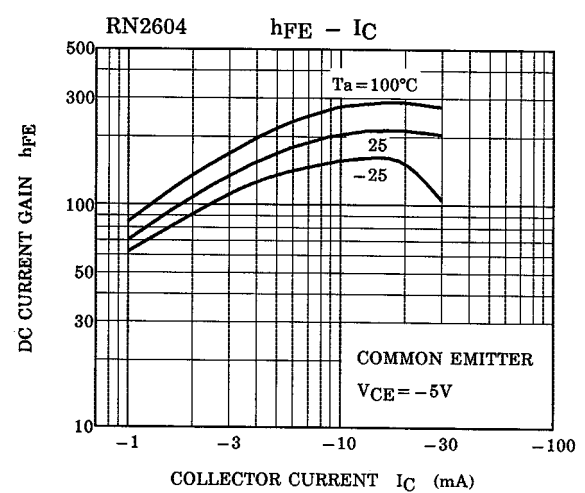
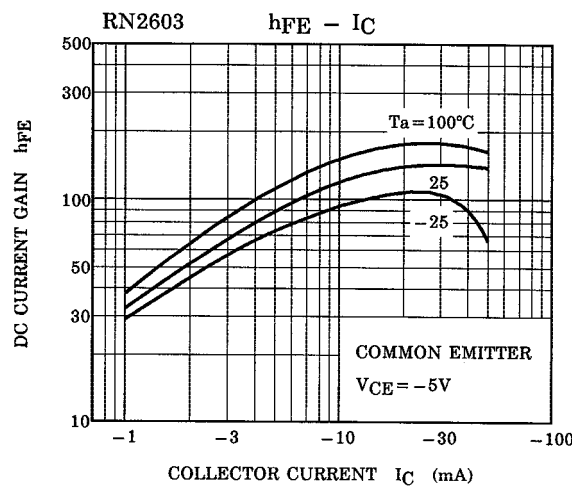
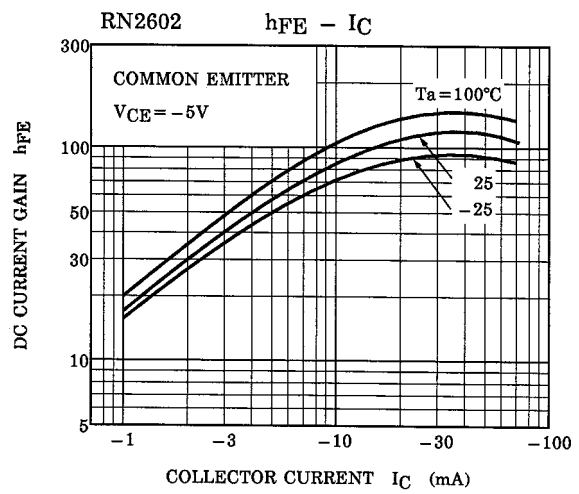
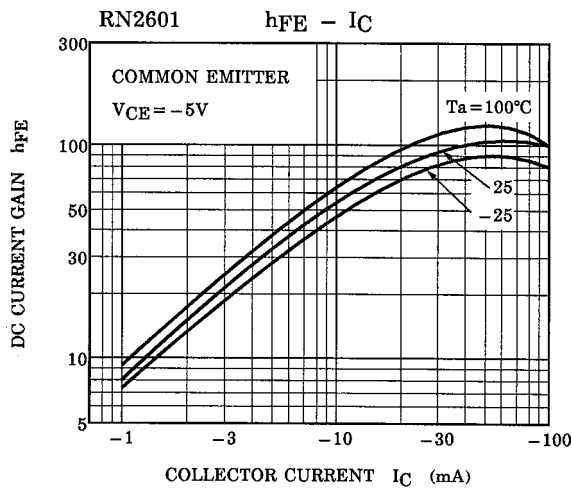

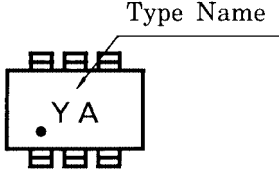
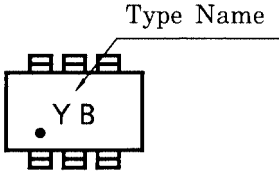
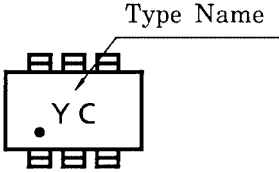
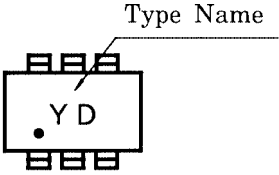
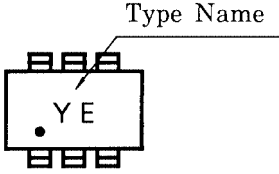
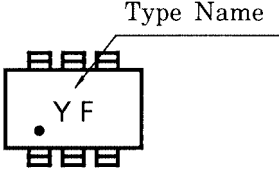
Type Name	Marking
RN2601	 <p>The diagram shows a rectangular component with four pins on each of the top and bottom edges. The marking 'YA' is printed in the center, with a small dot to its left. A line points from the text 'Type Name' to the top edge of the component.</p>
RN2602	 <p>The diagram shows a rectangular component with four pins on each of the top and bottom edges. The marking 'YB' is printed in the center, with a small dot to its left. A line points from the text 'Type Name' to the top edge of the component.</p>
RN2603	 <p>The diagram shows a rectangular component with four pins on each of the top and bottom edges. The marking 'YC' is printed in the center, with a small dot to its left. A line points from the text 'Type Name' to the top edge of the component.</p>
RN2604	 <p>The diagram shows a rectangular component with four pins on each of the top and bottom edges. The marking 'YD' is printed in the center, with a small dot to its left. A line points from the text 'Type Name' to the top edge of the component.</p>
RN2605	 <p>The diagram shows a rectangular component with four pins on each of the top and bottom edges. The marking 'YE' is printed in the center, with a small dot to its left. A line points from the text 'Type Name' to the top edge of the component.</p>
RN2606	 <p>The diagram shows a rectangular component with four pins on each of the top and bottom edges. The marking 'YF' is printed in the center, with a small dot to its left. A line points from the text 'Type Name' to the top edge of the component.</p>

**RESTRICTIONS ON PRODUCT USE**

000707EAA

- TOSHIBA is continually working to improve the quality and reliability of its products. Nevertheless, semiconductor devices in general can malfunction or fail due to their inherent electrical sensitivity and vulnerability to physical stress. It is the responsibility of the buyer, when utilizing TOSHIBA products, to comply with the standards of safety in making a safe design for the entire system, and to avoid situations in which a malfunction or failure of such TOSHIBA products could cause loss of human life, bodily injury or damage to property.  
In developing your designs, please ensure that TOSHIBA products are used within specified operating ranges as set forth in the most recent TOSHIBA products specifications. Also, please keep in mind the precautions and conditions set forth in the "Handling Guide for Semiconductor Devices," or "TOSHIBA Semiconductor Reliability Handbook" etc..
- The TOSHIBA products listed in this document are intended for usage in general electronics applications (computer, personal equipment, office equipment, measuring equipment, industrial robotics, domestic appliances, etc.). These TOSHIBA products are neither intended nor warranted for usage in equipment that requires extraordinarily high quality and/or reliability or a malfunction or failure of which may cause loss of human life or bodily injury ("Unintended Usage"). Unintended Usage include atomic energy control instruments, airplane or spaceship instruments, transportation instruments, traffic signal instruments, combustion control instruments, medical instruments, all types of safety devices, etc.. Unintended Usage of TOSHIBA products listed in this document shall be made at the customer's own risk.
- The information contained herein is presented only as a guide for the applications of our products. No responsibility is assumed by TOSHIBA CORPORATION for any infringements of intellectual property or other rights of the third parties which may result from its use. No license is granted by implication or otherwise under any intellectual property or other rights of TOSHIBA CORPORATION or others.
- The information contained herein is subject to change without notice.