

阅读申明

- 1.本站收集的数据手册和产品资料都来自互联网，版权归原作者所有。如读者和版权方有任何异议请及时告之，我们将妥善解决。
- 2.本站提供的中文数据手册是英文数据手册的中文翻译，其目的是协助用户阅读，该译文无法自动跟随原稿更新，同时也可能存在翻译上的不当。建议读者以英文原稿为参考以便获得更精准的信息。
- 3.本站提供的产品资料，来自厂商的技术支持或者使用者的心得体会等，其内容可能存在描述上的差异，建议读者做出适当判断。
- 4.如需与我们联系，请发邮件到marketing@iczoom.com，主题请标有“数据手册”字样。

Read Statement

1. The datasheets and other product information on the site are all from network reference or other public materials, and the copyright belongs to the original author and original published source. If readers and copyright owners have any objections, please contact us and we will deal with it in a timely manner.
2. The Chinese datasheets provided on the website is a Chinese translation of the English datasheets. Its purpose is for reader's learning exchange only and do not involve commercial purposes. The translation cannot be automatically updated with the original manuscript, and there may also be improper translations. Readers are advised to use the English manuscript as a reference for more accurate information.
3. All product information provided on the website refer to solutions from manufacturers' technical support or users the contents may have differences in description, and readers are advised to take the original article as the standard.
4. If you have any questions, please contact us at marketing@iczoom.com and mark the subject with "Datasheets" .

AA-100 / AA-150 / AA-200 Outdoor Thermoelectric Cooler Assemblies

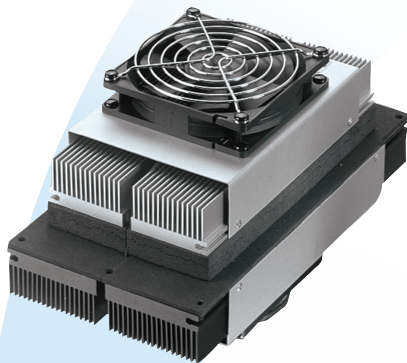

THERMOELECTRIC COOLING UNITS FOR OUTDOOR ENCLOSURES AND KIOSKS

Laird Technologies is the leading manufacturer of thermoelectric cooling assemblies with hundreds of thousands of units supplied in the field. Our broad range of outdoor cooling units have passed rigorous Telcordia test requirements conducted by our customers, such as earthquake resistance, salt fog, wind-driven rain, high temperature exposure, dust, etc.

These outdoor units have the reputation for high reliability due to the selection of world class components such as major brand fans with the highest degree of environmental protection and lifetime guaranteed waterproof connectors, heavy duty anodization on the high-density heat sinks, overheat protection, and double environmental seals for the TE modules. TE Coolers are also known as Peltier and Solid State coolers.

FEATURES AND BENEFITS

- 100W, 150W, 200W capacities rated at $\Delta T_{amb} = 0^{\circ}\text{C}$, $T_{ext} = 32^{\circ}\text{C}$
- DC power options available for +24VDC and -48VDC
- Wide operating temperature range of -40°C to $+55^{\circ}\text{C}$
- Telcordia GR-487-CORE tested and verified by customers when integrated in telecom outdoor enclosures
- Gaskets, connectors, and fans provide a NEMA 4 seal for the enclosure
- UL60950 and UL50 approval obtained by customers when integrated in telecom outdoor enclosures
- Environmentally friendly solid state operation – no compressor or CFC refrigerants
- Cooling and heating in the same unit; optional temperature controller reverses the polarity of current to generate heating
- Optional equipment: sheet metal shrouds, power supplies, and spares

APPLICATIONS

- Outdoor telecom enclosures
- Outdoor kiosks and displays
- Harsh condition electronic cabinets
- Battery cabinets

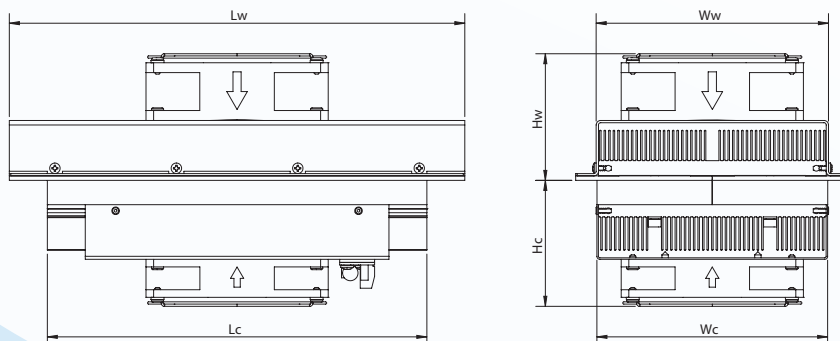

global solutions: local support.™

Americas: +1.888.246.9050

Europe: +46.31.704.67.57

Asia: +86.755.2714.1166

CLV-customerservice@lairdtech.com

www.lairdtech.com/thermal

AA-100 / AA-150 / AA-200 Outdoor Thermoelectric Cooler Assemblies

SPECIFICATIONS	AA-100-...	AA-150-...	AA-200-...
Technical			
Technology	Thermoelectric (TE) modules, forced air, closed loop (non-mixing), filterless, non-refrigerant		
Cooling at $dT = 0^{\circ}\text{C}$, and nominal / float voltage. ¹	102/113W (348/386 Btu/h)	143/159W (488/543 Btu/h)	193/214W (659/731 Btu/h)
Heating ²	125W (427 Btu/h)	150W (512 Btu/h)	250W (853 Btu/h)
Voltage (nominal / maximum)	24/28 VDC 48/56 VDC	24/28 VDC 48/56 VDC	24/28 VDC 48/56 VDC
Grounding (all voltages)	Positive or negative		
Current draw, $\pm 10\%$ (nominal / startup)	5.6/7.2 A (24V version) 2.8/3.6 A (48V version)	7.9/10.0 A (24V version) 3.9/5.0 A (48V version)	11.3/14.3 A (24V version) 5.6/7.2 A (48V version)
Dimensions, cold side ($L_c \times W_c \times H_c$)	230 x 122 x 83 mm (9.1 x 4.8 x 3.3 in)	250 x 152 x 83 mm (9.8 x 6.0 x 3.3 in)	350 x 152 x 89 mm (13.8 x 6.0 x 3.5 in)
Dimensions, warm side ($L_w \times W_w \times H_w$)	300 x 152 x 78 mm (11.8 x 6.0 x 3.1 in)	300 x 180 x 84 mm (11.8 x 7.1 x 3.3 in)	400 x 180 x 89 mm (15.7 x 7.1 x 3.5 in)
Weight	4.1 kg (9.0 lbs)	5.1 kg (11.2 lbs)	6.6 kg (14.5 lbs)
Panel mounting	Through		
Fan life (L_{10} at $+40^{\circ}\text{C}$)	$\geq 70,000$ hours		
Number of connectors (with / without controller)	1/3		
Connector type (on unit / mating side)	On unit: AMP part number: 350777-1, 794269, 350547-6, 794270-1 Mating side: AMP part number : 350778-1, 350550-6, 794270-1		
Hi-pot testing	707 VDC		
Environmental			
Temperature range ³ (external ambient)	-40°C to $+55^{\circ}\text{C}$ (-40°F to $+131^{\circ}\text{F}$)		
Temperature range (internal enclosure)	-20°C to $+55^{\circ}\text{C}$ (-4°F to $+131^{\circ}\text{F}$)		
Degree of protection, enclosure ⁴	NEMA 4 (IP55)		
Degree of protection, unit ⁵	IP54		
Sound level (1m distance)	58 dB(A)	58 dB(A)	63 dB(A)
Controllers (optional)			
LK-81 – Thermostatic control (solid state)	Cooling, set point 25°C (77°F), $\pm 2^{\circ}\text{C}$ (3.5°F) Heating, set point 10°C (50°F), $\pm 2^{\circ}\text{C}$ (3.5°F)		
LK-81 – Low Voltage Disconnect / Re-connect (LVD / LVD-R)	25.0 / 26.0V, $\pm 0.5\text{V}$ (24 VDC versions) 50.2 / 51.4V, $\pm 0.5\text{V}$ (48 VDC version A) 47.0 / 49.0V, $\pm 0.5\text{V}$ (48 VDC version B)		
LK-81 – Regulation	ON/OFF		
Ordering codes			
24V, without controller	AA-100-24-44-00-XX	AA-150-24-44-00-XX	AA-200-24-44-00-XX
24V, with controller		AA-150-24-44-LK-XX	AA-200-24-44-LK-XX
48V, without controller	AA-100-48-44-00-XX	AA-150-48-44-00-XX	AA-200-48-44-00-XX
48V, with controller		AA-150-48-44-LK-XX	AA-200-48-44-LK-XX

¹ Cooling capacities at nominal / float voltage are rated at external temperatures of 32°C and 46°C respectively. Float voltage is defined as 27 and 54 VDC.

² Heating capacity is rated at external temperature of -40°C , nominal voltage, and $dT = -45^{\circ}\text{C}$.

³ Controller function shall not operate the external fan during heating mode.

⁴ The highest environmental protection level requires an external shroud and is defined as the protection level for the enclosure.

⁵ Rating for unit without protective shroud.

Note: The specified performance of any Laird Technologies cooling unit is dependent on how it is handled and incorporated into the final product. This includes elements such as the system design, insulation design, and assembly method. While Laird Technologies is able to provide general guidelines based upon our experience, it is ultimately the responsibility of the device manufacturer to validate each product and its performance for its intended use.

THR-DS-TEA 0610

Any information furnished by Laird Technologies, Inc. and its agents is believed to be accurate and reliable. All specifications are subject to change without notice. Responsibility for the use and application of Laird Technologies materials rests with the end user, since Laird Technologies and its agents cannot be aware of all potential uses. Laird Technologies makes no warranties as to the fitness, merchantability or suitability of any Laird Technologies materials or products for any specific or general uses. Laird Technologies shall not be liable for incidental or consequential damages of any kind. All Laird Technologies products are sold pursuant to the Laird Technologies' Terms and Conditions of sale in effect from time to time, a copy of which will be furnished upon request. © Copyright 2010 Laird Technologies, Inc. All Rights Reserved. Laird, Laird Technologies, the Laird Technologies Logo, and other marks are trademarks or registered trademarks of Laird Technologies, Inc. or an affiliate company thereof. Other product or service names may be the property of third parties. Nothing herein provides a license under any Laird Technologies or any third party intellectual property rights.