

## 阅读申明

- 1.本站收集的数据手册和产品资料都来自互联网，版权归原作者所有。如读者和版权方有任何异议请及时告之，我们将妥善解决。
- 2.本站提供的中文数据手册是英文数据手册的中文翻译，其目的是协助用户阅读，该译文无法自动跟随原稿更新，同时也可能存在翻译上的不当。建议读者以英文原稿为参考以便获得更精准的信息。
- 3.本站提供的产品资料，来自厂商的技术支持或者使用者的心得体会等，其内容可能存在描述上的差异，建议读者做出适当判断。
- 4.如需与我们联系，请发邮件到marketing@iczoom.com，主题请标有“数据手册”字样。

## Read Statement

1. The datasheets and other product information on the site are all from network reference or other public materials, and the copyright belongs to the original author and original published source. If readers and copyright owners have any objections, please contact us and we will deal with it in a timely manner.
2. The Chinese datasheets provided on the website is a Chinese translation of the English datasheets. Its purpose is for reader's learning exchange only and do not involve commercial purposes. The translation cannot be automatically updated with the original manuscript, and there may also be improper translations. Readers are advised to use the English manuscript as a reference for more accurate information.
3. All product information provided on the website refer to solutions from manufacturers' technical support or users the contents may have differences in description, and readers are advised to take the original article as the standard.
4. If you have any questions, please contact us at marketing@iczoom.com and mark the subject with "Datasheets" .



# Common Beads

## For Audio / USB1.1 Signal Lines

Conformity to RoHS Directive

### MCZ Series MCZ1210-D(2-Line)

This is a common type bead product that removes the noise components in a signal line and includes beads for two lines in a single chip. The product exhibits substantial impedance characteristics in the high frequency range and is therefore capable of effectively removing differential mode noises. Additionally, an appropriate amount of magnetic coupling is created between the beads of the two lines, giving the product the capability to remove not only differential mode noise but common mode noise as well. It is encased in a 1210 casing. This is an SMD product that allows for automatic mounting by taping.

#### FEATURES

- Compact size, Low Rdc (0.75Ω max.)
- Capable of removing both common and differential mode noises.
- Closed magnetic circuit structure allows high-density installation while preventing crosstalk between circuits.

#### APPLICATIONS

Removal of audio signal line noises of cellular phones, PCs, note PCs, DSCs, portable game machines, etc.

#### PRODUCT IDENTIFICATION

MCZ	1210	AD	102	T	□□□
(1)	(2)	(3)	(4)	(5)	(6)

- (1) Series name
- (2) Dimensions L×W
- (3) Type name
- (4) Open mode impedance  
102:1000Ω at 100MHz
- (5) Packaging style  
T:Taping
- (6) TDK internal code

#### SHAPES AND DIMENSIONS/RECOMMENDED PC BOARD PATTERN

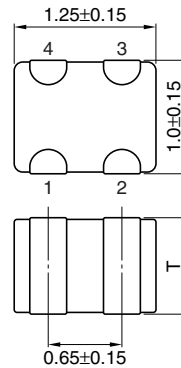

T	Weight
0.5±0.10mm	3mg
0.85±0.15mm	4mg

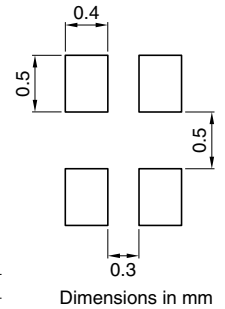

#### CIRCUIT DIAGRAM

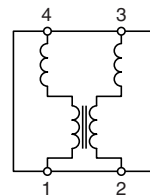

- No polarity



#### TEMPERATURE RANGES

Operating/Storage	-40 to +85°C
-------------------	--------------

#### PACKAGING STYLE AND QUANTITIES

Packaging style	Quantity
Taping	4000 pieces/reel

#### HANDLING AND PRECAUTIONS

- Before soldering, be sure to preheat components. The preheating temperature should be set so that the temperature difference between the solder temperature and product temperature does not exceed 150°C.
- After mounting components onto the printed circuit board, do not apply stress through board bending or mishandling.
- Do not expose the inductors to stray magnetic fields.
- Avoid static electricity discharge during handling.
- When hand soldering, apply the soldering iron to the printed circuit board only. Temperature of the iron tip should not exceed 350°C. Soldering time should not exceed 3 seconds.
- This product does not apply to flow soldering construction method.

- Conformity to RoHS Directive: This means that, in conformity with EU Directive 2002/95/EC, lead, cadmium, mercury, hexavalent chromium, and specific bromine-based flame retardants, PBB and PBDE, have not been used, except for exempted applications.
- Please contact our Sales office when your application is considered the following:  
The device's failure or malfunction may directly endanger human life (e.g. application for automobile/aircraft/medical/nuclear power devices, etc.)

• All specifications are subject to change without notice.

## ELECTRICAL CHARACTERISTICS

Part No.	Open mode impedance ( $\Omega$ )[at 100MHz]*	DC resistance ( $\Omega$ )max.	Insulation resistance ( $M\Omega$ )min.	Rated voltage Edc(V)max.	Rated current Idc(mA)max.	Thickness T (mm)
MCZ1210AD102T	1000 $\pm$ 25%	0.75	1	5	50	0.85
MCZ1210AD221T	220 $\pm$ 25%	0.3	1	5	350	0.85
MCZ1210AD121T002	120 $\pm$ 25%	0.2	1	5	500	0.5
MCZ1210AD900T002	90 $\pm$ 25%	0.2	1	5	500	0.5

\* Test equipment: E4991A or equivalent

Test tool: 16192A or equivalent

Test temperature: 25 $\pm$ 10°C

## TYPICAL ELECTRICAL CHARACTERISTICS

### IMPEDANCE vs. FREQUENCY CHARACTERISTICS

#### MCZ1210AD102

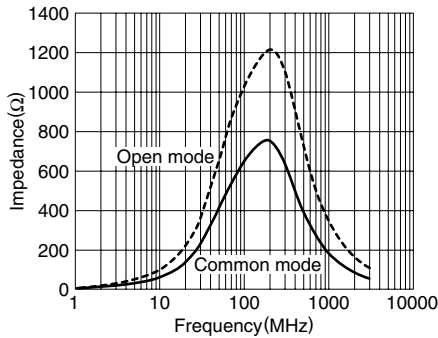

#### MCZ1210AD221

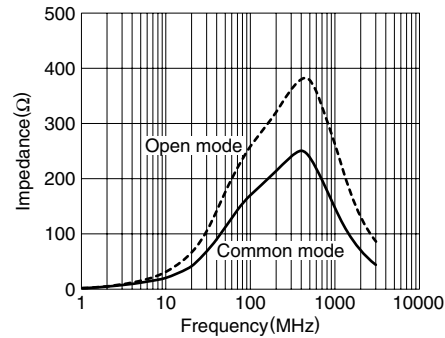

#### MCZ1210AD121T002

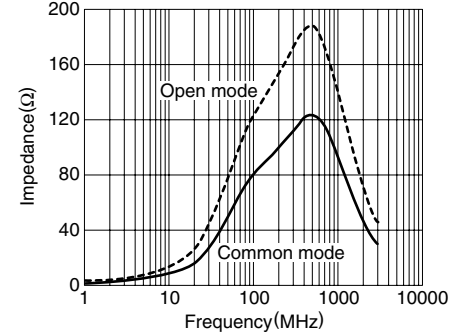

#### MCZ1210AD900T002

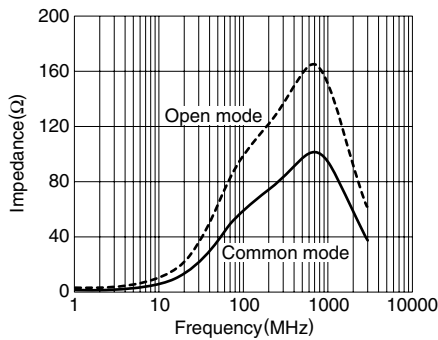

## MEASURING CIRCUITS

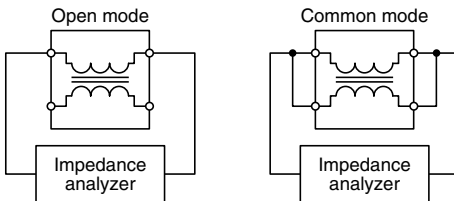

## PACKAGING STYLES

### REEL DIMENSIONS

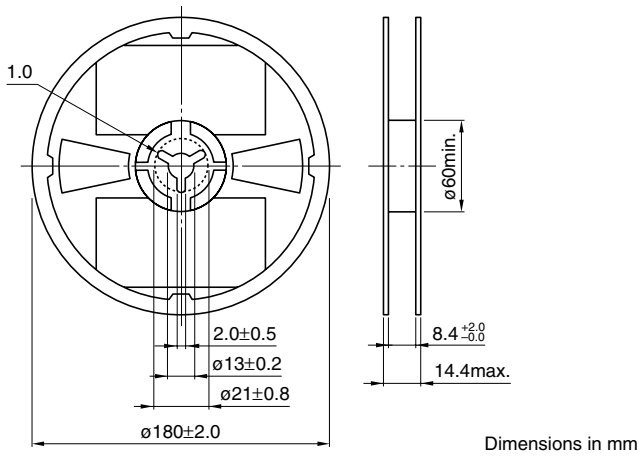

### TAPE DIMENSIONS

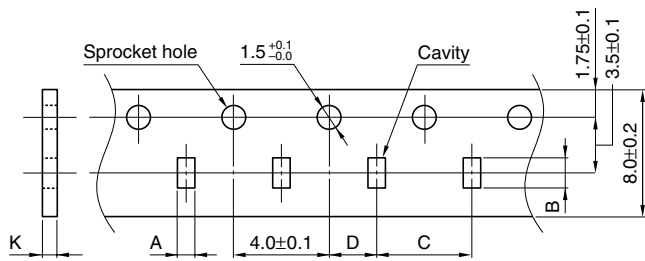

Thickness	A	B	C	D	K
0.85mm	$1.2 \pm 0.1$	$1.45 \pm 0.1$	$4.0 \pm 0.1$	$2.0 \pm 0.1$	$0.95 \pm 0.10$
0.50mm	$1.2 \pm 0.1$	$1.45 \pm 0.1$	$4.0 \pm 0.1$	$2.0 \pm 0.1$	$0.60 \pm 0.05$

