

阅读申明

- 1.本站收集的数据手册和产品资料都来自互联网，版权归原作者所有。如读者和版权方有任何异议请及时告之，我们将妥善解决。
- 2.本站提供的中文数据手册是英文数据手册的中文翻译，其目的是协助用户阅读，该译文无法自动跟随原稿更新，同时也可能存在翻译上的不当。建议读者以英文原稿为参考以便获得更精准的信息。
- 3.本站提供的产品资料，来自厂商的技术支持或者使用者的心得体会等，其内容可能存在描述上的差异，建议读者做出适当判断。
- 4.如需与我们联系，请发邮件到marketing@iczoom.com，主题请标有“数据手册”字样。

Read Statement

1. The datasheets and other product information on the site are all from network reference or other public materials, and the copyright belongs to the original author and original published source. If readers and copyright owners have any objections, please contact us and we will deal with it in a timely manner.
2. The Chinese datasheets provided on the website is a Chinese translation of the English datasheets. Its purpose is for reader's learning exchange only and do not involve commercial purposes. The translation cannot be automatically updated with the original manuscript, and there may also be improper translations. Readers are advised to use the English manuscript as a reference for more accurate information.
3. All product information provided on the website refer to solutions from manufacturers' technical support or users the contents may have differences in description, and readers are advised to take the original article as the standard.
4. If you have any questions, please contact us at marketing@iczoom.com and mark the subject with "Datasheets" .

Series M

● Type 11M

Dimensions in mm (not to scale)

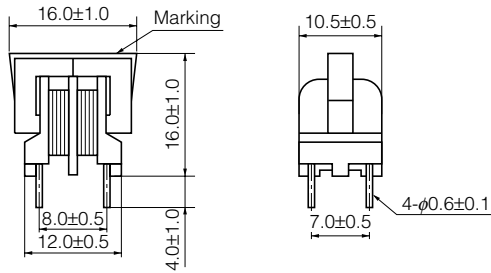

Recommended PWB piercing plan

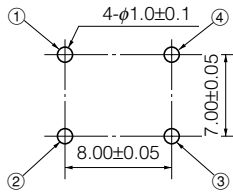

● Type 14M

Dimensions in mm (not to scale)

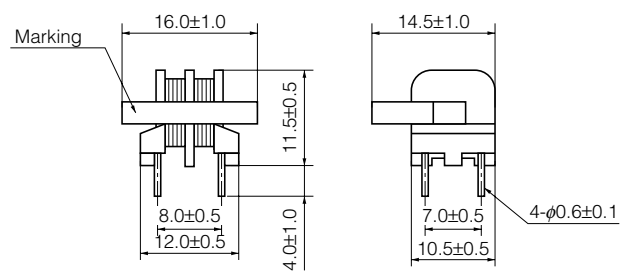

Recommended PWB piercing plan

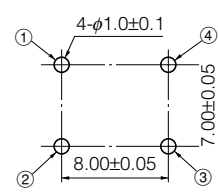

● Standard Parts (Vertical type)

Part No.	Marking	Inductance (mH) min.	*R _{bc} (Ω) [at 20 °C] (Tol ±20 %)	Current (A rms) max.
ELF11M010E	010E	30.0	9.70	0.1
ELF11M020E	020E	12.0	4.30	0.2
ELF11M030E	030E	6.0	2.30	0.3
ELF11M040E	040E	3.5	1.35	0.4
ELF11M050E	050E	2.5	0.93	0.5
ELF11M060E	060E	1.5	0.58	0.6
ELF11M070E	070E	1.0	0.36	0.7
ELF11M080E	080E	0.8	0.33	0.8
ELF11M090E	090E	0.7	0.28	0.9
ELF11M100E	100E	0.5	0.25	1.0

● Standard Parts (Horizontal type)

Part No.	Marking	Inductance (mH) min.	*R _{bc} (Ω) [at 20 °C] (Tol ±20 %)	Current (A rms) max.
ELF14M010E	010E	30.0	9.70	0.1
ELF14M020E	020E	12.0	4.30	0.2
ELF14M030E	030E	6.0	2.30	0.3
ELF14M040E	040E	3.5	1.35	0.4
ELF14M050E	050E	2.5	0.93	0.5
ELF14M060E	060E	1.5	0.58	0.6
ELF14M070E	070E	1.0	0.36	0.7
ELF14M080E	080E	0.8	0.33	0.8
ELF14M090E	090E	0.7	0.28	0.9
ELF14M100E	100E	0.5	0.25	1.0

* DC Resistance

● Type 16M

Dimensions in mm (not to scale)

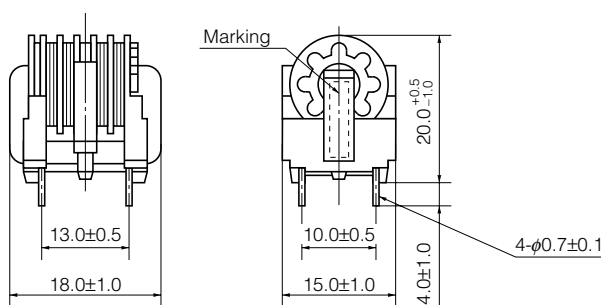

Recommended PWB piercing plan

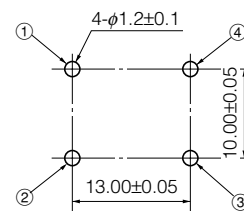

● Standard Parts

Part No.	Marking	Inductance (mH) min.	*R _{bc} (Ω) [at 20 °C] (Tol ±20 %)	Current (A rms) max.	Part No.	Marking	Inductance (mH) min.	*R _{bc} (Ω) [at 20 °C] (Tol ±20 %)	Current (A rms) max.
ELF16M020A	020A	28.0	3.650	0.2	ELF16M080A	080A	3.5	0.400	0.8
ELF16M030A	030A	20.0	2.700	0.3	ELF16M100A	100A	2.0	0.270	1.0
ELF16M040A	040A	15.0	1.800	0.4	ELF16M130A	130A	1.0	0.160	1.3
ELF16M050A	050A	8.0	0.980	0.5	ELF16M150A	150A	0.8	0.110	1.5
ELF16M060A	060A	7.0	0.800	0.6	ELF16M170A	170A	0.6	0.078	1.7
ELF16M070A	070A	5.0	0.550	0.7	ELF16M200A	200A	0.5	0.070	2.0

* DC Resistance

Design and specifications are each subject to change without notice. Ask factory for the current technical specifications before purchase and/or use. Should a safety concern arise regarding this product, please be sure to contact us immediately.